

# COOLEX

## Fan Coil Series High Static 800-2000 cfm



For more technical information please visit [www.coolex.com.kw](http://www.coolex.com.kw)



## Table of Contents

<b>INTRODUCTION</b>	<b>2</b>
<b>NOMENCLATURE</b>	<b>2</b>
<b>STANDARD SPECIFICATIONS</b>	<b>3</b>
<b>OUT STANDING FEATURES</b>	<b>4</b>
<b>OPTIONAL SPECIFICATIONS</b>	<b>5</b>
<b>GENERAL DATA</b>	<b>6</b>
<b>SELECTION PROCEDURE</b>	<b>7</b>
<b>SUPPLY AIR PERFORMANCE</b>	<b>8</b>
<b>PERFORMANCE DATA TABLES</b>	<b>9</b>
<b>UNIT DIMENSIONS</b>	<b>11</b>
<b>WIRING DIAGRAMS</b>	<b>12</b>
<b>NOTES</b>	<b>13</b>
<b>CONTACT DETAILS</b>	<b>16</b>

## OTHER COOLEX PRODUCTS

- 1. Air Cooled Screw Water Chillers**
- 2. Air Cooled Package Units**
- 3. Air Handling Units**
- 4. Ducted Split Units**
- 5. Concealed Ducted Split**
- 6. Air Cooled Scroll Water Chillers**

## INTRODUCTION

COOLEX High Efficiency High Static Fan Coil Units are highly efficient means of turning a water chiller, or hot water boiler into an efficient quiet air conditioning system with high performance, low power

consumption, easy installation "and low noise operation for both commercial and residential applications."

## NOMENCLATURE

**FCH 08 A D A G 0 0 0 A A**

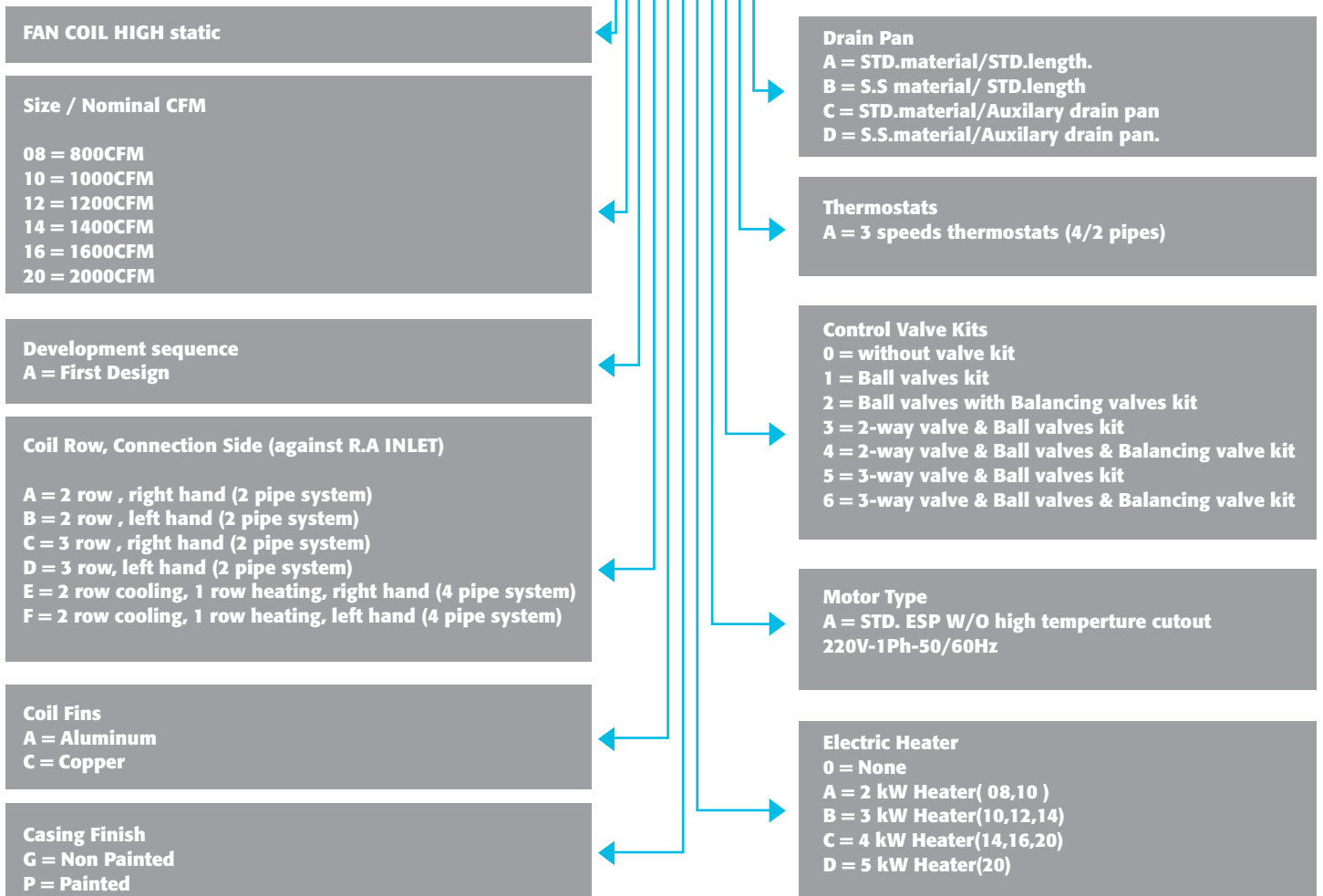

## STANDARD SPECIFICATIONS

### General

Fan coil units are provided with the latest advanced technology to provide quiet, reliable performance. Chilled water coils are designed to give optimum heat transfer efficiency. Units casings designed to provide easy accessibility for Chilled water coil and unit fan deck.

### Unit Construction

Fan Coil unit consists of a coil, motor/blower assembly and a drain pan securely mounted on heavy gauge galvanized steel housing.

### Evaporator Coils

High heat transfer efficiency coils are built up of ripple finned seamless copper tubes and mechanically bonded to scientifically design louvered fins.

The assembled coils are factory leak tested under water at a pressure of 350 psig for quality and leak free units.

### Blower Assembly

The units are provided with new designed low speed and Wide impellers centrifugal fan which are statically and dynamically balanced, designed for low sound level operation

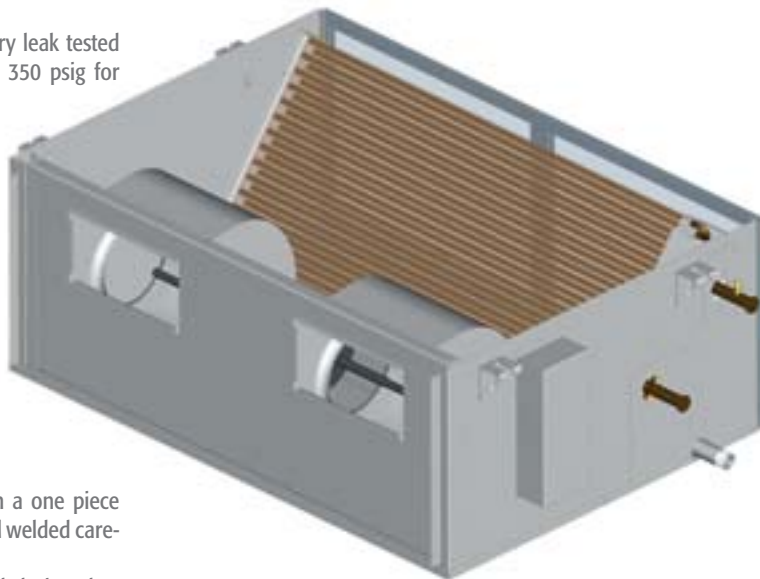

### Drain Pan

Drain Pan is constructed from a one piece painted galvanized sheet metal welded carefully to protect from leakage.

The insulation shall be special designed to be perfect

### Blower Motor

Motors are of permanent split capacitor type of maximum efficiency and minimum noise with permanently lubricated, sealed sleeve bearings.

Smart construction design and insulation with good noise elimination effect make the unit most lowest noise level.

## OUTSTANDING FEATURES

- Compact design
- Low profile
- Low sound power level
- For ducted & Ducts free applications
- 3 speed motors
- Easy maintenance
- Easy installation
- External terminal box

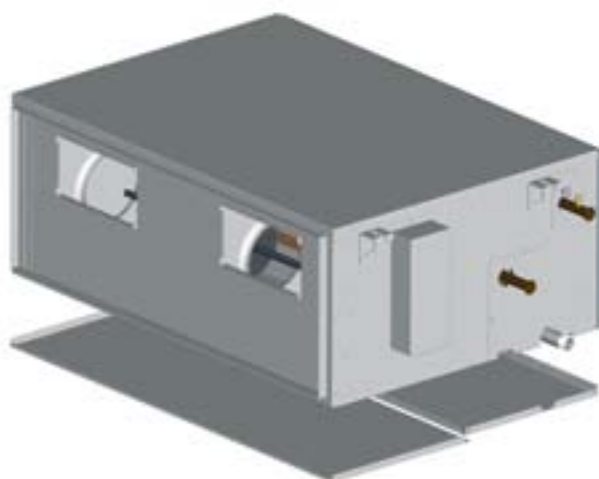

Bottom access for easy maintenance

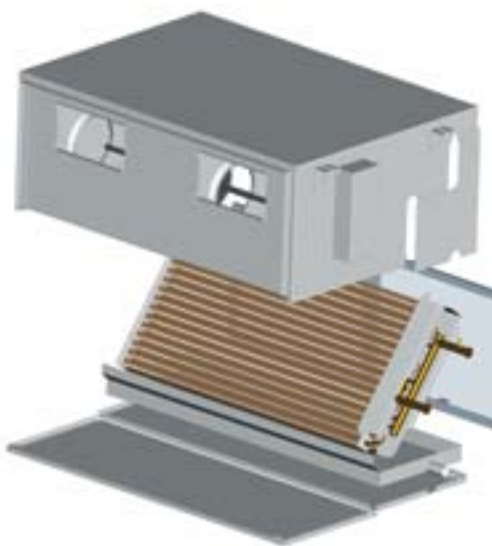

Bottom Coil and drain pan removal

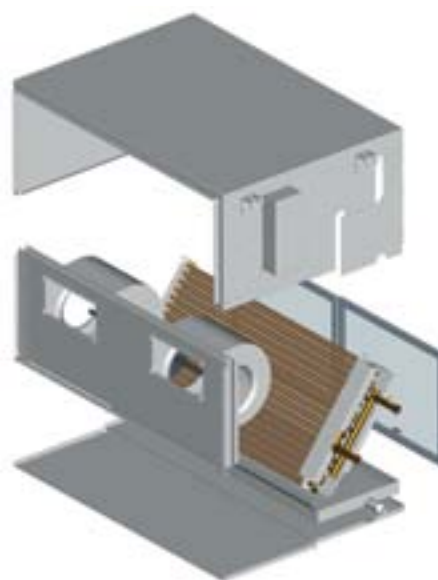

Bottom fan deck removal

## OPTIONAL SPECIFICATIONS

### Electric Heater

Finned Type Electric heater Following capacity range

kW	Model
2	FCH-8,10
3	FCH-10,12,14
4	FCH-14,16,20
5	FCH-20

### Cooling Coil

- Available with 2 or 4 pipe arrangements for cooling & heating.
- With 3/4" connections Left or Right hand for more installation flexibility
- Copper fins

### Air Filters

- Nylon filter
- Washable Aluminum filter 1/2"

### Casing

- Available with painted finishing

### Thermostats

- Decorative wall mounted type Operating mode: cooling or heating Controlling valve packages & Electric heater

### Control Valves

6 Kits of valves packages available for models flow control as per illustrated diagrams

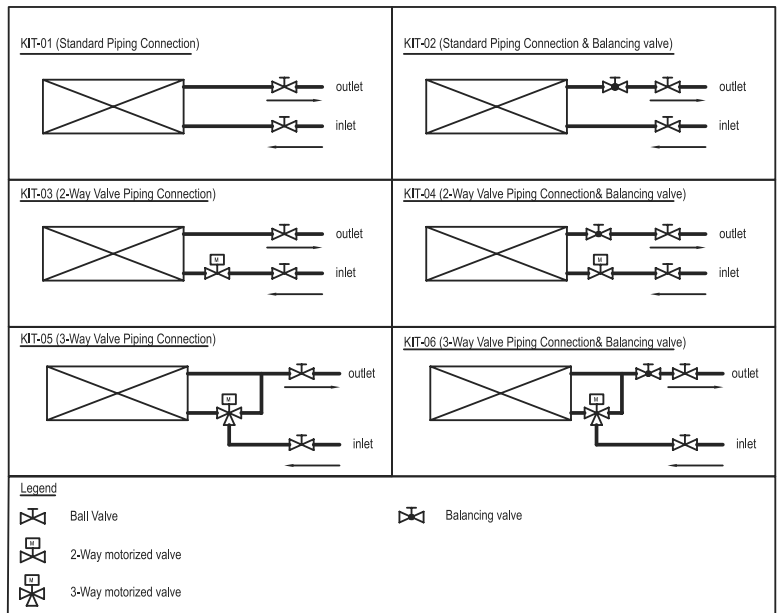

## OPTIONAL SPECIFICATIONS

### Thermostats

Micro-processor controlled thermostat with intelligent control algorithm (PID) Consequently, apart from the display of the room applications.

Temperature, the control quality is greatly enhanced in all applications



## GENERAL DATA

Model		FCH-08	FCH-10	FCH-12	FCH-14	FCH-16	FCH-20
CFM	High speed	900	1000	1200	1400	1600	2000
	Medium Speed	750	900	1100	1260	1450	1820
	Low Speed	725	800	1000	1150	1325	1640
COILS	Face Area, ft²	2.71	2.71	3.16	3.16	3.67	4.41
	Connections, Sweat Type	3/4"					
	Air Vent	Manual and Furnished on All Coils					
	Fin Material	Hydrophilic Aluminum					
	Fin Spacing, FPI	12					
	Tube Material	Copper					
	Test Pressure	350 psig					
	Maximum Working Pressure	200 psig					
FANS	Diameter, mm	160	180	200			
	Width, mm	200	200	190			
	Number Per Unit	2					
	Type	Double Width Double Inlet Forward Curved Directly Driven					
	Construction	Galvanized Steel - Dynamically Balanced					
	Housing	Galvanized Steel					
MOTORS	Watt (hp)	249 (1/3)	373 (1/2)		560 (3/4)		
	Quantity	1					
Unit Operating Weight, kg		39	39	54	54	58	61

## SELECTION PROCEDURE

The below example illustrates the selection procedure to assist using this catalog to select the appropriate FCH unit that meets the design requirements.

### Example :

#### Design requirements

- Total cooling capacity 29 [MBH]
- Sensible cooling capacity 19 [MBH]
- Air flow rate 950 [CFM]
- Entering Air temperature DB/WB 80/67 [°F/°F]
- Entering Water temperature 44 [°F]
- External static pressure 0.2 [in.wg]
- Altitude 2000 [ft]
- Power supply 220V-1Ph-50Hz

Altitude [ft]	Correction factor
Sea level	1
1000	0.996
2000	0.990
3000	0.984
4000	0.980
5000	0.974
6000	0.965
7000	0.960

From the performance Table:

\*Using the correction factor table at the specified altitude, thereby the required capacity will be:

**Corrected capacity** = Required capacity /corr. factor

**Corrected total capacity** = 29000 (Btu/hr)/.99  
= 29293 (Btu/hr)

**Corrected sensible capacity** = 19000 (Btu/hr)/.99  
= 19192 (Btu/hr)

From supply air performance (page 8) & the cooling capacity data (page 9) the closest selection model to the required Capacity is FCH-08

**Total capacity** = 30993 [Btu/hr]

**Sensible capacity** = 21300 [Btu/hr]



## SUPPLY AIR PERFORMANCE

Model	Speed	EXTERNAL STATIC PRESSURE (inch W.G)										
		0.00	0.05	0.10	0.15	0.20	0.25	0.30	0.35	0.40	0.45	0.50
		Air Flow Rate (CFM)										
FCH-08	HIGH	1122	1084	1039	1011	962	925	880	813	739	695	630
	MED	1065	1030	991	955	916	873	827	763	717	653	-
	LOW	986	950	915	878	833	791	742	686	625	575	-
FCH-10	HIGH	1178	1138	1091	1062	1010	971	924	854	776	730	662
	MED	1108	1071	1031	993	953	908	860	794	746	679	-
	LOW	1016	979	942	904	858	815	764	707	644	592	-
FCH-12	HIGH	1422	1379	1336	1289	1242	1189	1141	1089	1029	963	890
	MED	1366	1322	1282	1233	1190	1195	1091	1035	981	904	-
	LOW	1303	1261	1223	1173	1126	1075	1026	973	914	832	-
FCH-14	HIGH	1479	1434	1389	1341	1292	1237	1187	1133	1070	1002	910
	MED	1407	1362	1320	1270	1226	1231	1124	1066	1010	931	-
	LOW	1329	1286	1247	1196	1149	1097	1047	992	932	849	-
FCH-16	HIGH	1857	1822	1777	1730	1695	1652	1593	1520	1416	1312	1210
	MED	1809	1768	1722	1682	1635	1590	1526	1447	1350	1253	-
	LOW	1745	1696	1650	1621	1580	1536	1448	1397	1324	1251	-
FCH-20	HIGH	2173	2124	2082	2037	1991	1942	1894	1842	1785	1748	1681
	MED	2085	2029	2002	1960	1910	1861	1816	1761	1725	1672	1613
	LOW	2002	1965	1912	1875	1827	1775	1730	1682	1637	1596	1522

- Notes:
1. CFM values are for Dry Coil conditions. Wet coils is 92% of Dry Coil CFM. Wet coil conditions occur when SH/TH ratio is 0.91 or less.
  2. The above values include 3 Rows Cooling coil, & Nylon Air Filter.
  3. For ESP other than listed in the above tables, contact manufacturer's representative.

## PERFORMANCE DATA TABLES

### 2 Rows cooling coil

MODEL	Speed	0 ESP						0.2 ESP						0.4 ESP					
		Total Capacity		Sensible Capacity		gpm	WPD (Ft H <sub>2</sub> O)	Total Capacity		Sensible Capacity		gpm	WPD (Ft H <sub>2</sub> O)	Total Capacity		Sensible Capacity		gpm	WPD (Ft H <sub>2</sub> O)
		Btu/hr	T.R	Btu/hr	T.R			Btu/hr	T.R	Btu/hr	T.R			Btu/hr	T.R	Btu/hr	T.R		
08	HI	25974	2.16	18853	1.57	5.19	10.95	23732	1.98	17054	1.42	4.75	9.34	20172	1.68	14259	1.19	4.03	7.01
	MED	25115	2.09	18171	1.51	5.02	10.31	22966	1.91	16458	1.37	4.59	8.82	19744	1.65	13935	1.16	3.95	6.75
	LOW	23877	1.99	17197	1.43	4.78	9.43	21529	1.79	15345	1.28	4.31	7.86	17877	1.49	12533	1.04	3.58	5.67
10	HI	26708	2.23	19448	1.62	5.34	11.50	24429	2.04	17610	1.47	4.89	9.83	20804	1.73	14750	1.23	4.16	7.40
	MED	25684	2.14	18631	1.55	5.14	10.67	23507	1.96	16888	1.41	4.70	9.19	20236	1.69	14317	1.19	4.05	7.05
	LOW	24276	2.02	17519	1.46	4.86	9.67	21897	1.82	15639	1.30	4.38	8.12	18210	1.52	12790	1.07	3.64	5.85
12	HI	33052	2.75	23975	2.00	6.61	19.65	30581	2.55	21982	1.83	6.12	17.12	27329	2.28	19406	1.62	5.47	14.06
	MED	32230	2.69	23319	1.94	6.45	18.79	29739	2.48	21322	1.78	5.95	16.29	26452	2.20	18733	1.56	5.29	13.27
	LOW	31272	2.61	22561	1.88	6.25	17.82	28673	2.39	20491	1.71	5.73	15.27	25187	2.10	17770	1.48	5.04	12.19
14	HI	33792	2.82	24577	2.05	6.76	20.43	31292	2.61	22552	1.88	6.26	17.85	27986	2.33	19922	1.66	5.60	14.67
	MED	32759	2.73	23750	1.98	6.55	19.37	30295	2.52	21767	1.81	6.06	16.85	26912	2.24	19096	1.59	5.38	13.69
	LOW	31595	2.63	22825	1.90	6.32	18.18	28986	2.42	20744	1.73	5.80	15.59	25464	2.12	17990	1.50	5.09	12.42
16	HI	40235	3.35	29501	2.46	8.05	17.00	38245	3.19	27869	2.32	7.65	15.55	34494	2.87	24838	2.07	6.90	12.97
	MED	39594	3.30	28981	2.42	7.92	16.08	37388	3.12	27182	2.27	7.48	14.97	33429	2.79	24003	2.00	6.69	12.27
	LOW	38720	3.23	28276	2.36	7.74	15.82	36586	3.05	26542	2.21	7.32	14.38	33002	2.75	23669	1.97	6.60	12.00
20	HI	47767	3.98	34947	2.91	9.55	17.74	45485	3.79	33082	2.76	9.10	15.36	42727	3.56	30581	2.55	8.55	13.76
	MED	46561	3.88	33974	2.83	9.31	16.97	44306	3.69	32141	2.68	8.86	14.66	41790	3.48	29848	2.49	8.36	14.14
	LOW	45394	3.78	33035	2.75	9.08	16.23	43066	3.59	31155	2.60	8.61	14.02	40381	3.37	28751	2.40	8.08	13.30

### 3 Rows cooling coil

MODEL	Speed	0 ESP						0.2 ESP						0.4 ESP					
		Total Capacity		Sensible Capacity		gpm	WPD (Ft H <sub>2</sub> O)	Total Capacity		Sensible Capacity		gpm	WPD (Ft H <sub>2</sub> O)	Total Capacity		Sensible Capacity		gpm	WPD (Ft H <sub>2</sub> O)
		Btu/hr	T.R	Btu/hr	T.R			Btu/hr	T.R	Btu/hr	T.R			Btu/hr	T.R	Btu/hr	T.R		
08	HI	34271	2.86	23770	1.98	6.85	8.74	30993	2.58	21300	1.78	6.20	7.32	25862	2.16	17518	1.46	5.17	5.32
	MED	33137	2.76	22910	1.91	6.63	8.23	29993	2.50	20555	1.71	6.00	6.91	25313	2.11	17120	1.43	5.06	5.12
	LOW	31504	2.63	21682	1.81	6.30	7.53	28116	2.34	19166	1.60	5.62	6.16	22920	1.91	15398	1.28	4.58	4.30
10	HI	35351	2.95	24594	2.05	7.07	9.28	32008	2.67	22060	1.84	6.40	7.74	26766	2.23	18177	1.51	5.35	5.65
	MED	33996	2.83	23561	1.96	6.80	8.61	30800	2.57	21156	1.76	6.16	7.24	26035	2.17	17644	1.47	5.21	5.38
	LOW	32132	2.68	22154	1.85	6.43	7.80	28691	2.39	19591	1.63	5.74	6.39	23429	1.95	15762	1.31	4.69	4.47
12	HI	42133	3.51	29375	2.45	8.43	9.58	38649	3.22	26721	2.23	7.73	8.23	34109	2.84	23326	1.94	6.82	6.60
	MED	41085	3.42	28571	2.38	8.22	9.16	37585	3.13	25919	2.16	7.52	7.83	33014	2.75	22517	1.88	6.60	6.23
	LOW	39864	3.32	27642	2.30	7.97	8.69	36237	3.02	24909	2.08	7.25	7.34	31436	2.62	21359	1.78	6.29	5.72
14	HI	43181	3.60	30181	2.52	8.64	9.99	39649	3.30	27478	2.29	7.93	8.61	35022	2.92	24002	2.00	7.00	6.92
	MED	41861	3.49	29165	2.43	8.37	9.47	38386	3.20	26522	2.21	7.68	8.13	33678	2.81	23007	1.92	6.74	6.46
	LOW	40373	3.36	28029	2.34	8.07	8.89	36727	3.06	25275	2.11	7.35	7.52	31866	2.66	21674	1.81	6.37	5.86
16	HI	54633	4.55	38136	3.18	10.93	17.32	51630	4.30	35827	2.99	10.33	15.68	46019	3.83	31578	2.63	9.20	12.80
	MED	53762	4.48	37464	3.12	10.75	16.38	50473	4.21	34944	2.91	10.09	15.10	44598	3.72	30517	2.54	8.92	12.11
	LOW	52576	4.38	36552	3.05	10.52	16.12	49390	4.12	34121	2.84	9.88	14.50	44028	3.67	30092	2.51	8.81	11.84
20	HI	63678	5.31	44480	3.71	12.74	13.60	60304	5.03	41887	3.49	12.06	12.36	56248	4.69	38805	3.23	11.25	10.24
	MED	62070	5.17	43241	3.60	12.41	13.01	58741	4.90	40695	3.39	11.75	11.80	55014	4.58	37875	3.16	11.00	10.52
	LOW	60514	5.04	42047	3.50	12.10	12.44	57097	4.76	39447	3.29	11.42	11.28	53159	4.43	36483	3.04	10.63	9.90

Note: Data is based on 80/67°F (26.7/19.4°C) air on-coil DBT/WBT and 44/54 °F (6.7/12.2°C) entering/leaving water temperature

## PERFORMANCE DATA TABLES

### 1 Rows Heating coil

MODEL	Speed	0 ESP			0.2 ESP			0.4 ESP		
		Total Capacity	gpm	WPD (Ft H <sub>2</sub> O)	Total Capacity	gpm	WPD (Ft H <sub>2</sub> O)	Total Capacity	gpm	WPD (Ft H <sub>2</sub> O)
		Btu/hr			Btu/hr			Btu/hr		
08	HI	44456	4.45	6.86	40616	4.06	5.80	34322	3.43	4.31
	MED	43279	4.33	6.84	39541	3.95	5.78	33413	3.34	4.30
	LOW	41249	4.12	5.96	37686	3.77	5.04	31846	3.18	3.74
10	HI	46026	4.60	7.23	41846	4.18	6.11	35397	3.54	4.55
	MED	44323	4.43	6.76	40298	4.03	5.71	34087	3.41	4.25
	LOW	42001	4.20	6.15	38187	3.82	5.20	32302	3.23	3.87
12	HI	55312	5.53	11.76	50885	5.09	10.16	45205	4.52	8.25
	MED	53967	5.40	11.27	49648	4.96	9.74	44106	4.41	7.91
	LOW	52420	5.24	10.71	48224	4.82	9.25	42841	4.28	7.51
14	HI	56653	5.67	12.27	52146	5.21	10.61	46340	4.63	8.62
	MED	54954	5.50	11.63	50582	5.06	10.06	44950	4.50	8.17
	LOW	53063	5.31	10.94	48842	4.88	9.46	43404	4.34	7.69
16	HI	68426	6.84	8.71	64754	6.48	7.90	57972	5.80	6.51
	MED	67356	6.74	8.47	63741	6.37	7.68	57065	5.71	6.33
	LOW	65906	6.59	8.15	62369	6.24	7.39	55837	5.58	6.09
20	HI	80673	8.07	7.52	76508	7.65	6.85	71547	7.15	6.09
	MED	78683	7.87	7.20	74621	7.46	6.56	69782	6.98	5.83
	LOW	76765	7.68	6.89	72802	7.28	6.28	68081	6.81	5.58

*Note: Data is based on 70°F (21°C) air on-coil DBT and 180/160°F (82/71°C) entering/leaving water temperature*

## UNIT DIMENSIONS

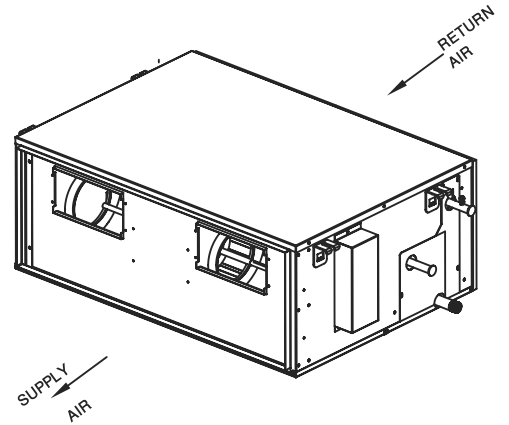
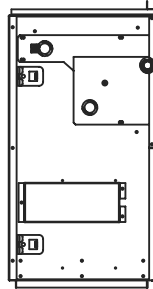
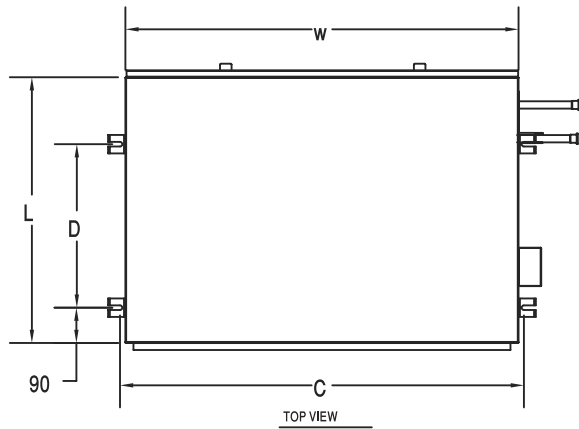
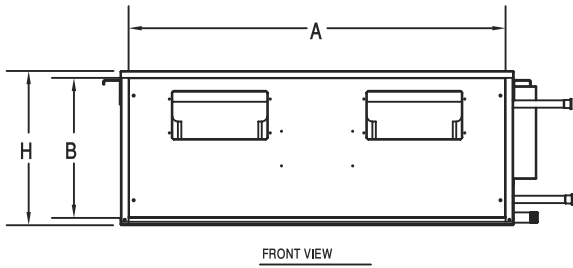

MODEL	DIMENSIONS					
	L	W	H	DUCT CONN. A X B	C	D
FCH-08	600	950	325	912 X 288	980	380
FCH-10	600	950	325	912 X 288	980	380
FCH-12	670	950	370	912 X 333	980	425
FCH-14	670	950	370	912 X 333	980	425
FCH-16	690	1020	400	980 X 363	1050	425
FCH-20	840	1020	400	980 X 363	1050	600

ALL DIMENSIONS ARE IN mm

## WIRING DIAGRAM

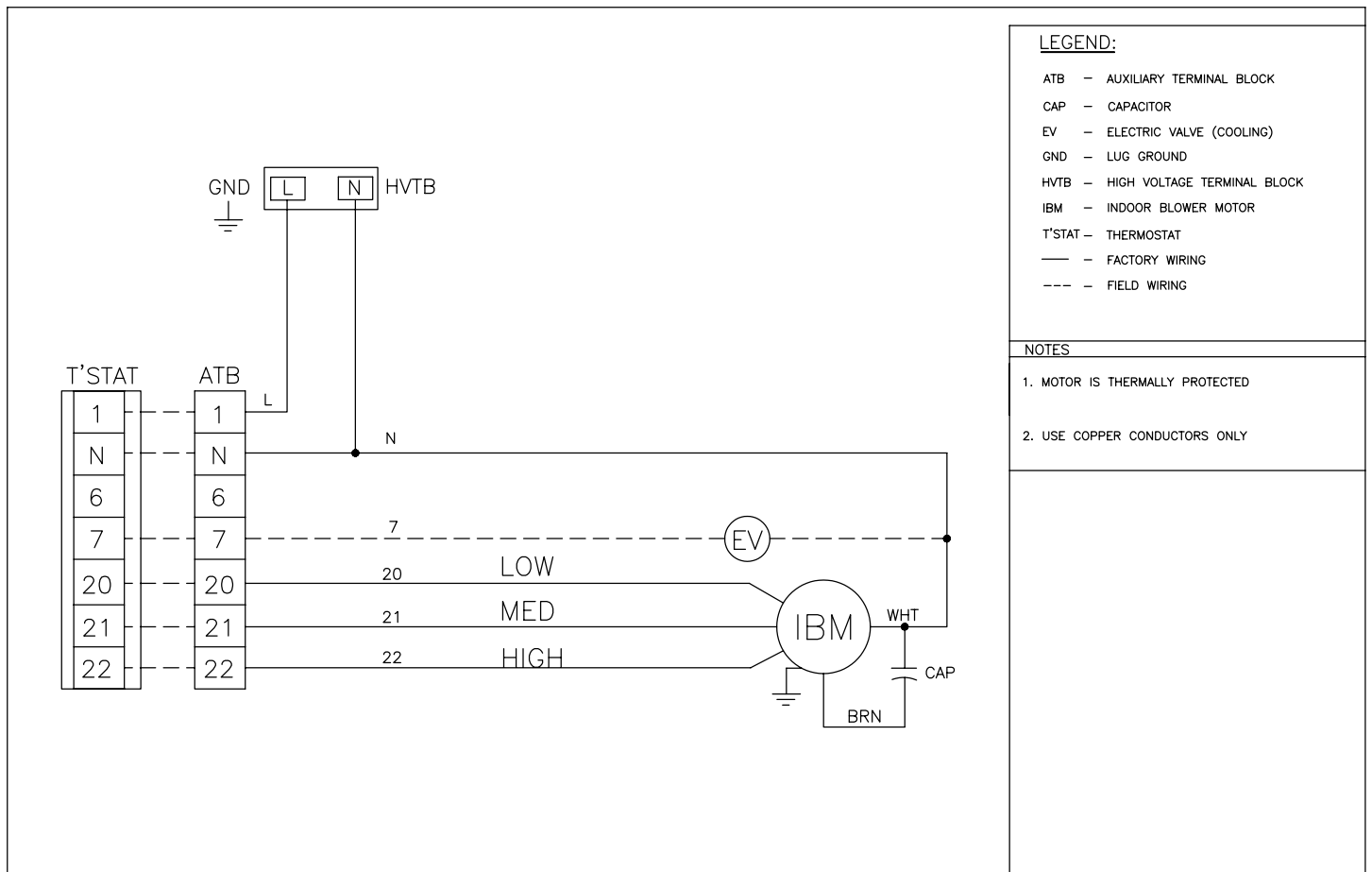

## About RIC

Refrigeration Industries Company (KSE 504) is a group holding company with diversified interests in manufacturing, contracting and services. Recognized regionally for our engineering capabilities and management excellence, RIC and its subsidiaries offer a wide range of high quality products and services that cater to both residential and commercial customers, in the areas of climate control technologies and specialized storage solutions.

In view of the growing Kuwait infrastructure and the limitations imposed on it by the country's arid climate, the Refrigeration Industries Company was established 40 years ago in 1973, by Amiri Decree. The company's operations began with the construction of the first cold stores in the region, to enable the storage of the imported foods, on which Kuwait relied. Along with the development and advancement of the country, so has RIC prospered and expanded, and is now a milestone in the history of modern Kuwait.

RIC takes pride in its successful record and the many accolades it has garnered over time, but the greatest achievement has been the provision of comfort and protection from the harsh climate, to the people of Kuwait.

More than 40 years of uninterrupted service, overcoming extreme weather conditions, war, economic recessions and ever increasing competition, is testimony to the fact that RIC has met the expectations and responsibilities that was envisioned at the beginning and also highlights the tenacity and vision to exceed them in the future.

## Facts throughout the years

- 1973 Warehouses were established by Amiri Decree.
- 1979 RIC Constructed the Medical Cold Stores Complex, the world's largest at that time.
- 1980 RIC Air Conditioning manufacturing plant set up in Sulaihya.
- 1981 Production of Package & Mini-Split A/Cs started under York-Gulf.
- 1984 RIC was listed in Kuwait Stock Exchange.
- 1986 COOLEX brand Production Launched.
- 1991 RIC rebuilt the manufacturing plant destroyed during the war.
- 1997 Achieved ISO Certification ISO 9001:1994.
- 2002 ETL Designed testing lab became fully operational.
- 2004 Privatization of RIC.
- 2010 COOLEX becomes the first A/C Unit to Pass MEW's new regulations.
- 2010 RIC Factory Renovation and Expansion into neighboring countries.
- 2012 Achieved UL & AHRI Certification for Coolex Units.
- 2014 Achieved SASO Certification for Concealed Ducted Split Series.
- 2014 Achieved EUROVENT Certification for Air Handling Units AHU.
- 2014 Achieved UL Certification for Air Cooled Chillers.

## نبذة عن الشركة

شركة صناعات التبريد (متداولة في سوق الكويت للأوراق المالية برقم 504) هي شركة متنوعة الأنشطة تعمل في مجال التصنيع والمقاولات والخدمات. ونحن نقدم مجموعة كبيرة من المنتجات والخدمات والحلول التقنية في مجال مواجهة الظروف المناخية وحلول التخزين. وقد حازت الشركة على إعراف إقليمي بقدراتها الهندسية وكفاءتها الإدارية.

شركة صناعات التبريد هي مجموعة شركات تهدف إلى توفير أعلى مستويات الجودة من حيث المنتجات والخدمات التي تلبي احتياجات عملائها السكنية والتجارية. وعلى مدى أربعين عاماً مضت على إنشاء شركتنا فقد إستطعنا أن نوطد أقدامنا في جميع قطاعات السوق الكويتي. ونحن إذ نفتخر بالإنجازات التي حققناها، إلا أننا أشد فخراً بأننا تمكنا من الوقوف إلى جانب أهل الكويت على مدى سنوات طويلة في مواجهة تقلبات الظروف المناخية القاسية سواء من حيث درجات الحرارة العالية أو الأتربة أو الرطوبة.

وباعتبارها إحدى الشركات الصناعية العاملة في دولة الكويت، فقد واجهت الشركة تحديات وآمال كبيرة في سعيها لتحقيق النجاح، وقد كانت الشركة - ولا تزال - معلماً من المعالم المهمة في نظر أهل الكويت لما قدمته من منتجات وخدمات إستطاعت أن تغير الطبيعة القاسية لمناخ الكويت. فبعد نحو 40 عاماً تقريباً، لا يزال السؤال مطروحا حول تحقيقنا لهذه التوقعات، فهل إستطاعت الشركة أن تتحمل مسؤولياتها على الوجه الأكمل؟ ويأتي الرد بالإيجاب، فعلى مدى أربعين عاماً تقريباً لم تتوقف الشركة خلالها عن الإستمرار في تقديم خدماتها وأعمالها رغم الصعوبات التي تمثلت في ظروف الطقس القاسية أو الحروب أو الكساد الاقتصادي أو إرتفاع حدة المنافسة، فقد كانت كل واحدة من هذه الظروف بمثابة شهادة على أننا حققنا ما وعدنا به وما عقدنا العزم على تنفيذه.

## حقائق وتواريخ

- 1973 تم إنشاء المستودعات بناء على مرسوم أميري.
- 1979 عهدت وزارة الصحة الكويتية لشركة صناعات التبريد بإنشاء مجمع مستودعات مخازن التبريد العلبية، وقد كان هذا المجمع حينها هو الأضخم من نوعه على مستوى العالم، وقد وصلت تكلفته إلى 12,000,000 دينار كويتي.
- 1980 تم إنشاء مصنع مكيفات الهواء التابع لشركة صناعات التبريد في الصليبية.
- 1981 بدء إنتاج أجهزة التكييف المدمجة والمنفصلة الصغيرة تحت علامة York-Gulf.
- 1984 تم قيد شركة صناعات التبريد في سوق الكويت للأوراق المالية.
- 1986 بدء إنتاج مكيفات علامة كولكس.
- 1991 قامت شركة صناعات التبريد بإعادة بناء مصنعها الذي دمرته الحرب.
- 1997 الحصول على شهادة الأيزو 9001:1994.
- 2002 بدء تشغيل مختبر فحص وحدات التكييف (ETL).
- 2004 خصخصة شركة صناعات التبريد.
- 2010 كانت وحدات كولكس أول وحدات تكييف هواء تجتاز اللوائح التي أقرتها (وزارة الكهرباء والماء).
- 2010 تم تجديد مصنع شركة صناعات التبريد وبدء التوسع والتصدير إلى الدول المجاورة.
- 2012 الحصول على شهادة UL و AHRI لأجهزة التكييف كولكس.
- 2014 الحصول على شهادة SASO لأجهزة التكييف المنفصلة.
- 2014 الحصول على شهادة EUROVENT لأجهزة مناولة الهواء.
- 2014 الحصول على شهادة UL لمبردات الهواء الشيلر.

## NOTES

## Coollex Distributors

### United Arab Emirates UAE

#### Obaid Humaid Al-Tayer Engineering Division Al Tayer Group

Address: Dubai – UAE, PO Box 2623  
Tel : +971 4 2011272  
Fax : +971 4 2825008  
Mobile : +971 50 3500747  
Email : bkrishnan@altayer-eng.com  
Website : www.altayer.com

### Kingdom of Saudi Arabia KSA

#### Al-Etmad for Refrigeration and Air Conditioning Industries Company

Address: Al Qortobah Quartier, King Abdullah Road  
Riyadh – KSA, P.O. Box 50467 Riyadh 11533  
Tel : + 966 11 4958004  
Fax : + 966 11 4958812  
Mobile : + 966 920022181  
Email : abunaif722@ksacoollex.com  
Website : www.Coollex.co

### Republic of Iraq

#### SWEER Company Limited

Address: Al Senak -Jumhuria Street - Baghdad-Iraq  
P.O. Box: 8095  
Tel : +964 1 8181196  
Mobile : +964 7705 884444  
Email : sweerco@yahoo.com  
Website : www.sweerco.com

### State of Qatar

#### Darwish Trading Company W.L.L

Address: P.O.Box 92 Doha - Qatar  
Direct : +974 4468 3951  
Tel : +974 4468 3950  
Fax : +974 4468 5681  
Email : acvr@darwish-tdg.qa  
Email : dtcaircondi@darwish-tdg.qa  
Website : http://www.darwish-trading.com

### Sultanate of Oman

#### Al Noor Projects Engineering & Trading Company

Address: Third Floor, Oman House  
P.O. Box: 1047, P.C: 114 Hay Al Mina - Muscat  
Tel : +968 24709402/403  
Fax : +968 24709401  
Email : info@alnoorprojects.com  
Email : gm@alnoorprojects.com  
Website : www.alnoorprojects.com

### Kingdom of Bahrain

#### Y.K. Almoayyed & Sons

Address: EHAD – Project Department, Sehla Workshop  
P.O. Box 143, Manama, Kingdom of Bahrain  
Tel : +973 17 400 444, Extn. 205  
Direct : +973 17 405 250  
Fax : +973 17 400 388  
Email : Pradeep@almoayyed.com.bh  
Email : ac@almoayyedcg.com  
Website : www.almoayyed.com

### Turkey

#### CS GROUP

Address : Küçükyalı, Altıntepe Mah.  
Galipbey Cad. CS Plaza,  
No: 127 34840 Maltepe-Istanbul Turkey  
Tel : +90 216 388 85 50  
Fax : +90 216 388 86 90  
Call Center: +90 444 44 91  
Email : info@csgroup.com.tr  
Website : www.csgroup.com.tr

### Iran

#### Capital ICEBERG Limited Company

Address: No. 31, 3rd Floor, Aghdasieyh Trade Center  
Aghdasieyh Street. Tehran – Iran  
Tel : +98 (021) 26110510  
Fax : +98 (021) 26110510  
Mobile : +98 912 119 2961  
Email : info@capitaliceberg.com  
Email : saeed.s@capitaliceberg.com  
Email : sara.s@capitaliceberg.com  
Website : www.capitaliceberg.com

Please contact Sales and Marketing Department  
sales@ric.com.kw or www.coollex.com.kw for  
specific information on the current design and  
specifications. **Ref no.: CFH14-5-000**

**CENTRAL AIR CONDITIONING AND SPLIT UNIT**  
Coollex continuously works towards the improvement of  
its products. Hence, the design and specifications of the  
ordered product may vary without prior notice.



[www.coolex.com.kw](http://www.coolex.com.kw)

