

COOLEX

ACC Scroll Water Chiller R-407C

03 - 55 TR
11-193 kW



**RESIDENTIAL AND COMMERCIAL
AIR COOLED SCROLL WATER
CHILLER**

50 Hz

For more technical information please visit www.coolex.com.kw



Table of Contents

INTRODUCTION

NOMENCLATURE

OUT STANDING FEATURES

STANDARD SPECIFICATIONS

MICROPROCESSOR CONTROLLER

OPTIONAL SPECIFICATIONS

PHYSICAL DATA

UNITS ELECTRICAL DATA

CORRECTION FACTORS

CORRECTION CURVES

SELECTION PROCEDURE

WATER FLOW LIMIT AND COOLER WATER PRESSURE DROP CURVES

PERFORMANCE DATA TABLES - ENGLISH SYSTEM

PERFORMANCE DATA TABLES - METRIC SYSTEM

UNIT DIMENSIONS

TYPICAL WIRING DIAGRAM

MICROPROCESSOR OPERATION SEQUENCE

MICROPROCESSOR TROUBLESHOOTING

INSTULATION CLEARANCE

RIGGING INSTRUCTIONS

MOUNTING LOCATION AND DISTRIBUTION LOAD – ALUMINUM COIL MOUNTING

LOCATION AND DISTRIBUTION LOAD – COPPER COIL

OTHER COOLEX PRODUCTS

- 1. Air Handling Units**
- 2. Residential Packaged units**
- 3. Commercial packaged units**
- 4. Air Cooled Screw Water Chillers**
- 5. Ducted Split Units**
- 6. Concealed Split Units**
- 7. Fan Coil Units**

INTRODUCTION

COOLEX Air cooled scroll water chillers **ACC** series designed to be suitable for gulf harsh environment with optimum performance, high efficiency, low power consumption, easy installation and low noise operations.

ACC series chillers were designed to provide central cooling for Residential and commercial applications with the high reliability utilizing the R-407 c refrigerant. **ACC** series are available from 03 TR (11 KW) to 55TR (193 KW).

NOMENCLATURE

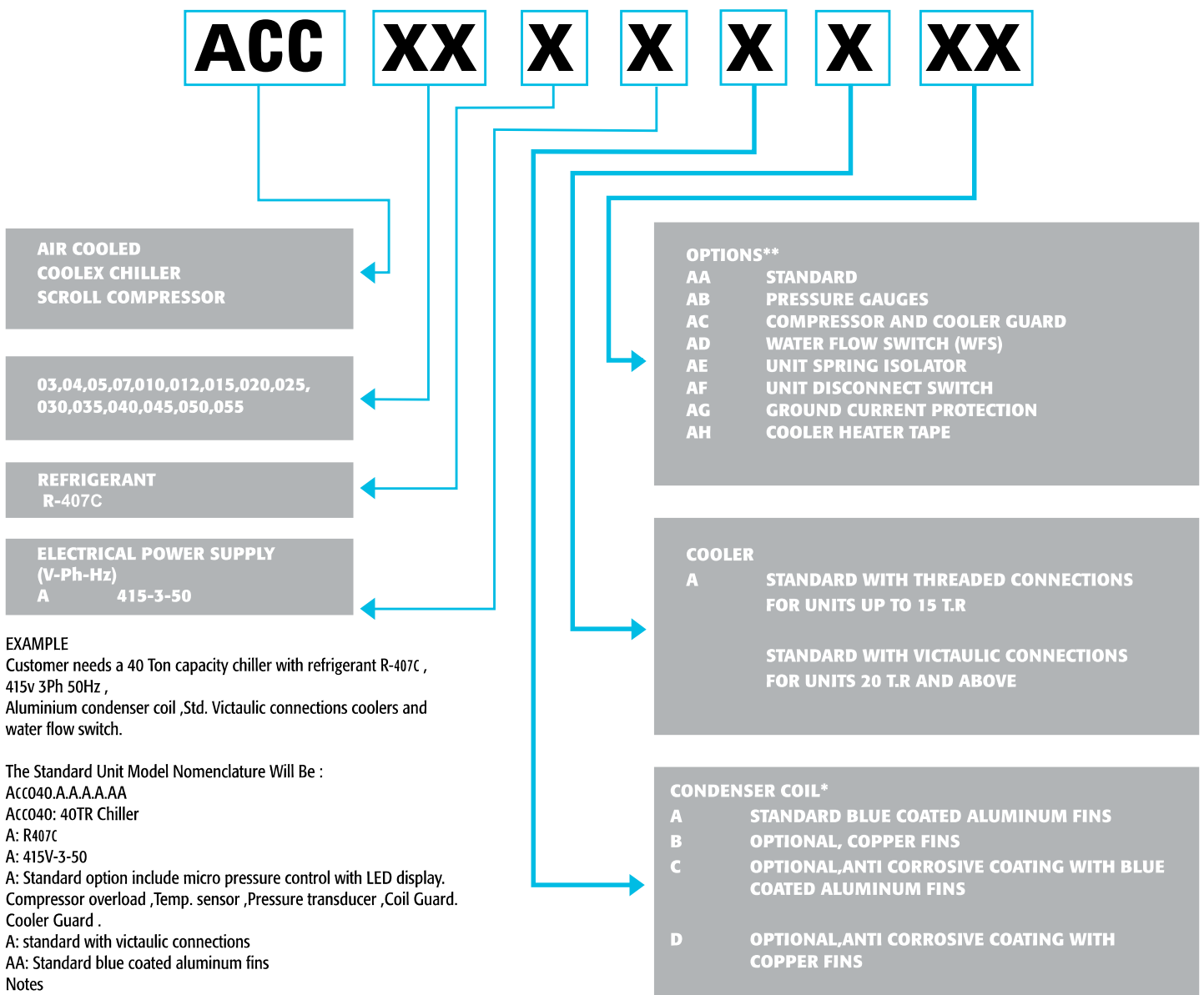

EXAMPLE
 Customer needs a 40 Ton capacity chiller with refrigerant R-407C , 415v 3Ph 50Hz , Aluminium condenser coil ,Std. Victaulic connections coolers and water flow switch.

The Standard Unit Model Nomenclature Will Be :
 ACC040.A.A.A.A.A
 ACC040: 40TR Chiller
 A: R407C
 A: 415V-3-50
 A: Standard option include micro pressure control with LED display, Compressor overload ,Temp. sensor ,Pressure transducer ,Coil Guard. Cooler Guard .
 A: standard with victaulic connections
 AA: Standard blue coated aluminum fins
 Notes

*For other coating specify your requirements in writing
 ** For othe combination , please consult factory

OUT STANDING FEATURES

- **Designed to conform to ASHRAE 15 1994 (Safety Code for Mechanical Refrigeration).**
- **Performance Data are rated in accordance to ARI standard 550/590 98.**
- **Painted panel Salt Spray test in accordance to ASTM B 117 Salt Spray (Fog) Testing.**
- **Steel sheet panels lock forming quality conforming to ASTM A 653 Commercial weight G 90.**
- **Control panel design is equivalent to NEMA 4 (IP55 Weather proof and dust free).**
- **Internal power Connection High Voltage & control wire cables identification & markers As per NEC standard**
- **Compressors and Fan motors circuit breakers are having thermal protection. Single point power connection.**
- **Complete wired control panel with advanced microprocessor controller Matching with Building Management System.**
- **High efficiency scroll compressors.**
- **Low noise aerodynamic design condenser fan, direct drive with rolled for venture design to eliminate short circuiting of airflow.**
- **All fans are propeller type with aerodynamic design, top discharge & provided with protective grill.**
- **All fan motors are Totally Enclosed Air over (TEAO) type with class "F" winding insulation , ball bearings & internal thermal protection of automatic reset.**
- **Thermostatic expansion valve as standard accessories.**
- **Easy service accessibility.**

STANDARD FEATURES

Scroll Compressor has proven to be the most reliable, most efficient and quietest compressor technology available today. Compressor exclusive design features both axial and radial compliance, which allows the compressor to be more tolerant of liquid refrigerant or debris. Compliant Scroll compressors perform at higher efficiency levels than reciprocating compressors, and last longer over time. Scroll compressors have 50% fewer moving parts, which increases reliability and reduces sound levels. They also operate without suction valves, for added reliability and ease of maintenance.



STANDARD FEATURES

BRAZED PLATE WATER COOLER (UNITS UP TO 16TR)

High efficiency brazed plate heat exchanger consists of thin corrugated stainless steel plates vacuum brazed together using copper as the brazing material. Although ideal for numerous applications. Plates are brazed at all contact points, ensuring optimal heat transfer efficiency and pressure resistance. The plates are designed to provide the longest possible lifetimes.



CONDENSERS COIL

The coils are built up seamless copper tubes and mechanically bonded to scientifically designed aluminum fins for maximum heat transfer efficiency. The assembled coils are factory leak tested under water at a pressure of 450 psig for quality and leak free unit. They also undergo dry chemical cleaning after Manufacturing for optimum system cleanness.



SHELL AND TUBE LIQUID COOLER (UNITS 20TR & ABOVE)

High efficiency DX shell & tube type cooler with removable "U" shape bundled tubes are made of internally grooved copper tubes expanded into heavy steel tubular sheets. The cooler shell, header, tube sheet, refrigerant and water connections are made of carbon steel. Baffles are made of brass. The coolers are insulated with heavy closed cellular foam insulation (3/4" thick) as a standard other thickness are available as an option. All chiller barrels are fitted with vent, drain connection and Victaulic water pipe connection as standard. (flange and ASME available as an option)



Coolers are tested and stamped for refrigerant/ water design /test pressure as follows:

COOLER	WATER SIDE	
	DESIGN PRESS.	TEST PRESS.
	BAR/PSIG	BAR/PSIG
STD	16/235	22.8/335
ASME	10/147	11.3/165

COOLER	REFRIGERANT SIDE	
	DESIGN PRESS.	TEST PRESS.
	BAR/PSIG	BAR/PSIG
STD	29/426	41.5/610
ASME	15.5/228	23.3/342

STANDARD FEATURES

CONDENSER FAN MOTOR

All condenser fan motors are totally enclosed air over type (TEAO) with class "F" winding insulation and ball bearings for high ambient application. The motors shall be three phase with internal thermal protection of automatic reset type.



UNIT CASING (CABINET)

The unit casing are perfectly designed to eliminate the corrosion problem usually associated with outdoor equipment. The casing sheet metal is fabricated from hot dipped heavy gauge (G90), zinc coating and zero spangle galvanized steel, oven-baked powder coated.

CONTROL PANEL

The control panel design is equivalent to NEMA 4 (IP55) with hinged door for easy access ensuring dust and weather proof construction. Internal power and control wiring is neatly routed, adequately anchored and all wires identified with cable markers as per NEC standards applicable to HVAC industry. The control voltage is 240V-1Ph-50Hz. The electrical controls used in the control panel are UL approved which are reliable in operation at high ambient conditions (Up to 70°C) for a long period.

CONSTRUCTION AND REFRIGERATION

- **INDEPENDENT REFRIGERATION CIRCUIT PER COMPRESSOR**
- **LIQUID LINE THERMAL EXPANSION VALVE**
Used to regulate the refrigerant flow to the water cooler and maintain a constant Superheat and load optimization.
- **LIQUID LINE FILTER DRIER**
Refrigerant circuits are kept free of harmful moisture, sludge, acids and oil contaminating particles by the filter drier.
- **LIQUID LINE MOISTURE INDICATOR SIGHT GLASS**
Installed in the liquid line. An easy to read color indicator shows moisture contents and provides a mean for checking the system refrigerant charge.
- **LIQUID LINE SOLENOID VALVE (OPTIONAL)**
Closes when the compressor is off to prevent any liquid refrigerant from accumulating in the water cooler during the off cycle.
- **LIQUID LINE SHUT OFF VALVE (OPTIONAL)**
- **FULLY CHARGED UNIT WITH REFRIGERANT**
- **DISCHARGE, SUCTION LIQUID LINE PIPES**
All hard copper pipes and minimize pipe brazed joints which in turn increases the system reliability.
- **COMPRESSOR/COOLER GUARD**
protects the compressor from vandalism
- **Blue-Coated Aluminum fins condenser coils**
for seashore or acid corrosive environments

STANDARD FEATURES

ELECTRICAL

- **COMPRESSOR IN-BUILT PROTECTION DEVICE**
- **STARTER.**
The starter is operated by the control circuit and provides power to the compressor motors. These devices are rated to handle safely both RLA and LRA of motors.
- **CRANKCASE HEATERS.**
Each compressor has crankcase heater. The compressor crankcase heater is always on when the compressors are de-energized. This protects the system against refrigerant Migration, oil dilution and potential compressor failure.
- **HIGH PRESSURE SWITCH**
This switch provides an additional safety protection in case of excessive discharge pressure.
- **UNIT ON-OFF SWITCH.**
On Off Switch is provided for manually switching the unit control circuit.
- **INDICATOR LIGHTS.**
LED lights indicates power ON to the units, MENU adjustment and FAULT indications due to trip on safety devices.
- **UNDER VOLTAGE AND PHASE PROTECTION.**
This feature protects the chiller against low incoming voltage as well as single phasing , phase reversal and phase imbalance by de-energizing the control circuit.
- **FAN MOTOR CIRCUIT BREAKER (STANDARD FOR UNITS ABOVE 25 TR)**
For each pair of condenser fan motor.
- **CONTROL CIRCUIT TRANSFORMER**
- **COMPRESSOR CIRCUIT BREAKERS.**
Protects compressor against overload and short circuit. When tripped, the breaker opens the power supply to the compressor and control circuit through auxiliary contacts. These circuit breakers are provided with thermal adjustable switch for precise over load setting.
- **EXTERNAL OVERLOAD RELAY FOR EACH COMPRESSOR**
- **CONTROL FUSED FOR SHORT CIRCUIT PROTECTION**

MICROPROCESSOR CONTROL

The advanced microprocessor controller is designed with the latest technology to give the best performance of the chiller and to ensure its efficiency and reliability.

It is not only monitoring the digital and analogue inputs but also responds very quickly to any problem before and during the operation of the chiller.

The user friendly display is a very effective tool for troubleshooting with its multi linked back illuminated LCD panel.

It shows all the required data of the chiller while it is running and keep all the faults in the alarm history.

The push buttons on the display board allows accessing to the operating conditions, control set points & alarm history.

The controller is capable to communicate with the building management system (BMS) open protocols like BacNet, LON, Modbus through optional gateway interfaces.

The microprocessor controller is especially designed to withstand the high ambient temperature; it can withstand more than 70 degree C without any ventilating or cooling.

The microprocessor controller consists of the following hardware:

1 Display Board:

Provided with simple push buttons (6 Nos) on the display board and menu driven software to access operating conditions, control set points and history that are clearly displayed on the LCD panel.

2 Master Board:

This controls up to four compressor system.

- Temperature control: The user can select the temperature control based on either leaving water temperature or returning water temperature. The software will control system using a Proportional Integral Derivative (PID) for precise control logic.
- Compressors hour equalization.
- Condenser Fan hour equalization
- Software update through PC programming or hardware key.
- Suction temperature sensor.

MICROPROCESSOR CONTROL

- Discharge pressure transducer.
- Head pressure control by fan cycling.
- Short cycling protection for compressors (time delay)
- Compressor locking option through parameter or digital input
- Pump management
- Free terminal for general alarm output.
- Sensor alarm management.
- Pump alarm management
- Power supply alarm
- Compressor circuit breaker trip alarm.
- Compressor winding temp/SSPS alarm.

System Protection / Alarms

- Low suction pressure.
- High discharge pressure (through pressure switch and transducer).
- Anti freeze protection.
- Flow switches alarm.

MICROPROCESSOR CONTROL

Data Display

In the normal operating mode the graphic LCD displays the system status, the inlet and outlet water temperatures, the set point, run time of the chiller, the alarm history. In addition, for each compressor:

- Discharge pressure.
- Compressor status
- Fan status
- Run time of each compressor.
- Alarm history with time stamp.
- The Leaving or Return water temperature is continuously displayed



OPTIONAL FEATURES

CONSTRUCTION AND REFRIGERATION

- **WATER FLOW SWITCH**
Paddle type field adjustable flow switch for water cooler circuits, Interlock into safety circuits so that the unit will remain off unit water flow is determine.
- **UNIT MOUNTING SPRING ISOLATORS**
This housed spring assemblies have a neoprene friction pad on the bottom to prevent vibration transmission.

OPTIONAL FEATURES

- **ASME CODE STAMPED**
For shell and tube liquid coolers
- **PRESSURE GAUGES:**
Suction & discharge pressure gauges
- **COATED COPPER/ALUMINUM FINS CONDENSER COILS**
For seashore or acid corrosive environments

ELECTRICAL

- **NON-FUSED MAIN DISCONNECT SWITCHES**
De-energize power supply during servicing/repair works as well as with door interlock.
- **COOLER HEATER TAPE**
Prevent freezing up of water on low ambient.
- **GROUND CURRENT PROTECTION**
Additional protection for compressor in the case of abnormal current leakage.
- **EXTERNAL OVER LOAD RELAY**
Overload relay can be provided for Condenser fan Motor
- **BUILDING MANAGEMENT SYSTEM (BMS)**
MODBUS, BACNET, and LON protocol

PHYSICAL DATA

UNIT MODEL (ACC)		03	04	05	07	010	012	015	020	025	030	035	040	045	050	055
COOLING CAPACITY *	TR	3.3	4.1	5.5	6.9	10.8	11.5	13.6	20.3	24.3	27.3	37.1	40.6	47.8	50.6	55.2
	kW	11.6	14.4	19.3	24.3	38	40.5	47.8	71.4	85.5	96.0	130.5	142.8	168.1	178.0	194.1
COMPRESSOR		Hermetic Scroll														
QUANTITY	(No.)	1	1	1	1	2	2	2	2	2	2	4	4	4	4	4
REFRIGERANT		R-407 C														
CONDENSER - Type		Enhanced Fins and Tubes														
Row /FPI		1/15	2/14	2/16	2/13	2/16	2/16	2/16	3/16	3/16	4/16	3/16	4/16	4/16	4/16	4/16
Total Area, Sq.ft		15.75	15.29	18.28	21.72	15.83	19.28	19.28	47	47	47	93	93	93	93	93
CONDENSER FAN		Propeller Direct Driven (Axial)														
QUANTITY	(No.)	1	1	1	2	2	2	2	2	2	2	4	4	4	4	4
AIR FLOW	(CFM)	3360	3605		6995	7210	18300		21000			40000				
COOLER		Direct Expansion Plate Heat Exchanger and Shell & Tube														
QUANTITY	(No.)	1	1	1	1	1	1	1	1	1	1	1	1	1	1	1
WATER CONNECTION SIZE (IN/OUT) DIAMETER	(in)	1-1/4"	1-1/4"	1-1/2"	2"	2"	2"	2"	2.5"	2.5"	2.5"	4"	4"	4"	4"	4"
EXPANSION DEVIC		Thermostatic														
GENERAL																
REFRIGERATION CIRCUITS	(No.)	1	1	1	1	2	2	2	2	2	2	4	4	4	4	4
REFRIGERANT CHARGE (Comp 1/comp 2)	(Kg)	2.4	3.2	4	5.6	8	9.6	12	16	20	24	28	32	36	40	44
SHIPPING WEIGHT -	(Kg)	131.5	144.5	185.4	230.0	265.6	577.9	583.9	979.4	984.0	1142.0	1779.0	1956.9	2152.6	2367.9	2604.7
OPERATING WEIGHT -	(Kg)	136.8	150.3	192.8	239.2	276.2	601.0	607.3	1018.6	1023.4	1187.7	1850.2	2035.2	2238.7	2462.6	2708.9

* Capacity Rating are Based on Standard ARI-550/590 Conditions Of 95°F (35°C) Ambient, 44°F (6.7°C) Leaving Chilled Water Temperature, 10°F (5.5°C) Range and 0.0001 ft².h²/Btu (0.018 m². C/kW) Fouling factor

* Specification are subject to change without prior notice

ELECTRICAL DATA

Model #	Supply Voltage: (415v-3ph-50hz)		Compressor Type-1			Compressor Type-2			Condenser fan motor				MCA	MOCP
	Min.	Max.	RLA (Ea)	LRA (Ea)	Qty	RLA (Ea)	LRA (Ea)	Qty	FLA (Ea)	LRA (Ea)	Qty	Total Kw		
ACC03	374	457	8.3	61.8	1	-	-	-	0.74	13.9	1	0.37	12	20
ACC04	374	457	10	65.5	1	-	-	-	0.74	13.9	1	0.37	14	24
ACC05	374	457	12.1	101	1	-	-	-	0.74	13.9	1	0.37	16	28
ACC07	374	457	17.3	111	1	-	-	-	2.4	13.9	1	0.74	24	42
ACC010	374	457	12.1	101	1	12.1	101	1	0.74	13.9	2	0.74	29	41
ACC012	374	457	16.4	95	1	16.4	95	1	3	13.9	2	1.2	43	60
ACC015	374	457	17.3	111	1	17.3	111	1	3	13.9	2	1.2	45	63
ACC020	374	457	22.1	118	1	22.1	118	1	2.7	13.9	2	2.4	56	78
ACC025	374	457	27.1	173	1	27.1	173	1	2.7	13.9	2	2.4	67	94
ACC030	374	457	33.6	225	1	27.1	173	1	2.7	13.9	2	2.4	75	109
ACC035	374	457	22.1	118	2	19.2	118	2	2.7	13.9	4	4.8	100	123
ACC040	374	457	22.1	140	2	22.1	118	2	2.7	13.9	4	4.8	106	128
ACC045	374	457	27.1	173	2	27.1	173	2	2.7	13.9	4	4.8	128	155
ACC050	374	457	33.6	225	1	27.1	173	3	2.7	13.9	4	4.8	136	169
ACC055	374	457	33.6	225	2	27.1	173	2	2.7	13.9	4	4.8	142	176

Legend

RLA Rated Load Amps

FLA Full Load Amps

LRA Locked Rotor Amp

MCA Minimum Circuit Ampacity as per NEC 430-24

MOCP Maximum Over Current Protection

Note:

- i Main power must be provided from a single field supply with mounted fused disconnects using dual element time delay fuse or circuit breaker.
- ii Neutral line is required on 415V-3Ph-50Hz(4Wires) power supply.
- iii The compressor crankcase heaters must be energized for 12 hours before the unit is initially started or after a prolonged power failure.
- iv Type-1 Compressors are the big compressors or compressors with economizers and type-2 are the small compressors or compressors without economizers.
- v The $\pm 10\%$ voltage variation from the nominal is allowed for a short time only, not permanent.
- vi All field wiring must be in accordance with NEC or local standard.

CORRECTION FACTOR TABLES

- Altitude Correction Factor:**

The Unit ratings are based on sea level.

This correction factor is to be used for above sea level in order to get the required cooling capacity.

See table (1-a) and table (1-b)

ELEVATION ABOVE SEA LEVEL (F.T.)	CAPACITY CORRECTION FACTOR
0	1.00
2000	0.99
4000	0.98
6000	0.97
8000	0.96
10000	0.96

TABLE (1-a)

ELEVATION ABOVE SEA LEVEL (METER)	CAPACITY CORRECTION FACTOR
0	1.00
600	0.99
1200	0.98
1800	0.97
2400	0.96
3000	0.96

TABLE (1-b)

- Cooler Fouling Correction Factor:**

The Chillers are rated at a fouling factor of 0.00010 ft².hr.°F/btu (0.000018 m².°C/W)

This correction factor is to be used for other fouling factor values in order to get the required cooling capacity and power input.

See table (2-a) and table (2-b)

EVAPORATOR FOULING FACTOR (ft ² .hr.°F/btu)	CAPACITY CORRECTION FACTOR	POWER INPUT FACTORS	ARI STANDARDS
0.00010	1.000	1.000	ARI-550/590-98
0.00025	0.992	0.997	ARI-590-86
0.00050	0.978	0.990	ARI-590-81
0.00075	0.965	0.984	
0.00100	0.951	0.978	

TABLE (2-a)

EVAPORATOR FOULING FACTOR (m ² .°C/W)	CAPACITY CORRECTION FACTOR	POWER INPUT FACTORS	ARI STANDARDS
0.000018	1.000	1.000	ARI-550/590-98
0.000044	0.992	0.997	ARI-590-86
0.000088	0.978	0.990	ARI-590-81
0.000132	0.965	0.984	
0.000176	0.951	0.978	

TABLE (2-b)

CORRECTION FACTOR CURVES

- **ΔT Correction Factor :**

Cooling Capacity ratings are based on 10 °F (5.5 °C) for Chilled water ΔT .

This correction factor is to be used for other range of ΔT in order to get the required cooling capacity .
See Curve (1-a) and Curve (1-b)

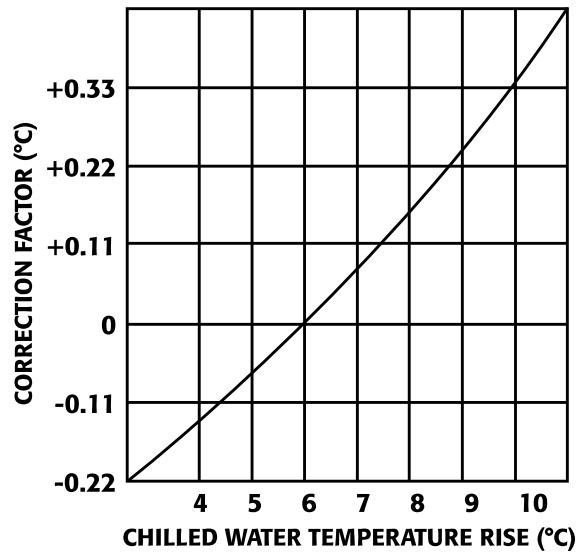

Curve (1-a)

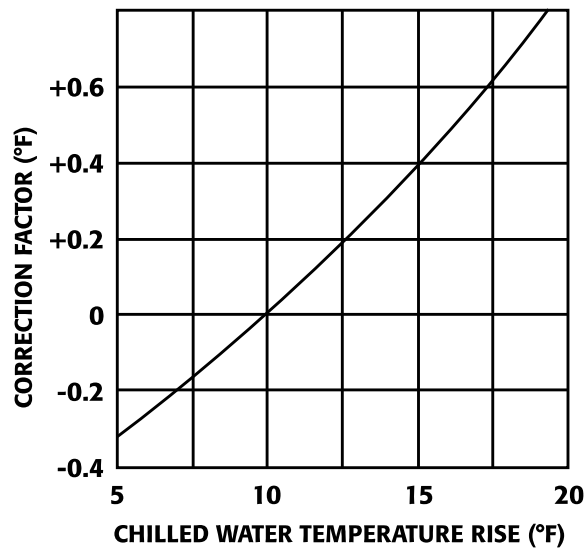

Curve (1-b)

SELECTION PROCEDURE

Coollex ACC Chiller should be selected with specific Design considerations , requirements and parameters of the intended application. Sample of the selection procedures are shown below:

Example 1 (English system)

- Design requirement

- 1-Cooling Capacity in tons (TR)
- 2- Leaving chilled water temperature in °F (LCWT)
- 3- Chilled water flow rate in GPM
- 4- Chilled water cooling range in °F
- 5- Design ambient temperature in °F
- 6- Altitude
- 7- Electrical power supply

- Selection sample

Select an air cooled chiller giving capacity of 6.5 TR to cool water from 54°F to 44°F ,altitude is 2000 ft above sea level ,water cooler fouling Factor is 0.00010 ft².hr.°F/Btu , design ambient temperature is 95°F and power supply is 415V/3Ph/50Hz

STEP-1

Entering the capacity performance data at given LCWT and ambient temperature. ACC 07 chiller unit at sea level will produce 6.9 tons and 6.5 kW compressor power input at 44°F leaving chilled water temperature with 10°F water temperature difference and 95°F ambient temperature.

For the conditions required, apply the correction factors for altitude 0.99 table (1-a) and fouling factor 1 table (2-a) for actual unit capacity and actual power input

Capacity=6.9x0.99x1=6.8 TR, which then exceeds the requirements. So the selection is correct

Power input =6.5x1=6.5 KW

Example 2 (Metric system)

- Design requirement

- 1-Cooling Capacity in kilowatt (kW)
- 2- Leaving chilled water temperature in °C (LCWT)
- 3- Chilled water flow rate in LPS
- 4- Chilled water cooling range in °C
- 5- Design ambient temperature in °C
- 6- Altitude
- 7- Electrical power supply

- Selection sample

Select an air cooled chiller giving capacity of 22.9 kW to cool water from 12.2°C to 6.7°C ,altitude is 600 meter above sea level, water cooler fouling Factor is 0.000018 m².°C/W, design ambient temperature is 35°C and power supply is 415V/3Ph/50Hz

STEP-1

Entering the capacity performance data at given LCWT and ambient temperature. ACC 07 chiller unit at sea level will produce 24.3 kW and 6.4 kW compressors Power input at 6.7°C leaving chilled water temperature with 5.5°C water temperature difference and 35°C ambient temperature.

For the conditions required, apply the correction factors for altitude 0.99 table (1-b) and fouling factor1 table (2-b) for actual unit capacity and actual power input

Capacity=24.3x0.99x1= 24.1 KW, which then exceeds the requirements. So the selection is correct

Power input =6.5x1=6.5 KW

SELECTION PROCEDURE

STEP-2

CHILLED WATER FLOW (GPM):

$$\text{Water GPM} = \frac{\text{Required capacity (Tons)} \times 24}{\text{Cooling Range, } \Delta T}$$

$$= \frac{6.5 \times 24}{10} = 15.6 \text{ GPM}$$

Referring to pressure drop curve (page # 18),

pressure drop at 15.6 GPM = 5.7 ft.H₂O for selected model.

STEP-2

CHILLED WATER FLOW (LPS):

$$\text{Water LPS} = \frac{\text{Required capacity (KW)} \times 0.239}{\text{Cooling Range, } \Delta T}$$

$$= \frac{22.9 \times 0.239}{5.5} = 0.99 \text{ LPS}$$

Referring to pressure drop curve (page # 18),

pressure drop at 0.99 L/S = 17.0 Kpa for selected model.

NOTES:

1- ELECTRICAL

Refer to electrical data at 415V/3Ph/50Hz, the main power wire size for ACC 07 is to be sized for a minimum circuit ampacity (MCA) of 24 Amps and maximum over current protection (MOCP) of 42 Amps.

2- CHILLED WATER PUMP SELECTION

For chilled water pump selection, add all pressure drop in the closed chilled water loop piping to the pressure drop calculated step 2

3- LCWT CORRECTION

Refer to curve (1-a) & (1-b) Add correction factor to design leaving chilled water temperature (LCWT) when chilled water temperature range is above 10°F or 6°C and subtract correction from design leaving chilled water temperature (LCWT) when water temperature range is below 10°F or 6°C.

WATER FLOW LIMIT AND COOLER WATER PRESSURE DROP CURVES

CURVE NO.	1				2			3			4			5				
MODELS	ACC03	ACC04	ACC05	ACC07	ACC010	ACC012	ACC015	ACC020	ACC025	ACC030	ACC035	ACC040	ACC045	ACC050	ACC055			
MINIMUM GPM	6.2	7.7	10.1	13.1	19.3	21.3	25.2	38.6	46.3	51.4	69.5	75.6	90.2	94.7	103.3			
Maximum GPM	9.2	11.6	15.1	18.8	29.4	29.4	37.4	59.6	66.2	75.1	104.1	113.7	133.7	141.6	155.7			

CONVERSION FACTOR : GPM = 0.063 L/S
: ft H2O=2.989 kPA

NOTES:
1- If the water flow rate outside these limits, please consult the factory
2- If the chiller has 2 evaporators, then the total water flow rate must be divided by 2 while applying the below curves.

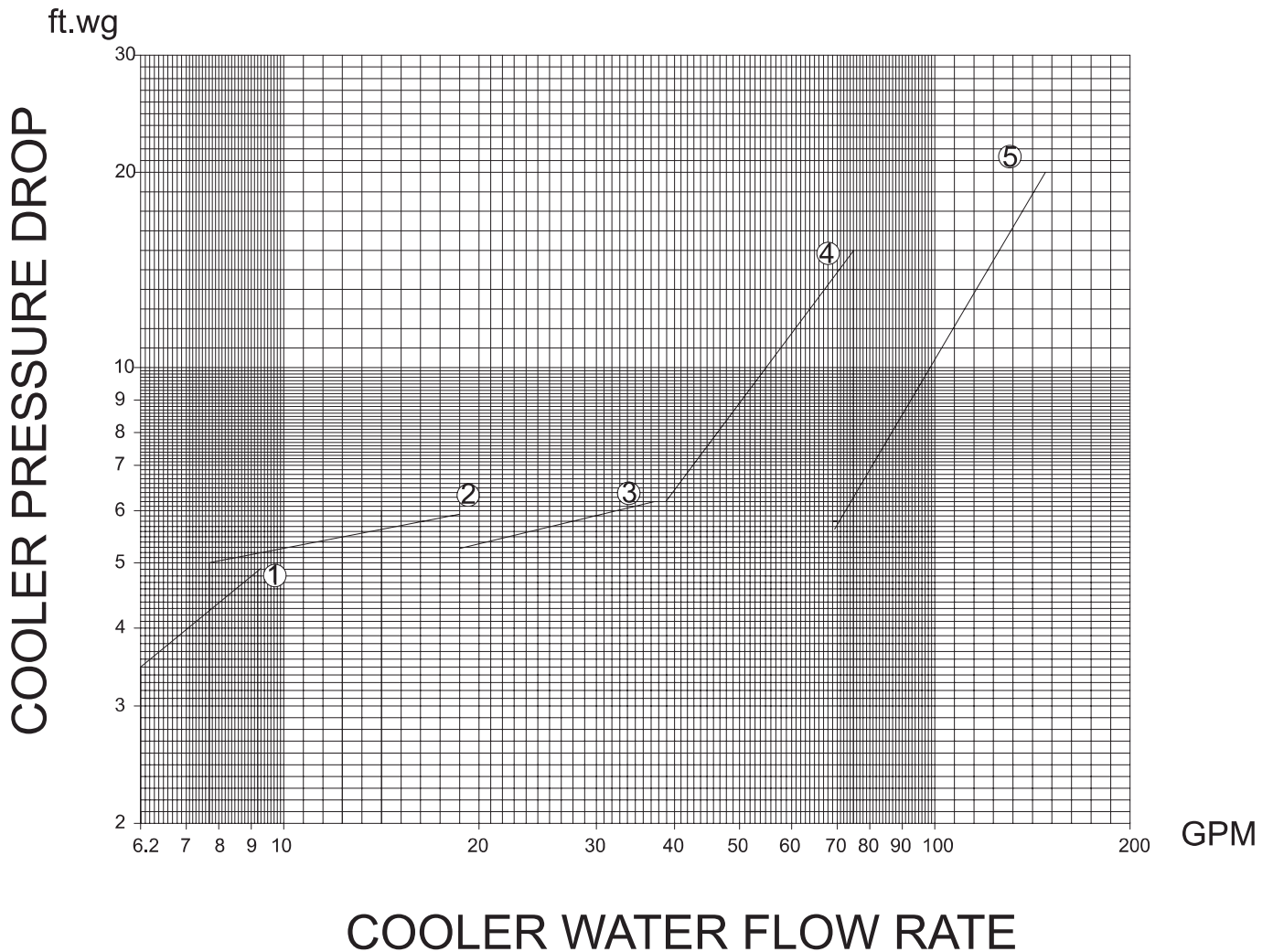

PERFORMANCE DATA TABLES-ENGLISH SYSTEM

LEAVING CHILLED WATER TEMP. (LCWT)	UNIT SIZE	85°F AMBIENT TEMPERATURE				95°F AMBIENT TEMPERATURE				105°F AMBIENT TEMPERATURE				115°F AMBIENT TEMPERATURE				118.4°F AMBIENT TEMPERATURE				125°F AMBIENT TEMPERATURE			
		CAP. (Tons)	COMP (kW)	WATER FLOW (GPM)	EER	CAP. (Tons)	COMP (kW)	WATER FLOW (GPM)	EER	CAP. (Tons)	COMP (kW)	WATER FLOW (GPM)	EER	CAP. (Tons)	COMP (kW)	WATER FLOW (GPM)	EER	CAP. (Tons)	COMP (kW)	WATER FLOW (GPM)	EER	CAP. (Tons)	COMP (kW)	WATER FLOW (GPM)	EER
40°F	ACC-03	3.3	2.8	7.9	12.5	3.1	3.2	7.4	10.4	3.0	3.6	7.2	9.0	2.8	4.0	6.7	7.6	2.7	4.2	6.5	7.2	2.6	4.5	6.2	6.3
	ACC-04	4.1	3.2	9.9	13.8	3.9	3.5	9.4	12.1	3.6	3.9	8.7	10.1	3.4	4.4	8.2	8.6	3.3	4.6	8.0	8.1	3.2	4.9	7.7	7.3
	ACC-05	5.5	4.4	13.1	13.7	5.2	4.9	12.4	11.7	4.8	5.4	11.6	10.1	4.5	6.1	10.9	8.4	4.4	6.3	10.6	8.0	4.2	6.8	10.1	7.1
	ACC-07	7.0	5.8	16.8	12.9	6.6	6.5	15.8	10.9	6.3	7.3	15.1	9.4	5.9	8.1	14.1	8.0	5.7	8.4	13.8	7.6	5.5	8.9	13.1	6.8
	ACC-010	10.5	8.8	25.2	13.2	10.0	9.8	24.0	11.4	9.4	11.0	22.5	9.6	8.8	12.3	21.0	8.1	8.5	12.8	20.4	7.6	8.0	13.7	19.3	6.7
	ACC-012	11.2	10.1	26.9	11.9	10.7	11.3	25.7	10.3	10.2	12.6	24.5	8.9	9.6	14.1	23.0	7.5	9.3	14.6	22.4	7.1	8.9	15.7	21.3	6.3
	ACC-015	13.5	11.7	32.4	12.6	12.8	13.1	30.7	10.7	12.1	14.6	28.9	9.1	11.3	16.3	27.2	7.8	11.0	16.9	26.5	7.4	10.5	18.0	25.2	6.6
	ACC-020	20.1	16.3	48.2	12.9	19.3	18.1	46.2	11.3	18.2	20.1	43.8	9.7	17.2	22.5	41.3	8.3	16.8	23.4	40.4	7.9	16.1	25.1	38.6	7.0
	ACC-025	24.0	19.9	57.7	12.9	22.8	22.3	54.8	11.1	21.8	25.1	52.3	9.5	20.6	28.2	49.3	8.0	20.1	29.3	48.3	7.6	19.3	31.5	46.3	6.8
	ACC-030	27.1	23.1	65.0	12.7	25.7	25.8	61.8	10.9	24.4	29.0	58.6	9.3	23.1	32.5	55.3	7.9	22.5	33.8	54.0	7.5	21.4	36.3	51.4	6.6
	ACC-035	35.8	28.7	86.0	12.8	34.3	32.1	82.3	11.2	32.7	35.8	78.4	9.7	30.8	40.0	73.9	8.2	30.2	41.6	72.4	7.8	28.9	44.7	69.5	7.0
	ACC-040	39.0	31.8	93.7	12.8	37.5	35.4	90.0	11.2	35.6	39.4	85.5	9.7	33.7	44.0	80.8	8.3	32.9	45.7	79.1	7.9	31.5	49.1	75.6	7.0
	ACC-045	46.0	38.8	110.5	12.7	44.1	43.6	105.8	10.9	42.1	49.0	101.1	9.4	40.0	55.0	95.9	8.0	39.2	57.2	94.0	7.6	37.6	61.6	90.2	6.8
	ACC-050	48.7	42.3	116.9	12.4	46.7	47.4	112.0	10.7	44.5	53.2	106.8	9.2	42.0	59.7	100.9	7.8	41.1	62.2	98.8	7.4	39.4	67.0	94.7	6.6
ACC-055	54.1	46.4	129.8	12.7	51.7	51.8	124.1	11.0	49.1	58.1	117.9	9.4	46.2	65.2	111.0	7.9	45.2	67.9	108.4	7.5	43.1	73.1	103.3	6.6	

42°F	ACC-03	3.4	2.8	8.2	12.9	3.2	3.2	7.7	10.7	3.0	3.6	7.2	9.0	2.8	4.0	6.7	7.6	2.7	4.2	6.5	7.2	2.6	4.5	6.2	6.3
	ACC-04	4.1	3.2	9.9	13.8	3.9	3.5	9.4	12.1	3.7	3.9	8.9	10.4	3.5	4.4	8.4	8.8	3.4	4.6	8.2	8.3	3.3	5.0	7.9	7.4
	ACC-05	5.6	4.4	13.3	14.0	5.3	4.9	12.6	12.0	4.9	5.5	11.9	10.1	4.6	6.1	11.1	8.6	4.5	6.3	10.9	8.1	4.3	6.8	10.4	7.2
	ACC-07	7.0	5.8	16.8	12.9	6.7	6.5	16.1	11.0	6.3	7.3	15.1	9.4	6.0	8.1	14.3	8.1	5.8	8.4	14.0	7.7	5.6	9.0	13.3	6.8
	ACC-010	10.8	8.9	26.0	13.5	10.3	9.9	24.7	11.6	9.7	11.1	23.2	9.8	9.1	12.4	21.8	8.3	8.9	12.9	21.2	7.8	8.4	13.9	20.3	6.9
	ACC-012	11.5	10.2	27.7	12.1	11.0	11.4	26.5	10.5	10.5	12.7	25.2	9.1	9.9	14.2	23.7	7.7	9.6	14.7	23.1	7.3	9.2	15.8	22.0	6.5
	ACC-015	13.7	11.8	32.9	12.7	13.1	13.2	31.4	10.9	12.4	14.7	29.7	9.3	11.6	16.4	27.9	7.9	11.4	17.0	27.3	7.5	10.8	18.2	26.0	6.7
	ACC-020	20.4	16.3	48.9	13.1	19.6	18.1	47.0	11.5	18.6	20.2	44.7	9.9	17.5	22.5	42.0	8.4	17.1	23.4	41.1	8.0	16.4	25.1	39.3	7.1
	ACC-025	24.4	20.1	58.6	13.0	23.4	22.5	56.1	11.3	22.4	25.3	53.6	9.7	21.1	28.4	50.7	8.2	20.7	29.6	49.7	7.8	19.9	31.8	47.7	7.0
	ACC-030	27.5	23.3	66.0	12.8	26.4	26.0	63.3	11.1	25.0	29.2	60.1	9.5	23.7	32.7	56.9	8.1	23.1	34.1	55.5	7.6	22.0	36.7	52.9	6.8
	ACC-035	37.1	28.9	89.0	13.2	35.5	32.2	85.3	11.5	33.8	36.0	81.1	9.9	32.0	40.2	76.9	8.5	31.4	41.8	75.3	8.1	30.1	44.9	72.2	7.3
	ACC-040	40.4	32.0	96.9	13.2	38.8	35.5	93.2	11.6	37.0	39.6	88.7	10.0	34.9	44.2	83.8	8.6	34.2	46.0	82.0	8.1	32.8	49.4	78.6	7.3
	ACC-045	47.6	39.1	114.2	13.0	45.6	43.9	109.5	11.2	43.6	49.3	104.6	9.7	41.4	55.3	99.4	8.3	40.6	57.6	97.4	7.8	39.0	62.0	93.7	7.0
	ACC-050	50.4	42.6	120.9	12.8	48.3	47.7	115.9	11.0	46.0	53.6	110.5	9.5	43.6	60.1	104.6	8.1	42.7	62.6	102.4	7.6	40.9	67.4	98.1	6.8
ACC-055	55.6	46.7	133.5	13.0	53.3	52.2	127.8	11.2	50.6	58.5	121.4	9.6	47.7	65.6	114.5	8.1	46.6	68.3	111.8	7.7	44.5	73.6	106.8	6.8	

NOTES:-

- 1- The ACC chillers are rated with ARI - 550/590-98 standard.
- 2- Capacity ratings (CAP) are based on (10°F) water range , (0.0001 ft².h°F/Btu) fouling factor in evaporator and zero altitude.
- 3- Direct interpolation is permissible. Do not extrapolate.
- 4- Leaving chilled water temperature. (LCWT)
- 5- Power input (kW) is for compressor only.
- 6- Energy Efficiency Ratio (EER) is for the overall unit, refer to electrical data for fan power input
- 7- Water flow rate in Gallons Per Minute (GPM)

PERFORMANCE DATA TABLES-METRIC SYSTEM

LEAVING CHILLED WATER TEMP. (LCWT)	UNIT SIZE	29°C AMBIENT TEMPERATURE				35°C AMBIENT TEMPERATURE				40°C AMBIENT TEMPERATURE				46°C AMBIENT TEMPERATURE				48°C AMBIENT TEMPERATURE				52°C AMBIENT TEMPERATURE			
		CAP. (kW)	COMP (kW)	WATER FLOW (L/S)	COP	CAP. (kW)	COMP (kW)	WATER FLOW (L/S)	COP	CAP. (kW)	COMP (kW)	WATER FLOW (L/S)	COP	CAP. (kW)	COMP (kW)	WATER FLOW (L/S)	COP	CAP. (kW)	COMP (kW)	WATER FLOW (L/S)	COP	CAP. (kW)	COMP (kW)	WATER FLOW (L/S)	COP
		4.5°C	ACC-03	11.6	2.8	0.5	3.7	10.9	3.2	0.5	3.0	10.5	3.6	0.5	2.6	9.8	4.0	0.4	2.2	9.5	4.2	0.4	2.1	9.1	4.5
	ACC-04	14.5	3.2	0.6	4.1	13.8	3.5	0.6	3.6	12.7	3.9	0.5	3.0	12.0	4.4	0.5	2.5	11.7	4.6	0.5	2.4	11.2	4.9	0.5	2.1
	ACC-05	19.2	4.4	0.8	4.0	18.1	4.9	0.8	3.4	17.0	5.4	0.7	3.0	15.9	6.1	0.7	2.5	15.6	6.3	0.7	2.3	14.9	6.8	0.6	2.1
	ACC-07	24.6	5.8	1.1	3.8	23.2	6.5	1.0	3.2	22.1	7.3	1.0	2.8	20.6	8.1	0.9	2.3	20.2	8.4	0.9	2.2	19.2	8.9	0.8	2.0
	ACC-010	36.9	8.8	1.6	3.9	35.1	9.8	1.5	3.3	33.0	11.0	1.4	2.8	30.8	12.3	1.3	2.4	29.9	12.8	1.3	2.2	28.3	13.7	1.2	2.0
	ACC-012	39.5	10.1	1.7	3.5	37.7	11.3	1.6	3.0	35.9	12.6	1.5	2.6	33.7	14.1	1.5	2.2	32.8	14.6	1.4	2.1	31.2	15.7	1.3	1.8
	ACC-015	47.5	11.7	2.0	3.7	44.9	13.1	1.9	3.1	42.4	14.6	1.8	2.7	39.8	16.3	1.7	2.3	38.9	16.9	1.7	2.2	36.9	18.0	1.6	1.9
	ACC-020	70.6	16.3	3.0	3.8	67.7	18.1	2.9	3.3	64.1	20.1	2.8	2.8	60.5	22.5	2.6	2.4	59.1	23.4	2.5	2.3	56.5	25.1	2.4	2.1
	ACC-025	84.6	19.9	3.6	3.8	80.3	22.3	3.5	3.2	76.6	25.1	3.3	2.8	72.3	28.2	3.1	2.4	70.8	29.3	3.0	2.2	67.9	31.5	2.9	2.0
	ACC-030	95.3	23.1	4.1	3.7	90.5	25.8	3.9	3.2	85.8	29.0	3.7	2.7	81.1	32.5	3.5	2.3	79.1	33.8	3.4	2.2	75.3	36.3	3.2	1.9
	ACC-035	126.1	28.7	5.4	3.8	120.6	32.1	5.2	3.3	114.8	35.8	4.9	2.8	108.3	40.0	4.7	2.4	106.1	41.6	4.6	2.3	101.8	44.7	4.4	2.1
	ACC-040	137.3	31.8	5.9	3.8	131.9	35.4	5.7	3.3	125.3	39.4	5.4	2.8	118.5	44.0	5.1	2.4	115.9	45.7	5.0	2.3	110.8	49.1	4.8	2.1
	ACC-045	161.9	38.8	7.0	3.7	155.0	43.6	6.7	3.2	148.2	49.0	6.4	2.8	140.6	55.0	6.1	2.4	137.7	57.2	5.9	2.2	132.2	61.6	5.7	2.0
	ACC-050	171.3	42.3	7.4	3.6	164.1	47.4	7.1	3.1	156.5	53.2	6.7	2.7	147.8	59.7	6.4	2.3	144.7	62.2	6.2	2.2	138.7	67.0	6.0	1.9
	ACC-055	190.2	46.4	8.2	3.7	181.9	51.8	7.8	3.2	172.8	58.1	7.4	2.7	162.7	65.2	7.0	2.3	158.8	67.9	6.8	2.2	151.4	73.1	6.5	1.9

5.6°C	ACC-03	12.0	2.8	0.5	3.8	11.2	3.2	0.5	3.1	10.5	3.6	0.5	2.6	9.8	4.0	0.4	2.2	9.5	4.2	0.4	2.1	9.1	4.5	0.4	1.9
	ACC-04	14.5	3.2	0.6	4.1	13.8	3.5	0.6	3.6	13.0	3.9	0.6	3.1	12.3	4.4	0.5	2.6	12.1	4.6	0.5	2.4	11.6	5.0	0.5	2.2
	ACC-05	19.6	4.4	0.8	4.1	18.5	4.9	0.8	3.5	17.4	5.5	0.7	3.0	16.3	6.1	0.7	2.5	15.9	6.3	0.7	2.4	15.2	6.8	0.7	2.1
	ACC-07	24.6	5.8	1.1	3.8	23.5	6.5	1.0	3.2	22.1	7.3	1.0	2.8	21.0	8.1	0.9	2.4	20.5	8.4	0.9	2.3	19.6	9.0	0.8	2.0
	ACC-010	38.0	8.9	1.6	3.9	36.2	9.9	1.6	3.4	34.1	11.1	1.5	2.9	31.9	12.4	1.4	2.4	31.1	12.9	1.3	2.3	29.7	13.9	1.3	2.0
	ACC-012	40.6	10.2	1.7	3.6	38.8	11.4	1.7	3.1	36.9	12.7	1.6	2.7	34.8	14.2	1.5	2.3	33.9	14.7	1.5	2.1	32.2	15.8	1.4	1.9
	ACC-015	48.2	11.8	2.1	3.7	46.0	13.2	2.0	3.2	43.5	14.7	1.9	2.7	40.9	16.4	1.8	2.3	39.9	17.0	1.7	2.2	38.0	18.2	1.6	2.0
	ACC-020	71.7	16.3	3.1	3.8	68.8	18.1	3.0	3.4	65.6	20.2	2.8	2.9	61.6	22.5	2.7	2.5	60.2	23.4	2.6	2.3	57.6	25.1	2.5	2.1
	ACC-025	85.9	20.1	3.7	3.8	82.2	22.5	3.5	3.3	78.6	25.3	3.4	2.8	74.3	28.4	3.2	2.4	72.8	29.6	3.1	2.3	69.9	31.8	3.0	2.0
	ACC-030	96.7	23.3	4.2	3.8	92.7	26.0	4.0	3.3	88.0	29.2	3.8	2.8	83.3	32.7	3.6	2.4	81.3	34.1	3.5	2.2	77.5	36.7	3.3	2.0
	ACC-035	130.4	28.9	5.6	3.9	125.0	32.2	5.4	3.4	118.8	36.0	5.1	2.9	112.7	40.2	4.9	2.5	110.3	41.8	4.8	2.4	105.8	44.9	4.6	2.1
	ACC-040	142.0	32.0	6.1	3.9	136.6	35.5	5.9	3.4	130.0	39.6	5.6	2.9	122.8	44.2	5.3	2.5	120.2	46.0	5.2	2.4	115.2	49.4	5.0	2.1
	ACC-045	167.4	39.1	7.2	3.8	160.5	43.9	6.9	3.3	153.2	49.3	6.6	2.8	145.6	55.3	6.3	2.4	142.8	57.6	6.1	2.3	137.3	62.0	5.9	2.1
	ACC-050	177.1	42.6	7.6	3.7	169.9	47.7	7.3	3.2	161.9	53.6	7.0	2.8	153.2	60.1	6.6	2.4	150.0	62.6	6.5	2.2	143.8	67.4	6.2	2.0
	ACC-055	195.6	46.7	8.4	3.8	187.3	52.2	8.1	3.3	177.9	58.5	7.7	2.8	167.7	65.6	7.2	2.4	163.9	68.3	7.1	2.3	156.5	73.6	6.7	2.0

NOTES:-

- 1- The ACC chillers are rated with ARI - 550/590-98 standard.
- 2- Capacity ratings (CAP) are based on (5.5°C) water range, (0.000018 m²°C/W) fouling factor in evaporator and zero altitude.
- 3- Direct interpolation is permissible. Do not extrapolate.
- 4- Leaving chilled water temperature. (LCWT)
- 5- Power input (kW) is for compressor only.
- 6- Coefficient of performance (COP) is for the overall unit, refer to electrical data for fan power input
- 7- Water flow rate in liters Per second ((L/S)

UNIT DIMENSIONS

AC -03/04TR

ALL DIMENSIONS ARE IN MM

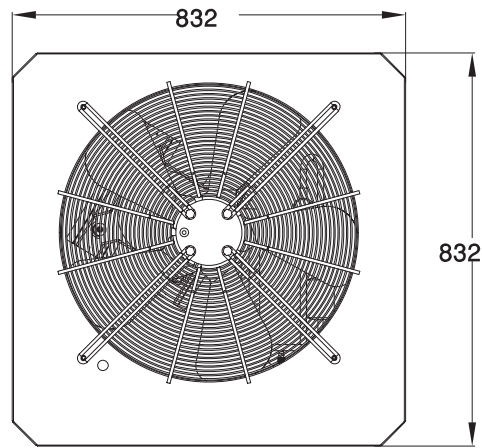

TOP VIEW

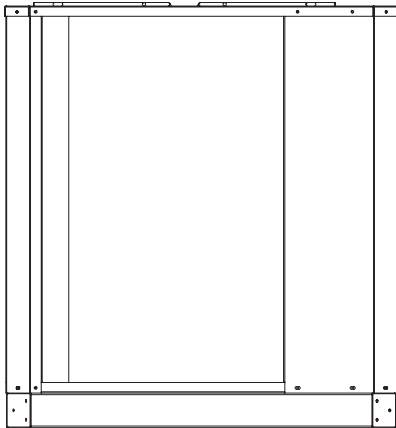

SIDE VIEW

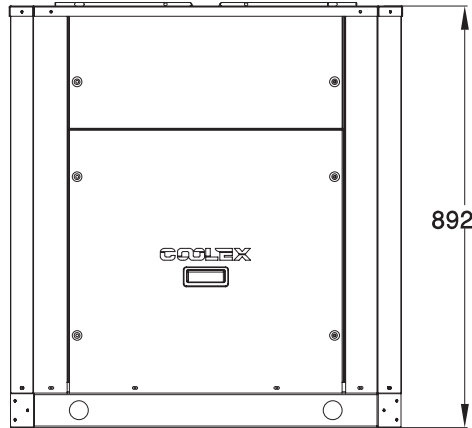

FRONT VIEW

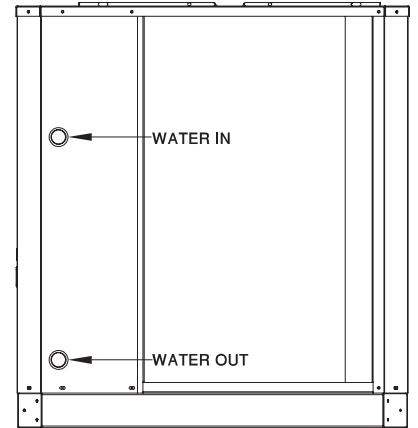

SIDE VIEW

UNIT DIMENSIONS

AC -05TR ALL DIMENSIONS ARE IN MM

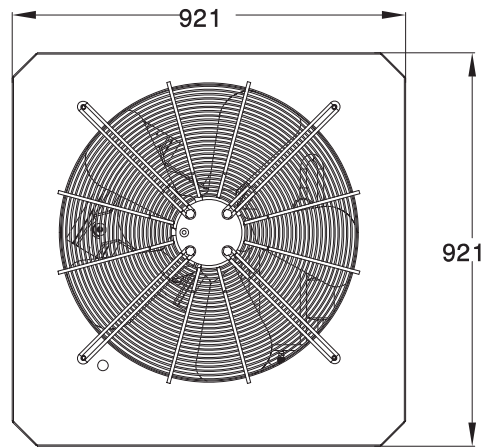

TOP VIEW

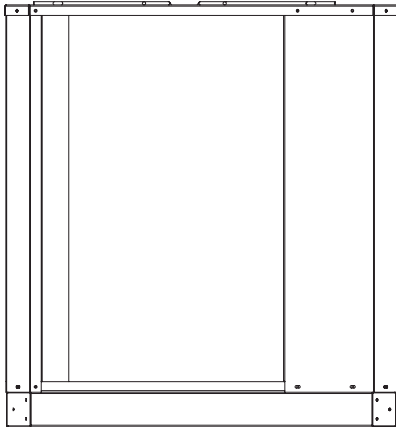

SIDE VIEW

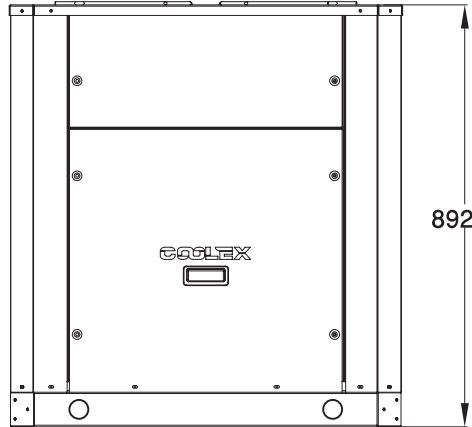

FRONT VIEW

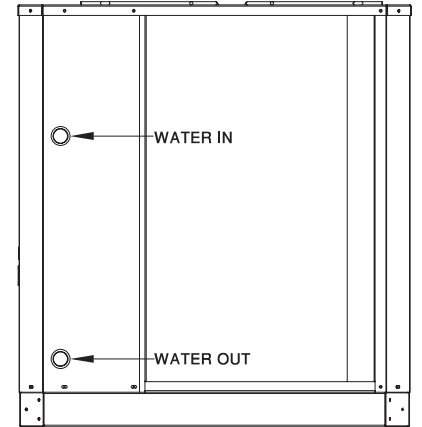

SIDE VIEW

UNIT DIMENSIONS

AC -07TR

ALL DIMENSIONS ARE IN MM

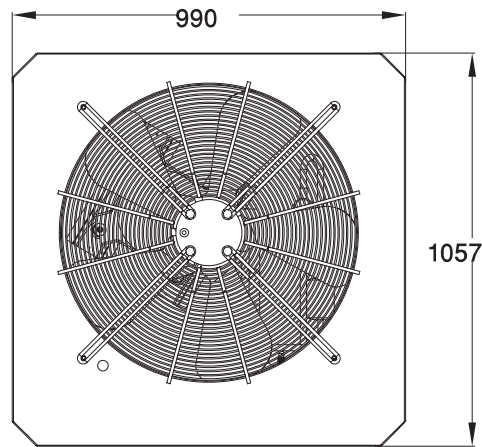

TOP VIEW

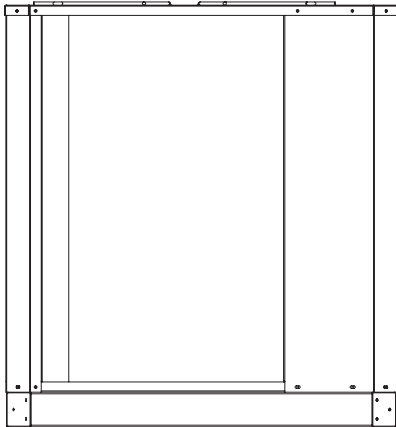

SIDE VIEW

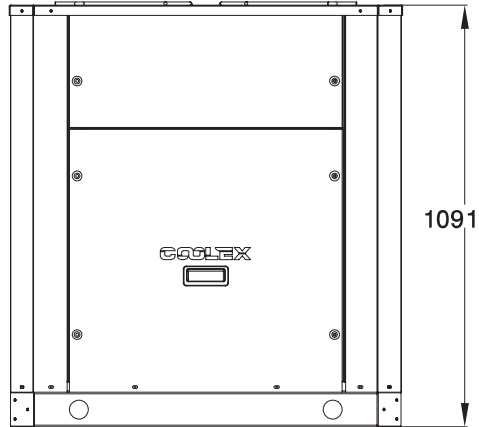

FRONT VIEW

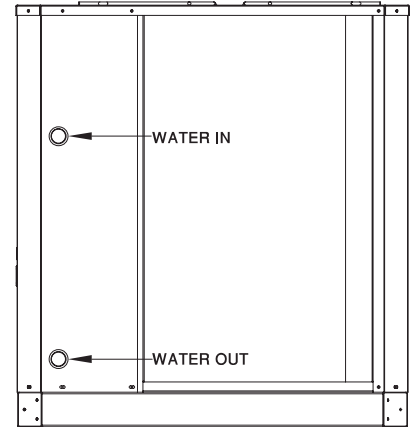

SIDE VIEW

UNIT DIMENSIONS

AC -010TR

ALL DIMENSIONS ARE IN MM

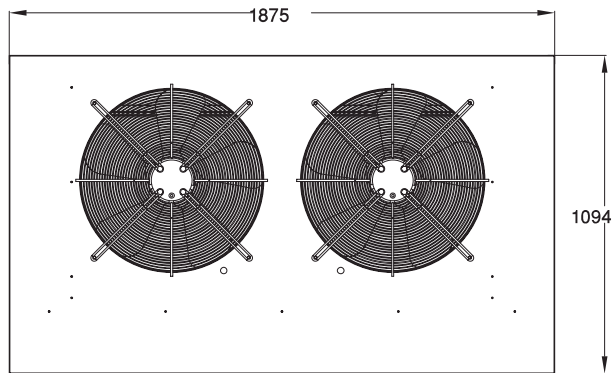

TOP VIEW

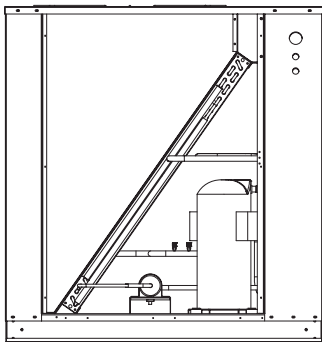

SIDE VIEW

WATER IN
WATER OUT

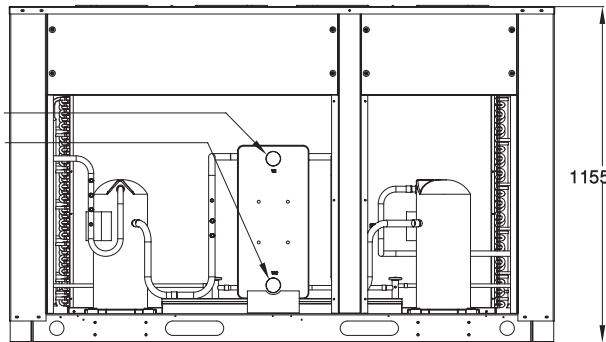

FRONT VIEW

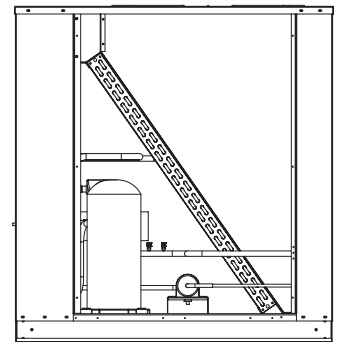

SIDE VIEW

UNIT DIMENSIONS

AC -012/015TR ALL DIMENSIONS ARE IN MM

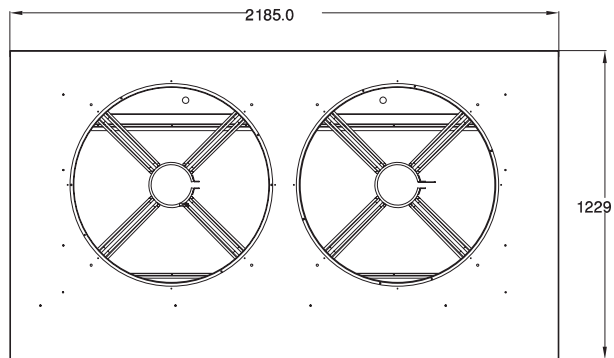

TOP VIEW

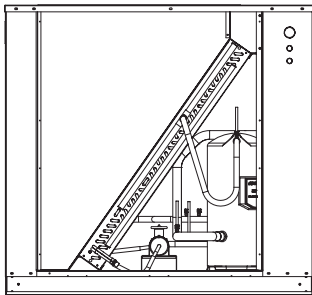

SIDE VIEW

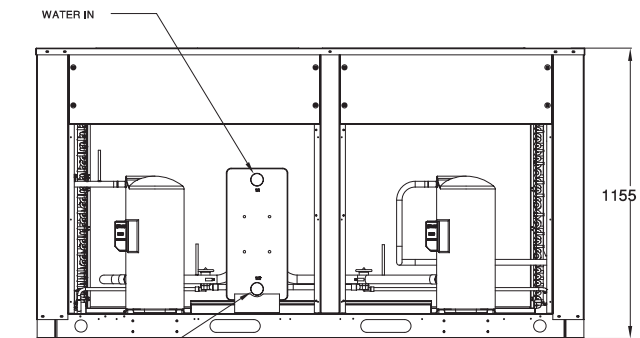

FRONT VIEW

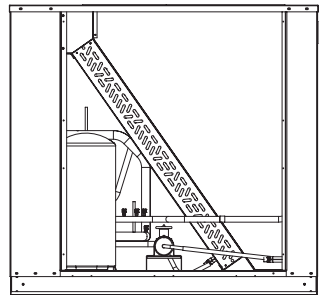

SIDE VIEW

UNIT DIMENSIONS

AC -020/025/030TR

ALL DIMENSIONS ARE IN MM

- ① Water In
- ② Water Out
- ③ Electrical Power Inlet
- ④ Lifting Pints
- ⑤ Electrical Control Box

All dimensions are in mm
Tolerance : ± 5mm

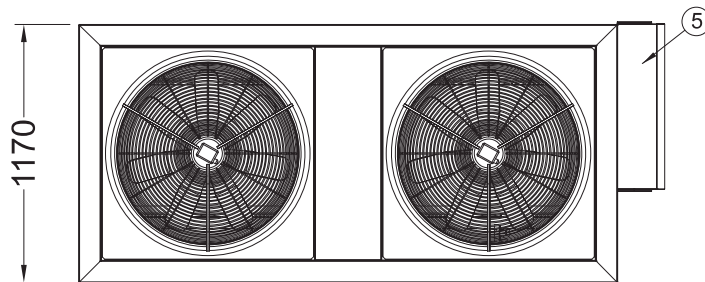

Top View

Discharge Condenser Air

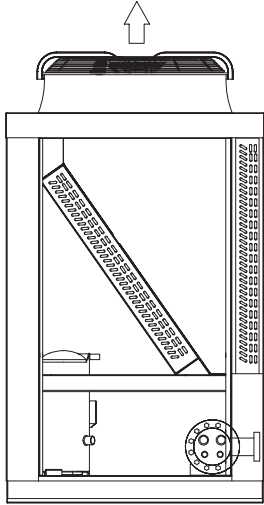

End View

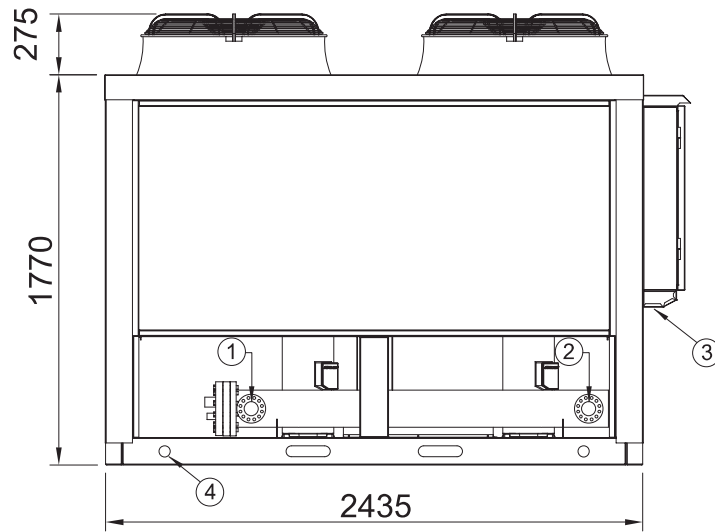

Front View

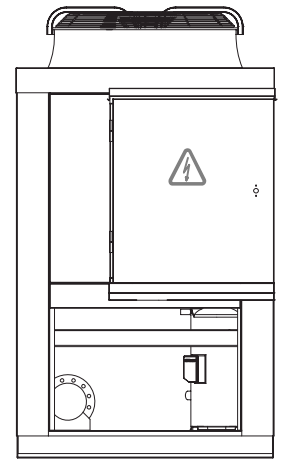

End View

UNIT DIMENSIONS

AC -035/040/045/050/055 TR

ALL DIMENSIONS ARE IN MM

- ① Water In
- ② Water Out
- ③ Electrical Power Inlet
- ④ Lifting Pints
- ⑤ Electrical Control Box

All dimensions are in mm
Tolerance : ± 5mm

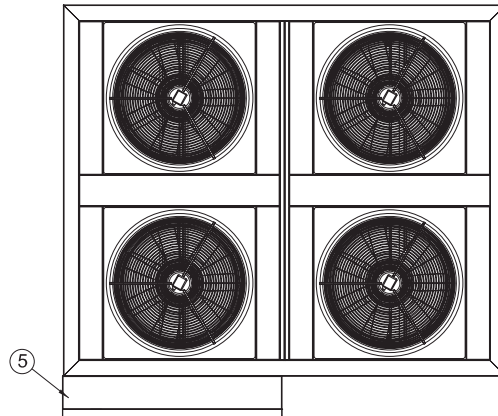

Top View

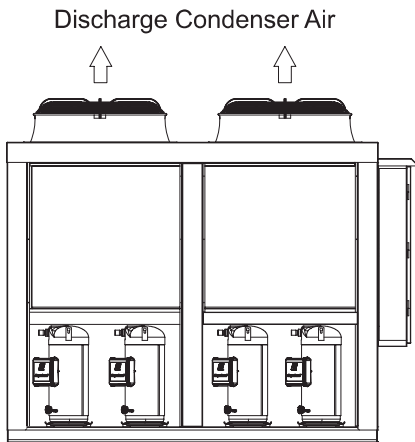

End View

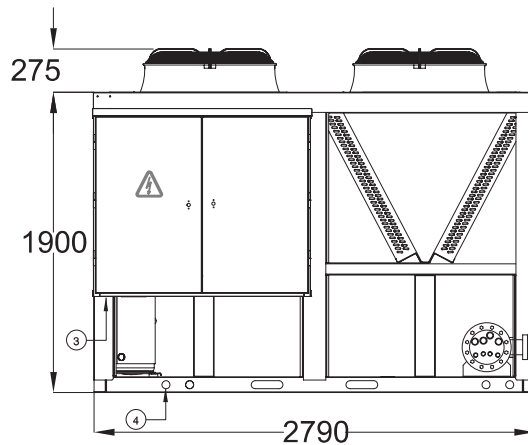

Front View

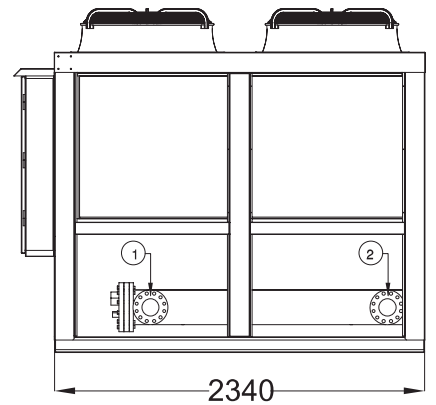

End View

TYPICAL WIRING DIAGRAM

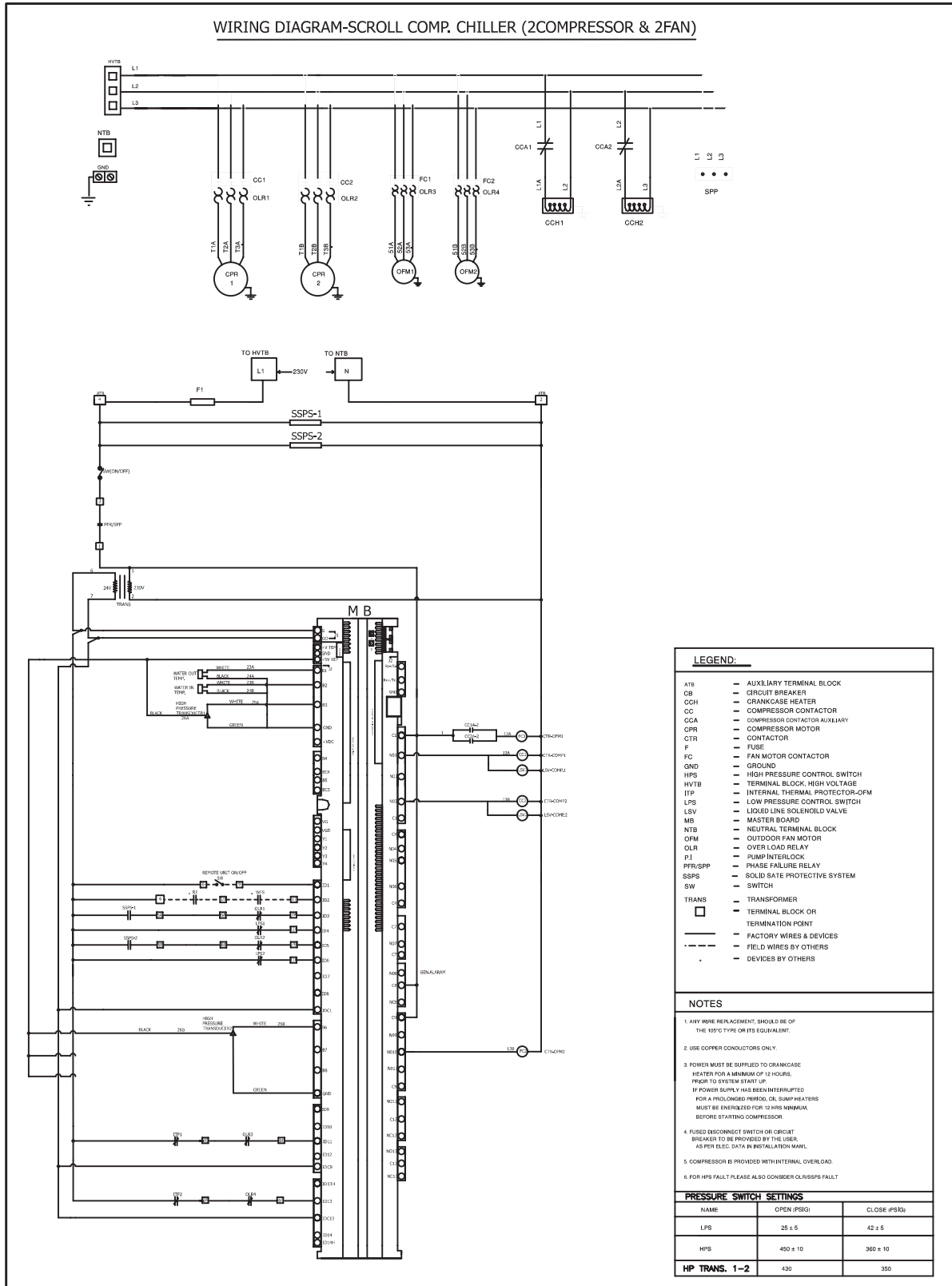

MICROPROCESSOR OPERATION SEQUENCE

1. Configuration

The Carel controller can control up to 4 compressors. All the interactions with the machine are made through the display. The two water temperature sensors (RWT and LWT) are connected to the controller.

2. Machine starting

For initial start up, the following conditions must be met:

- All power supplied to the unit shall be energized for 12 hours.
- Control power switch shall be on for at least 5 minutes.
- All safety conditions must be satisfied *Press ON/OFF key on the key pad.
- The "ON" LED is lit.
- Chilled water pump running and water flow switch contact is closed.
- Customer interlock contact is closed, if any.
- On the main screen is showed the status "STARTING"
- After 60 seconds of delay the system will be running (i.e. compressors/circuits control is activated).

3. Machine shut down

- The machine is halted pushing again the ON/OFF key; the "ON" LED is switched off; on the main screen is showed the status "STOPPING".
- On the main screen is showed the status "SYSTEM OFF".

4. External Enable Unit

can be switched on and off also from digital input.

5. Lock compressor by digital input

Each compressor may be locked for service or other reason through digital input .

6. System Setup

To enter into setup menu the MENU key has to be pressed from any screen.

To enter into every single setup menu to change some parameters, you have to press the SET key.

To store a modified parameter, you have to press the SET key, but if you press the ESC key, you'll come back to the previous menu with no storing.

MICROPROCESSOR TROUBLESHOOTING

1-Not RUNNING

- a-Check power supply cable connection.
- b- Check if the power supply voltage is into the specified limits.
- c- (Check the fuse, replace with same type if blown.

2-No LCD backlight on the display panel

- a-Check the supply voltage (24VAC) to the board.

3-Analog values reading incorrectly

- a-Check and tight connections of the probes to the board.
- b-Check the probe cable, test for short circuit.
- c-Check the polarity of the pressure transducer on the board.

4-Digital input reading incorrectly

- a- Check the auxiliary voltage of 24VAC is available between the terminal block.
- b- Check the connections of the controller.

5-Digital outputs not responding

- a- Check the digital output cabling and connections.

6-Analog outputs not responding

- a- Check analog output cabling and connections.

INSTALLATION CLEARANCE

AC 03/04/05/07

ALL DIMENSIONS ARE IN MM

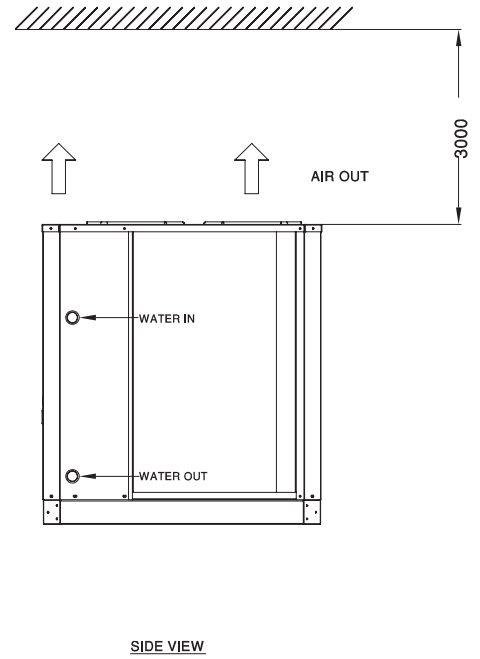
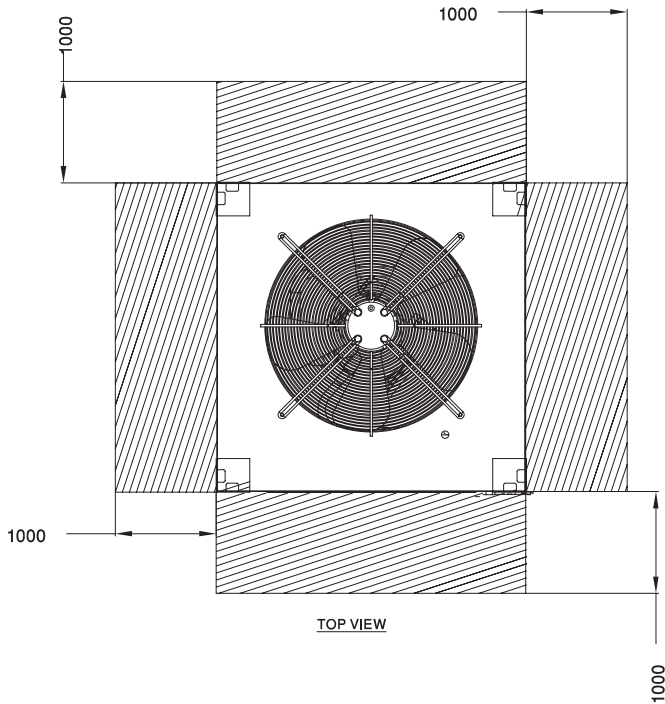

AC 010/012/015/020/025/030

ALL DIMENSIONS ARE IN MM

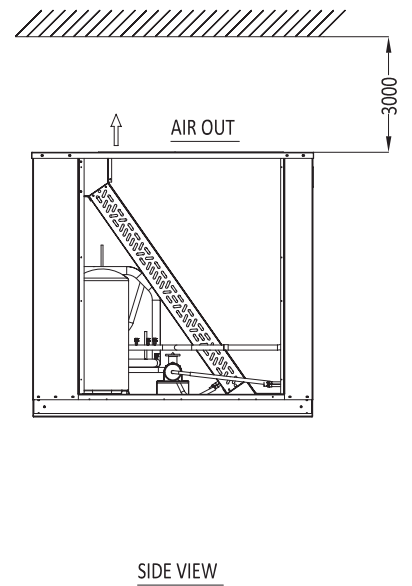
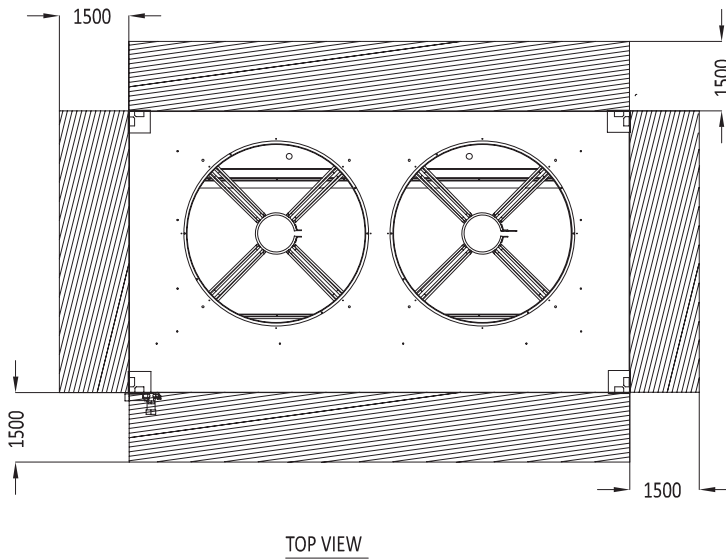

- Pit installations are not recommended where circulation of hot condenser air can take place and it will severely affect unit efficiency (EER) causing high pressure or fan motor temperature trips.

INSTALLATION CLEARANCE

AC 035/040/045/050/055
 ALL DIMENSIONS ARE IN MM

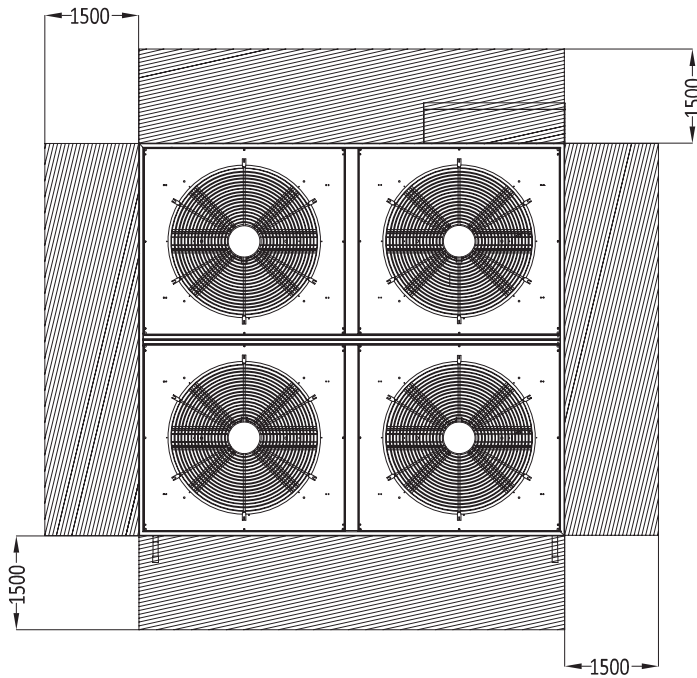

TOP VIEW

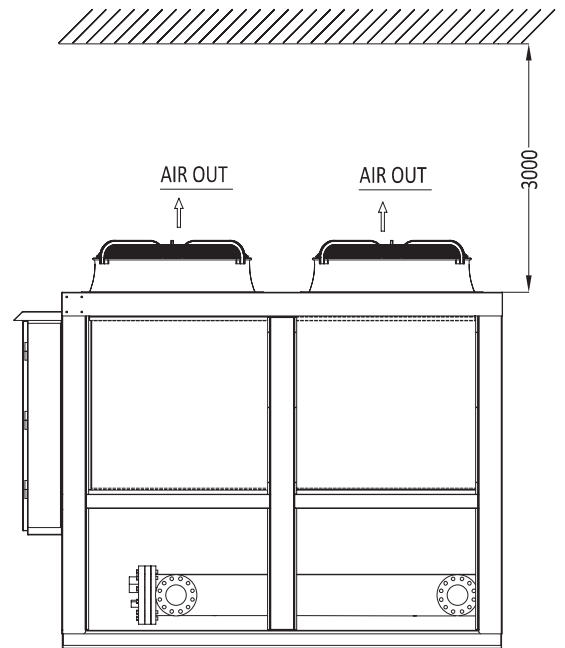

SIDE VIEW

- Pit installations are not recommended where circulation of hot condenser air can take place and it will severely affect unit efficiency (EER) causing high pressure or fan motor temperature trips.

RIGGING INSTRUCTIONS

COOLEX chillers are designed for overhead rigging only, for this purpose the base channel has been extended beyond the sides of the unit with rigging holes. Use a spreader frame above the unit to keep the cables vertical and away from the sides.

Run the cables to a central suspension point so that the angle from the horizontal is not less than 45°. As an added protection, put plywood sheets on the sides of the unit behind cables while rigging. Raise and set the unit carefully.

ATTENTION TO RIGGERS

The positions of the rigging slings should be as per the below given drawings.

Lifting points are so provided in the unit as to evenly distribute the units load..

Center of gravity of the unit is not necessarily its center line.

Ensure that the center of gravity aligns with the main lifting pole before lifting the unit.

To avoid damage to the unit by the rigging slings, use spreader bars as shown below.

CAUTION

All panels should be in place when rigging.

Care must be taken to avoid damage to the coils during handling.

Insert packing material between coils & slings as necessary.

AC 03/04/05/07

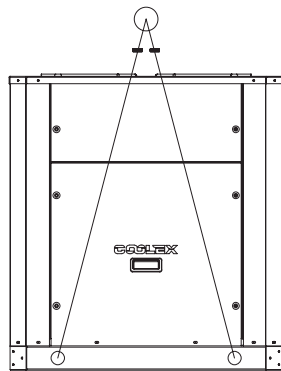

FRONT VIEW

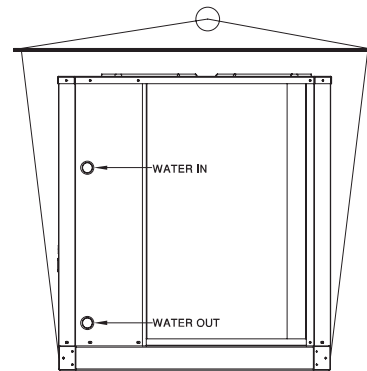

SIDE VIEW

AC 010/012/015

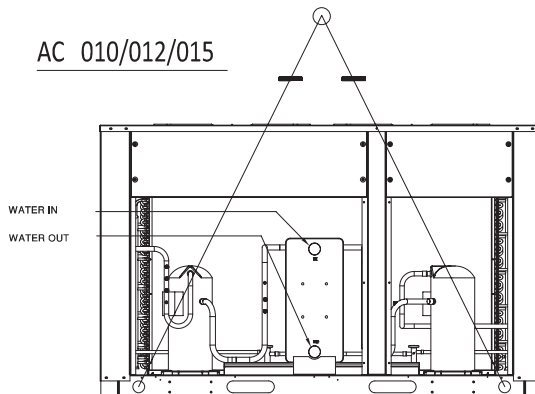

FRONT VIEW

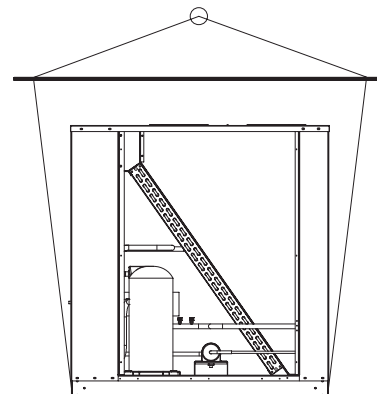

SIDE VIEW

MOUNTING LOCATION AND DISTRIBUTION LOAD

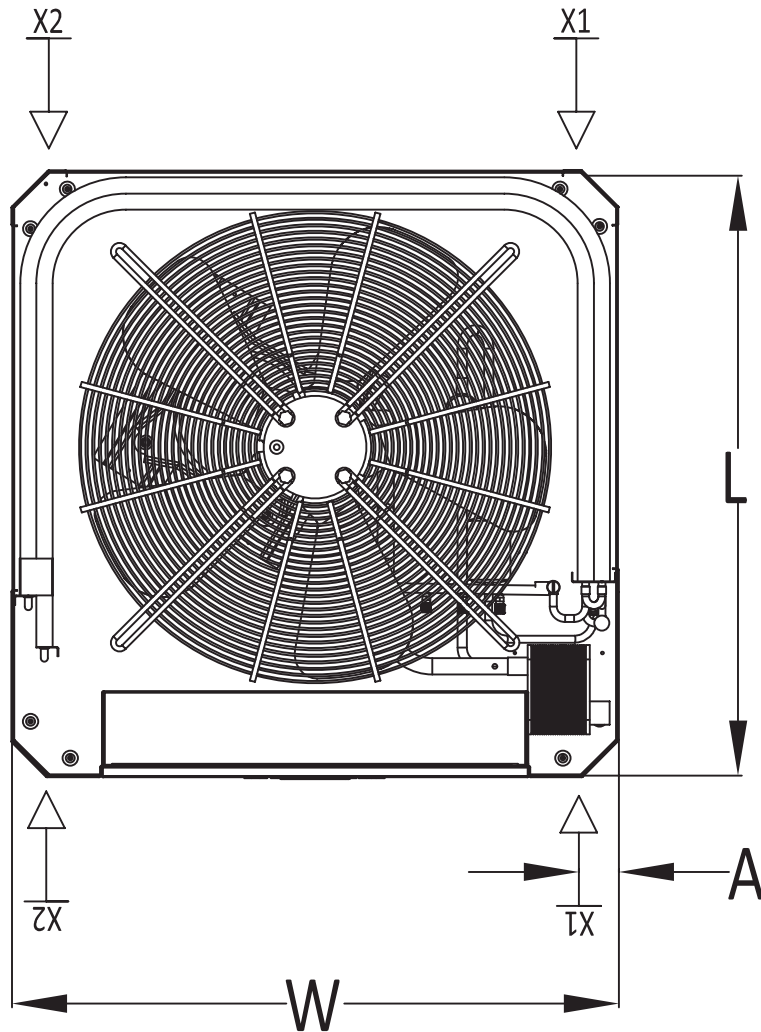

LOAD DISTRIBUTION

MODEL	L (mm)	W (mm)	A (mm)	X1 (kg)	X2 (kg)
ACC-03	832	832	75	30.0	35.7
ACC-04	832	832	75	32.5	39.5
ACC-05	921	921	75	43.5	49.0
ACC-07	1057	990	75	52.5	62.5

MOUNTING LOCATION AND DISTRIBUTION LOAD

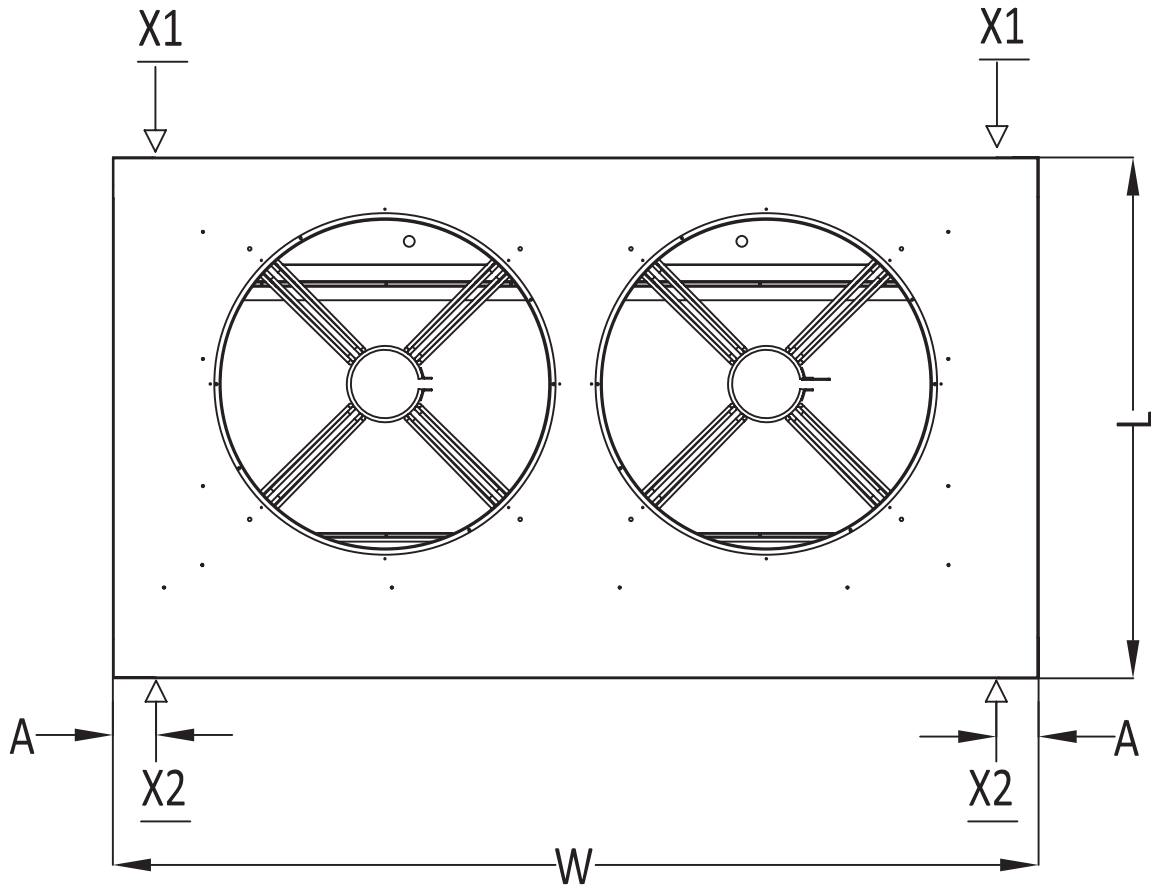

LOAD DISTRIBUTION					
MODEL	L (mm)	W (mm)	A (mm)	X1 (kg)	X2 (kg)
ACC-010	1094	1875	75	55.0	77.5
ACC-012	1229	1875	75	137.5	152.5
ACC-015	1229	1875	75	131.5	160.0
ACC-020	2660	1175	75	234.7	255.0
ACC-025	2660	1175	75	235.4	256.2
ACC-030	2660	1175	75	271.0	300.0

MOUNTING LOCATION AND DISTRIBUTION LOAD

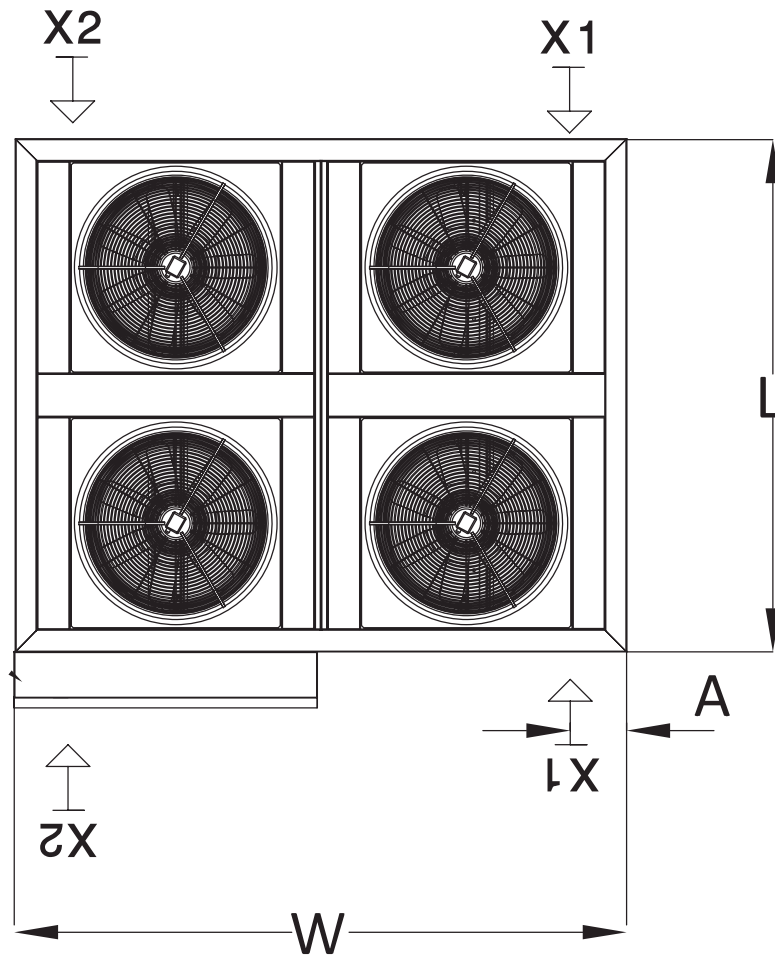

LOAD DISTRIBUTION					
MODEL	L (mm)	W (mm)	A (mm)	X1 (kg)	X2 (kg)
ACC-035	2805	2605	75	410.0	447.5
ACC-040	2805	2605	75	482.5	500.0
ACC-045	2805	2605	75	530.0	545.0
ACC-050	2805	2605	75	620.0	562.0
ACC-055	2805	2605	75	625.0	675.0

NOTES

About RIC

Refrigeration Industries Company (KSE 504) is a group holding company with diversified interests in manufacturing, contracting and services. Recognized regionally for our engineering capabilities and management excellence, RIC and its subsidiaries offer a wide range of high quality products and services that cater to both residential and commercial customers, in the areas of climate control technologies and specialized storage solutions.

In view of the growing Kuwait infrastructure and the limitations imposed on it by the country's arid climate, the Refrigeration Industries Company was established 40 years ago in 1973, by Amiri Decree. The company's operations began with the construction of the first cold stores in the region, to enable the storage of the imported foods, on which Kuwait relied. Along with the development and advancement of the country, so has RIC prospered and expanded, and is now a milestone in the history of modern Kuwait.

RIC takes pride in its successful record and the many accolades it has garnered over time, but the greatest achievement has been the provision of comfort and protection from the harsh climate, to the people of Kuwait.

More than 40 years of uninterrupted service, overcoming extreme weather conditions, war, economic recessions and ever increasing competition, is testimony to the fact that RIC has met the expectations and responsibilities that was envisioned at the beginning and also highlights the tenacity and vision to exceed them in the future.

Facts throughout the years

- 1973 Warehouses were established by Amiri Decree.
- 1979 RIC Constructed the Medical Cold Stores Complex, the world's largest at that time.
- 1980 RIC Air Conditioning manufacturing plant set up in Sulaihya.
- 1981 Production of Package & Mini-Split A/Cs started under York-Gulf.
- 1984 RIC was listed in Kuwait Stock Exchange.
- 1986 COOLEX brand Production Launched.
- 1991 RIC rebuilt the manufacturing plant destroyed during the war.
- 1997 Achieved ISO Certification ISO 9001:1994.
- 2002 ETL Designed testing lab became fully operational.
- 2004 Privatization of RIC.
- 2010 COOLEX becomes the first A/C Unit to Pass MEW's new regulations.
- 2010 RIC Factory Renovation and Expansion into neighboring countries.
- 2012 Achieved UL & AHRI Certification for Coolex Units.
- 2014 Achieved SASO Certification for Concealed Ducted Split Series.
- 2014 Achieved EUROVENT Certification for Air Handling Units AHU.
- 2014 Achieved UL Certification for Air Cooled Chillers.

نبذة عن الشركة

شركة صناعات التبريد (متداولة في سوق الكويت للأوراق المالية برقم 504) هي شركة متنوعة الأنشطة تعمل في مجال التصنيع والمقاولات والخدمات. ونحن نقدم مجموعة كبيرة من المنتجات والخدمات والحلول التقنية في مجال مواجهة الظروف المناخية وحلول التخزين. وقد حازت الشركة على إعراف إقليمي بقدراتها الهندسية وكفاءتها الإدارية.

شركة صناعات التبريد هي مجموعة شركات تهدف إلى توفير أعلى مستويات الجودة من حيث المنتجات والخدمات التي تلبى احتياجات عملائها السكنية والتجارية. وعلى مدى أربعين عاماً مضت على إنشاء شركتنا فقد إستطلعنا أن نوطد أقدامنا في جميع قطاعات السوق الكويتي. ونحن إذ نفتخر بالإنجازات التي حققناها، إلا أننا أشد فخرًا بأننا تمكنا من الوقوف إلى جانب أهل الكويت على مدى سنوات طويلة في مواجهة تقلبات الظروف المناخية القاسية سواء من حيث درجات الحرارة العالية أو الأتربة أو الرطوبة.

وباعتبارها إحدى الشركات الصناعية العاملة في دولة الكويت، فقد واجهت الشركة تحديات وأمال كبيرة في سعيها لتحقيق النجاح، وقد كانت الشركة - ولا تزال - معلماً من المعالم المهمة في نظر أهل الكويت لما قدمته من منتجات وخدمات إستطاعت أن تغير الطبيعة القاسية لمناخ الكويت. فبعد نحو 40 عاماً تقريباً، لا يزال السؤال مطروحا حول تحقيقنا لهذه التوقعات، فهل إستطاعت الشركة أن تتحمل مسؤولياتها على الوجه الأكمل؟ ويأتي الرد بالإيجاب، فعلى مدى أربعين عاماً تقريباً لم تتوقف الشركة خلالها عن الإستمرار في تقديم خدماتها وأعمالها رغم الصعوبات التي تمثلت في ظروف الطقس القاسية أو الحروب أو الكساد الاقتصادي أو إرتفاع حدة المنافسة، فقد كانت كل واحدة من هذه الظروف بمثابة شهادة على أننا حققنا ما وعدنا به وما عقدنا العزم على تنفيذه.

حقائق وتواريخ

- 1973 تم إنشاء المستودعات بناء على مرسوم أميري.
- 1979 عهدت وزارة الصحة الكويتية لشركة صناعات التبريد بإنشاء مجمع مستودعات مخازن التبريد الطبية، وقد كان هذا المجمع حينها هو الأضخم من نوعه على مستوى العالم، وقد وصلت تكلفته إلى 12.000.000 دينار كويتي.
- 1980 تم إنشاء مصنع مكيفات الهواء التابع لشركة صناعات التبريد في الصليبية.
- 1981 بدء إنتاج أجهزة التكييف المدمجة والمنفصلة الصغيرة تحت علامة York-Gulf.
- 1984 تم قيد شركة صناعات التبريد في سوق الكويت للأوراق المالية.
- 1986 بدء إنتاج مكيفات علامة كولكس.
- 1991 قامت شركة صناعات التبريد بإعادة بناء مصنعها الذي دمرته الحرب.
- 1997 الحصول على شهادة الأيزو 9001:1994.
- 2002 بدء تشغيل مختبر فحص وحدات التكييف (ETL).
- 2004 خصخصة شركة صناعات التبريد.
- 2010 كانت وحدات كولكس أول وحدات تكييف هواء تجتاز اللوائح التي أقرتها (وزارة الكهرباء والماء).
- 2010 تم تجديد مصنع شركة صناعات التبريد وبدء التوسع والتصدير إلى الدول المجاورة.
- 2012 الحصول على شهادة UL و AHRI لأجهزة التكييف كولكس.
- 2014 الحصول على شهادة SASO لأجهزة التكييف المنفصلة.
- 2014 الحصول على شهادة EUROVENT لأجهزة مناولة الهواء.
- 2014 الحصول على شهادة UL لمبردات الهواء الشيلير.

NOTES

Coollex Distributors

United Arab Emirates UAE

Obaid Humaid Al-Tayer Engineering Division Al Tayer Group

Address: Dubai – UAE, PO Box 2623
Tel : +971 4 2011272
Fax : +971 4 2825008
Mobile : +971 50 3500747
Email : bkrishnan@altayer-eng.com
Website: www.altayer.com

Kingdom of Saudi Arabia KSA

Al-Etmad for Refrigeration and Air Conditioning Industries Company

Address: Al Qortobah Quartier, King Abdullah Road
Riyadh – KSA, P.O. Box 50467 Riyadh 11533
Tel : + 966 11 4958004
Fax : + 966 11 4958812
Mobile : + 966 920022181
Email : abunaif722@ksacoollex.com
Website: www.Coollex.co

Republic of Iraq

SWEER Company Limited

Address: Al Senak -Jumhuria Street - Baghdad-Iraq
P.O. Box: 8095
Tel : +964 1 8181196
Mobile : +964 7705 884444
Email : sweerco@yahoo.com
Website: www.sweerco.com

State of Qatar

Darwish Trading Company W.L.L

Address: P.O.Box 92 Doha - Qatar
Direct : +974 4468 3951
Tel : +974 4468 3950
Fax : +974 4468 5681
Email : acvr@darwish-tdg.qa
Email : dtcaircondi@darwish-tdg.qa
Website: http://www.darwish-trading.com

Sultanate of Oman

Al Noor Projects Engineering & Trading Company

Address: Third Floor, Oman House
P.O. Box: 1047, P.C: 114 Hay Al Mina - Muscat
Tel : +968 24709402/403
Fax : +968 24709401
Email : info@alnoorprojects.com
Email : gm@alnoorprojects.com
Website: www.alnoorprojects.com

Kingdom of Bahrain

Y.K. Almoayyed & Sons

Address: EHAD – Project Department, Sehla Workshop
P.O. Box 143, Manama, Kingdom of Bahrain
Tel : +973 17 400 444, Extn. 205
Direct : +973 17 405 250
Fax : +973 17 400 388
Email : Pradeep@almoayyed.com.bh
Email : ac@almoayyedcg.com
Website: www.almoayyed.com

Turkey

CS GROUP

Address : Küçükyalı, Altintepe Mah.
Galipbey Cad. CS Plaza,
No: 127 34840 Maltepe-Istanbul Turkey
Tel : +90 216 388 85 50
Fax : +90 216 388 86 90
Call Center: +90 444 44 91
Email : info@csgroup.com.tr
Website : www.csgroup.com.tr

Iran

Capital ICEBERG Limited Company

Address: No. 31, 3rd Floor, Aghdasieyeh Trade Center
Aghdasieyeh Street. Tehran – Iran
Tel : +98 (021) 26110510
Fax : +98 (021) 26110510
Mobile : +98 912 119 2961
Email : info@capitaliceberg.com
Email : saeed.s@capitaliceberg.com
Email : sara.s@capitaliceberg.com
Website: www.capitaliceberg.com

Please contact Sales and Marketing Department
sales@ric.com.kw or www.coollex.com.kw for
specific information on the current design and
specifications. **Ref no.: CSCH-15-5-000**

CENTRAL AIR CONDITIONING AND SPLIT UNIT
Coollex continuously works towards the improvement of
its products. Hence, the design and specifications of the
ordered product may vary without prior notice.

www.cooler.com.kw

