



Product Catalogue

MTZ Rooftop Unit
R410A, 50 & 60Hz
Cooling Only



May 2015

RT-SVM003A-EN



Contents

01. Product Lineup.....	04
02. External Appearance	05
03. Nomenclature	06
04. Features	07
05. Specification.....	10
06. Dimensional Drawing	13
07. Wiring Diagram.....	18
08. Performance Data	28
09. Electrical Data	38
10. Fan performance data	39
11. Refrigerant Cycle Diagram	50
12. Operation Limit	52
13. Installation	53
14. Wired Controller	56
15. Error Code	61
16. Accessory	70
17. Maintenance and Upkeep.....	70
Appendix	71
Mechanical Specification	74



1. Product Lineup

Tropical application

Capacity	Function	Trane Model	Power Supply	Air Flow Configuration
6.2Ton	Cooling only	MTZH075DC00300A	380~415V / 3 / 50Hz	Horizontal Flow
7.5Ton	Cooling only	MTZH090DC00300A	380~415V / 3 / 50Hz	Horizontal Flow
8.5Ton	Cooling only	MTZH102DC00300A	380~415V / 3 / 50Hz	Horizontal Flow
10Ton	Cooling only	MTZH120DC00300A	380~415V / 3 / 50Hz	Horizontal Flow
12.5Ton	Cooling only	MTZH150DC00300A	380~415V / 3 / 50Hz	Horizontal Flow
15Ton	Cooling only	MTZH180DC00300A	380~415V / 3 / 50Hz	Horizontal Flow
17.5Ton	Cooling only	MTZH210DC00300A	380~415V / 3 / 50Hz	Horizontal Flow
20Ton	Cooling only	MTZH240DC00300A	380~415V / 3 / 50Hz	Horizontal Flow
25Ton	Cooling only	MTZH300DC00300A	380~415V / 3 / 50Hz	Horizontal Flow
30Ton	Cooling only	MTZH360DC00300A	380~415V / 3 / 50Hz	Horizontal Flow

Note: Please refer to specification tables for accurate cooling or heating capacity with Kw or Btu/h unit.

2. External Appearance



6.2&7.5Ton



8.5&10Ton



12.5&15Ton



17.5&20Ton



25&30Ton

3. Nomenclature

M	TZ	H	075	D	C	0	0	3	0	0	A
1	2,3	4	5,6,7	8	9	10	11	12	12	14	15

Digit #1	=	Family (M)	Digit #9	=	Product design sequence
-----------------	---	-------------------	-----------------	---	--------------------------------

Digit #2,3	=	Product type	Digit #10	=	Heating
		TZ	=	Cooling Only Units	0 = Cooling only

Digit #4	=	Airflow configuration	Digit #11	=	Anticorrosion protection
		C	=	Convertible on site	0 = Standard
		H	=	Horizontal Flow	1 = Anticorrosion protection on coil
		D	=	Down Flow	

Digit #5,6,7	=	Unit size (Nominal gross cooling capacity)	Digit #12	=	Product series
		075	=	6,2 tons	3 = T3 condition 52°C

		090	=	7,5 tons	Digit #13	=	Currently not used (0)
		102	=	8,5 tons	Digit #14	=	Currently not used (0)
		120	=	10 tons	Digit #15	=	Special
		150	=	12,5 tons			A: Minor Design Sequence
		180	=	15 tons			
		210	=	17,5 tons			
		240	=	20 tons			
		300	=	25 tons			
		360	=	30 tons			

Digit #8	=	Unit voltage
		D = 50Hz / 380 - 415V~, 3Ph.
		1 = 60Hz / 208 - 230V~, 1Ph.
		3 = 60Hz / 208 - 230V~, 3Ph.
		K = 60Hz / 380 - 415V~, 3Ph.
		C = 60HZ / 220V~,3Ph.

4. Features

4.1 High reliability and high efficiency

Outstanding reliability

- ◆ Trane rooftop package units shall be factory assembled, internally wired, fully charged refrigerant and 100% run tested to check cooling and heating operation, fan and blower rotation, and control sequence before leaving the factory. Wiring internal to the unit shall be colored and numbered for simplified identification. The unit is provided with an integral weather resistant control panel.
- ◆ Multiple self-protecting functions guarantee the safety of unit and running perfectly: high-pressure protection, low-pressure protection, over-heat protection, over-current protection and so on.

Reliable components

- ◆ Reliable brand compressor, high IP class motor, reliable pressure switch.



Excellent efficiency

- ◆ High efficiency scroll compressor;
- ◆ Enlarge the air inlet area space contribute a high efficiency.

Durable construction

- ◆ Pre-painted exterior cabinet panels pass 1000-hour Salt Spray Test for durability.
- ◆ Weather-resistant construction with capped seams and sloped top panels.
- ◆ G90 galvanized heavy gauge plate conforming to ASTM-A-653, Zinc content of galvanized plate is 275 g/m².



New fan duct design

- ◆ Optimized fan vane shape reduces pressure loss and improves heat exchange efficiency.

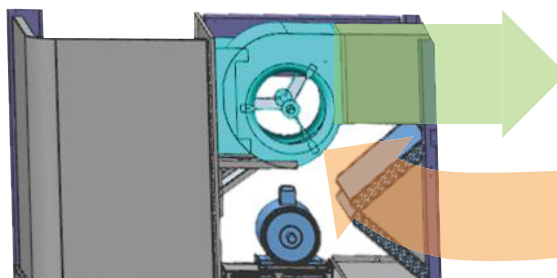

Adjustable Pulley

- ◆ Through changing the working pitch diameter of the pulley mounted on driver shaft, in turn the revolutions per minute of the driven shaft will increase or decrease to change air volume.



Advanced compressor control

- ◆ Compressor start-stop is controlled directly by the main control board. To prevent compressor start and stop frequently, when the unit first / re-power, the compressor will delay three minutes to start, when the indoor temperature is below the set temperature or mode conversion or system protection, the compressor will start after seven minutes delay.
- ◆ It has two-stage control for the system which has two compressors. The system will shut off one compressor in condition of part load.

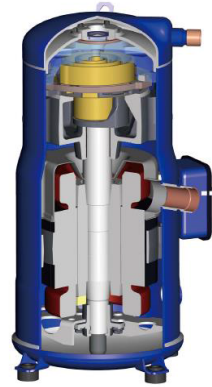

Compressor cycle duty operation

- ◆ When the set temperature and ambient temperature meet one compressor to start, for the first time to open compressor A, compressor B start next time, this extends the compressor's life span effectively.

4.2 Easy installation and service

Design flexibility, easy to install

- ◆ New structure design, compact design, smaller body size, better logistics cost
- ◆ Flexibility for downflow or horizontal flow

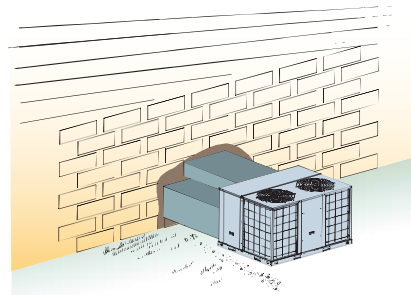
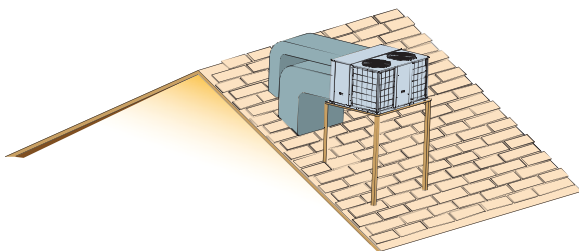

Easy drainage

- ◆ External drainage port reserved, quickly and accurately connect the rubber drainage pipe.



External pressure gauge ports

- ◆ The unit provide external pressure gauge ports, for convenient and fast checking without remove the panel.



✚ Easy access doors

- ◆ Installer no need to enter inside of the door, only out-of-doors.
- ◆ Provide easy access to system components for maintenance and service.
- ◆ Removable access doors on the filter, fan motor, and control box sections.

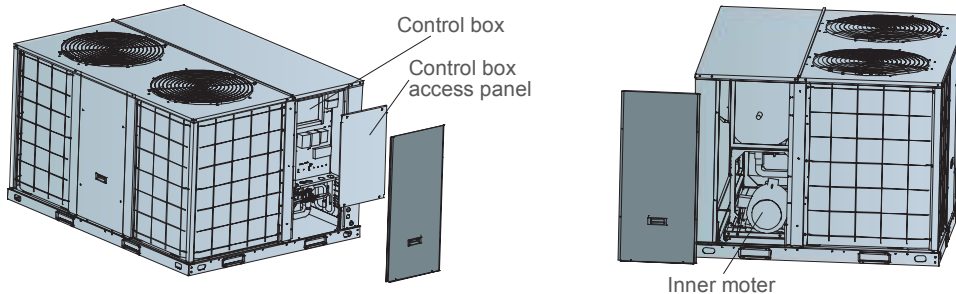

✚ Low voltage connections

- ◆ All ports of low voltage wires are integrated in the PCB board,so it is easy and safe for the installer to wire.

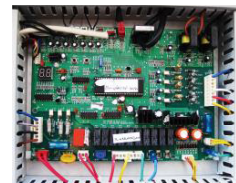

✚ System self-diagnostic

- ◆ The system self-diagnostic function, press the “check” button, the LED displays the normal checking code. When the unit is in running with abnormal operation, the LED will display the error code.

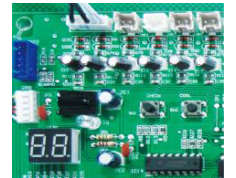

4.3 Standard features/options/accessories

Description	Standard features	Options (factory installed)	Accessories (field installed)
Horizontal discharge	◆		
Compressor crankcase heaters	◆		
Evaporator fan-belt driven	◆		
Evaporator fan motor-ODP type(TEFC type optional)	◆		
Condenser fan-direct drive, propeller type(Except 5ton)	◆		
Condenser fan-direct drive, axial type(Only 5ton)	◆		
Condenser fan motor-totally enclosed air-over type	◆		
Filter, Nylon		◆	
Filter, aluminum(Thickness 25mm)		◆	
Compressor overload protection	◆		
Low &high pressure switch	◆		
Cooling & heating thermostat	◆		
Condenser fan guard	◆		
Condenser coil guard	◆		
Wired controller KJR-12B	◆		
Wired controller KJR-23B			◆
Wired controller KJR-25B			◆
Drainage pipe			◆
Drainage outlet			◆
Snap ring			◆

5. Specifications

Tropical application

Nominal ton		(Ton)	6.2	7.5	8.5	10
Model			MTZH075DC00300A	MTZH090DC00300A	MTZH102DC00300A	MTZH120DC00300A
Power Supply		V,Ph,Hz	380~415V,3Ph,50Hz	380~415V,3Ph,50Hz	380~415V,3Ph,50Hz	380~415V,3Ph,50Hz
Cooling	Cooling Capacity (1)	Btu/h	75000	89000	103000	120000
		kW	22.0	26.0	30.0	35.0
	Power Input (1)	kW	6.5	7.7	9.0	10.5
	EER (1)	Btu/h/W	11.6	11.5	11.4	11.4
Cooling	Cooling Capacity (2)	Btu/h	61400	69600	80700	100200
		kW	18.0	20.4	23.7	29.4
	Power Input (2)	kW	7.7	8.7	10.1	12.5
	EER (2)	Btu/h/W	8.0	8.0	8.0	8.0
Max. input consumption		kW	9.0	12.5	14.8	17.8
Max. current		A	19.3	27.2	29.2	34.1
Performance	Indoor fan air flow	CFM	2800	2830	3500	4100
	ESP	Pa	80	80	80	90
Indoor Coil	Number of rows		4	3	4	4
	Fin spacing	mm	1.3	1.3	1.5	1.5
		FPI	19	19	17	17
	Tube diameter	mm	7	7	7	7
		inch	9/32	9/32	9/32	9/32
Indoor fan	Type		FC Centrifugal	FC Centrifugal	FC Centrifugal	FC Centrifugal
	Quantity		1	1	1	1
	Drive type		Direct	Direct	Belt	Belt
	Motor model		YDK750-4E	YDK750-4E	YE2-90L-4-1.5KW	YE2-90L-4-1.5KW
	Motors quantity		1	1	1	1
Compressor	Type		Scroll	Scroll	Scroll	Scroll
	Quantity		1	1	2/*1	2/*1
	Brand		Copeland	Danfoss	Hitachi/*Copland	Hitachi/*Copland
	Model		ZP72KCE-TFD-522	HCJ106T4LC6	E604DH-59D2G*2/ *ZP122KCE TFD 522	E654DH-65D2G*2/ * ZP144KCE-TFD-522
	Capacity	Btu/h	58345	89053	52784*2/*102000	58345*2/*120500
	Refrigerant oil charge	ml	1656	2400	1300x2/*2395	1300x2/*3134
Outdoor Coil	Number of rows		2.5	3	2.5	2.5
	Fin spacing	mm	1.5	1.5	1.5	1.5
		FPI	17	17	17	17
	Tube diameter	mm	7	7	7	7
		inch	9/32	9/32	9/32	9/32
Outdoor Fan	Type		Propeller	Propeller	Propeller	Propeller
	Quantity		1	1	1	1
	Drive type		Direct	Direct	Direct	Direct
	Motor model		YDK450-6C	YDK580-6C	YDK580-6C	YS1100-6P
	Motors quantity		1	1	1	1
Refrigerant	Type		R410A	R410A	R410A	R410A
	Refrigerant volume	kg	4	3.7	2.25+2.25/*4.2	2.3+2.3/*4.2
	Refrigerant Control		Piston	Piston	Piston	Piston
Net Weight		kg	223	231	331/*302	335/*323
Gross Weight		kg	228	236	342/*313	346/*335
Net Dimension	WxHxD	mm	1475x840x1130	1475x840x1130	1483x1138x1231	1483x1138x1231
Packing	WxHxD	mm	1497x867x1152	1497x867x1152	1492x1248x1146	1492x1248x1146
Shipping	Qty/Per 20'/40'/40'HQ		12/24/48	12/24/48	8/16/32	8/16/32

Note: The data are based on the following conditions:

Cooling: (1): Indoor Temperature 26.7°C(80°F) DB / 19.4°C(67°F) WB; - Outdoor Temperature 35°C(95°F) DB.

(2): Indoor Temperature 26.7°C(80°F) DB / 19.4°C(67°F) WB; - Outdoor Temperature 46°C(115°F) DB.



Nominal ton		(Ton)	12.5	15	17.5
Model			MTZH150DC00300A	MTZH180DC00300A	MTZH210DC00300A
Power Supply		V,Ph,Hz	380~415V,3Ph,50Hz	380~415V,3Ph,50Hz	380~415V,3Ph,50Hz
Cooling	Cooling Capacity (1)	Btu/h	150000	180000	208000
		kW	43.0	53.0	61.0
	Power Input (1)	kW	13.0	15.9	18.6
	EER (1)	Btu/h/W	11.5	11.3	11.2
Cooling	Cooling Capacity (2)	Btu/h	125400	146000	184000
		kW	36.8	42.8	53.9
	Power Input (2)	kW	15.9	18.5	22.8
	EER (2)	Btu/h/W	7.9	7.9	8.1
Max. input consumption		kW	21.0	25.0	28.6
Max. current		A	41.2	48	55
Performance	Indoor fan air flow	CFM	5500	7000	7600
	ESP	Pa	110	110	110
Indoor Coil	Number of rows		4	4	3
	Fin spacing	mm	1.3	1.3	1.3
		FPI	19	19	19
	Tube diameter	mm	7	7	7
inch		9/32	9/32	9/32	
Indoor fan	Type		FC Centrifugal	FC Centrifugal	FC Centrifugal
	Quantity		1	1	1
	Drive type		Belt	Belt	Belt
	Motor model		YE2-100L2-4-3KW	YE2-112M-4-4KW	YE2-112M-4-4KW
	Motors quantity		1	1	1
Compressor	Type		Scroll	Scroll	Scroll
	Quantity		2	2	2
	Brand		Copeland	Copeland	Copeland
	Model		ZP61KCE-TFD-522+ ZP122KCE-TFD-522	ZP61KCE-TFD-522+ ZP144KCE-TFD-522	ZP122KCE-TFD-522x2
	Capacity	Btu/h	49986+102018	49986+120500	102018x2
	Refrigerant oil charge	ml	1656+2513	1656+3253	2513x2
Outdoor Coil	Number of rows		3	3.5	2.5
	Fin spacing	mm	1.5	1.6	1.5
		FPI	17	16	17
	Tube diameter	mm	7	8	7
inch		9/32	5/16	9/32	
Outdoor Fan	Type		Propeller	Propeller	Propeller
	Quantity		1	1	2
	Drive type		Direct	Direct	Direct
	Motor model		YDK550-6E	YS1100-6	YDK550-6E
	Motors quantity		1	1	2
Refrigerant	Type		R410A	R410A	R410A
	Refrigerant volume	kg	1.7+2.8	2.25+3.9	3.7+3.7
	Refrigerant Control		Piston	Piston	Piston
Net Weight		kg	433	470	590
Gross Weight		kg	453	490	620
Net Dimension	WxHxD	mm	1965x1230x1130	1965x1230x1130	2192x1247x1670
Packing	WxHxD	mm	1990x1260x1140	1990x1260x1140	2212x1284x1695
Shipping	Qty/Per 20'/40'/40'HQ		6/12/24	6/12/24	3/7/14

Note:

The data are based on the following conditions:

Cooling: (1): Indoor Temperature 26.7°C(80°F) DB / 19.4°C(67°F) WB; - Outdoor Temperature 35°C(95°F) DB.
 (2): Indoor Temperature 26.7°C(80°F) DB / 19.4°C(67°F) WB; - Outdoor Temperature 46°C(115°F) DB.



Nominal ton		(Ton)	20	25	30
Model			MTZH240DC00300A	MTZH300DC00300A	MTZH360DC00300A
Power Supply		V,Ph,Hz	380~415V,3Ph,50Hz	380~415V,3Ph,50Hz	380~415V,3Ph,50Hz
Cooling	Cooling Capacity (1)	Btu/h	240000	300000	360000
		kW	70.0	87.0	105.0
	Power Input (1)	kW	21.6	27.5	33.3
	EER (1)	Btu/h/W	11.1	10.9	10.8
Cooling	Cooling Capacity (2)	Btu/h	199800	251700	336300
		kW	58.6	73.8	98.6
	Power Input (2)	kW	25.1	32.4	42.6
	EER (2)	Btu/h/W	8.0	7.8	7.9
Max. input consumption		kW	34.0	42.0	49.0
Max. current		A	66.9	77.4	94.1
Performance	Indoor fan air flow	CFM	8800	10000	12000
	ESP	Pa	120	130	270
Indoor Coil	Number of rows		4	4	4
	Fin spacing	mm	1.3	1.6	1.6
		FPI	19	16	16
	Tube diameter	mm	7	8	8
inch		9/32	5/16	5/16	
Indoor fan	Type		FC Centrifugal	FC Centrifugal	FC Centrifugal
	Quantity		1	1	1
	Drive type		Belt	Belt	Belt
	Motor model		YE2-132S-4-5.5KW	YE2-132M-4-7.5KW	YE2-132M-4-7.5KW
	Motors quantity		1	1	1
Compressor	Type		Scroll	Scroll	Scroll
	Quantity		2	2	2
	Brand		Copeland	Danfoss	Danfoss
	Model		ZP144KCE-TFD-522x2	SH161A4ALCx2	SH184A4ALCx2
	Capacity	Btu/h	120500x2	132386x2	152383x2
	Refrigerant oil charge	ml	3253x2	3300x2	3600x2
Outdoor Coil	Number of rows		3	3+2	3+3
	Fin spacing	mm	1.5	1.5	1.5
		FPI	17	17	17
	Tube diameter	mm	7	7	7
inch		9/32	9/32	9/32	
Outdoor Fan	Type		Propeller	Propeller	Propeller
	Quantity		2	2	2
	Drive type		Direct	Direct	Direct
	Motor model		YS1100-6-3	YS1500-6-2	YS1500-6-2
	Motors quantity		2	2	2
Refrigerant	Type		R410A	R410A	R410A
	Refrigerant volume	kg	5.65+5.65	6.0+6.0	7.6+7.6
	Refrigerant Control		Piston	Capillary	Capillary
Net Weight		kg	670	895	910
Gross Weight		kg	700	925	940
Net Dimension	WxHxD	mm	2192x1247x1670	2220x1245x2320	2220x1245x2320
Packing	WxHxD	mm	2212x1284x1695	2230x1275x2330	2230x1275x2330
Shipping	Qty'Per 20'/40'/40'HQ		3/7/14	2/5/10	2/5/10

Note:

The data are based on the following conditions:

Cooling: (1): Indoor Temperature 26.7°C(80°F) DB / 19.4°C(67°F) WB; - Outdoor Temperature 35°C(95°F) DB.

(2): Indoor Temperature 26.7°C(80°F) DB / 19.4°C(67°F) WB; - Outdoor Temperature 46°C(115°F) DB.

6. Dimensional Drawings

6.1 6.2&7.5ton

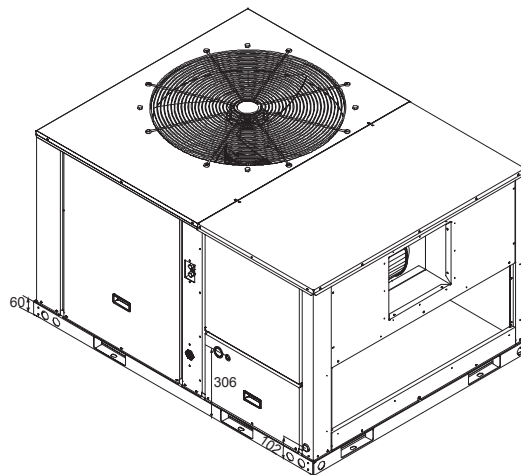
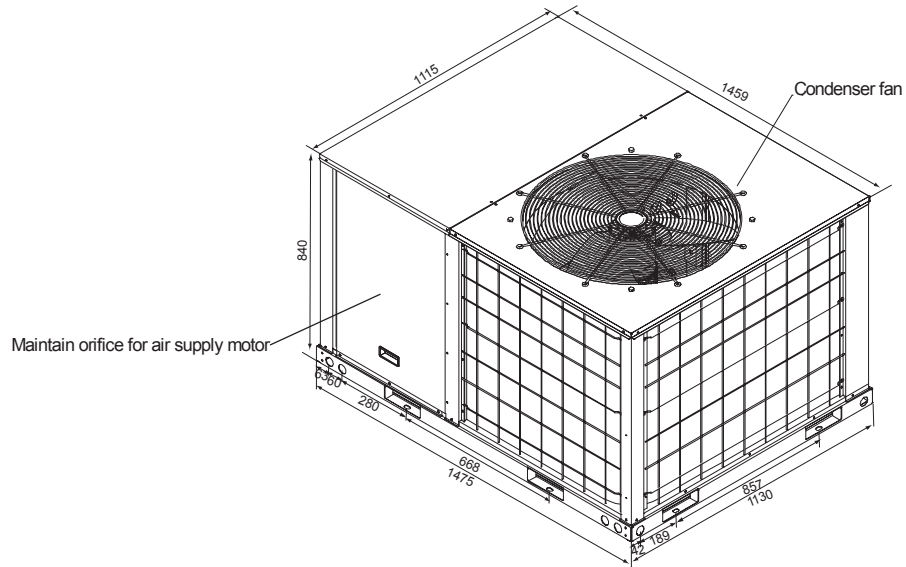

Hole for bottom installation
8-15x20

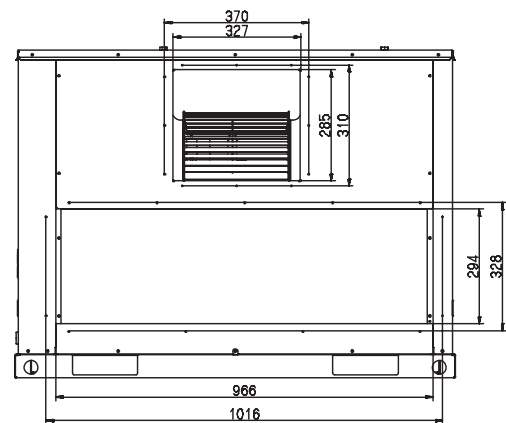
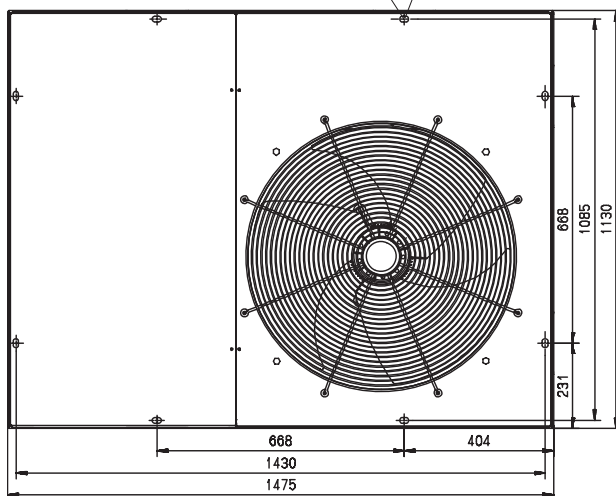

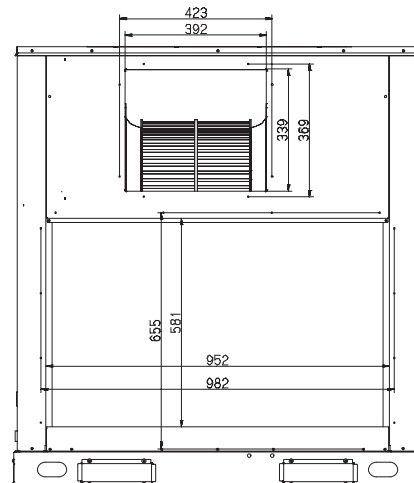
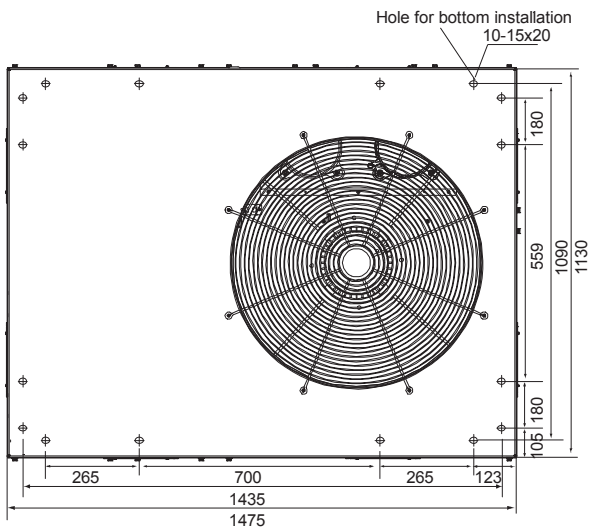
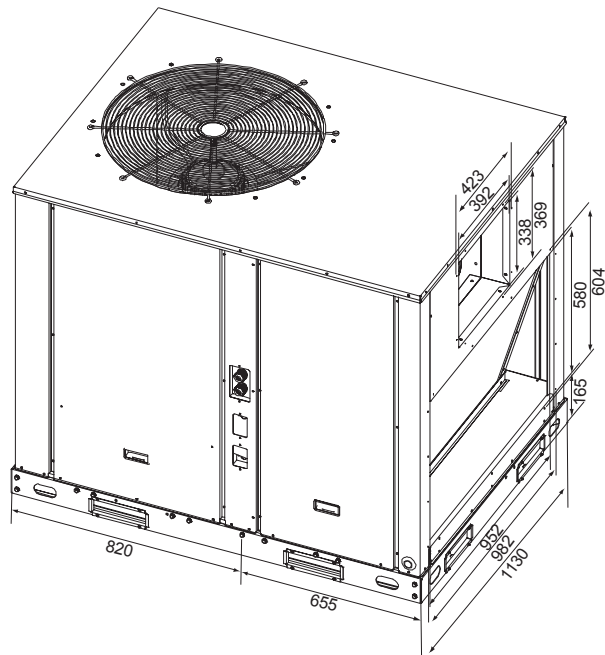
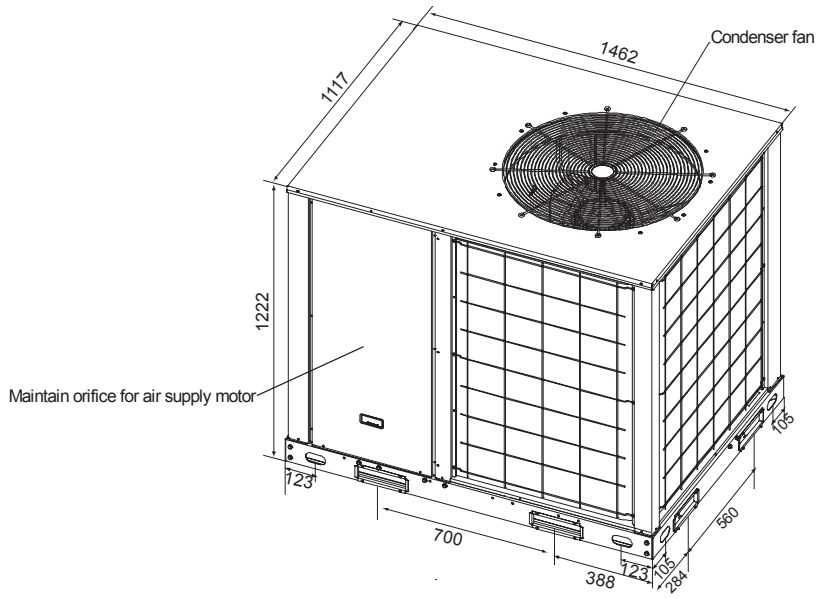
6.2 8.5&10ton

6.3 12.5&15ton

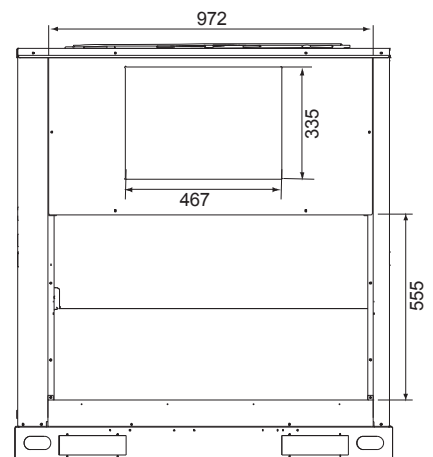
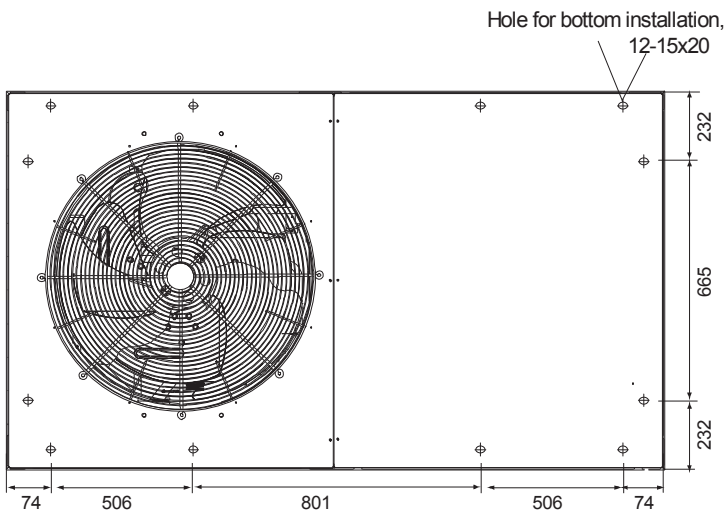
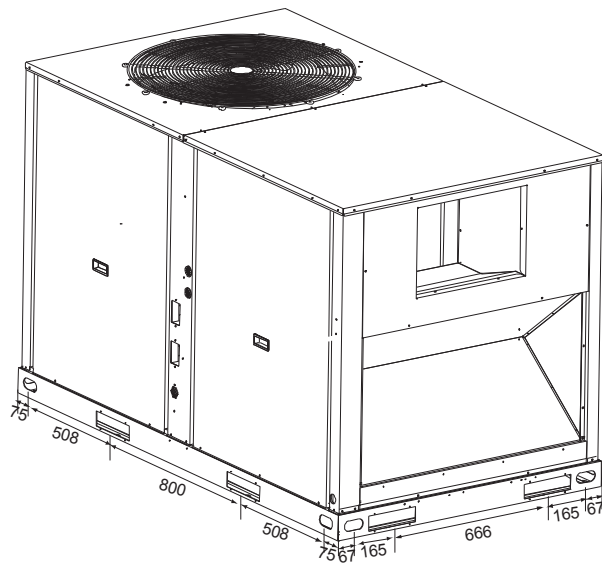
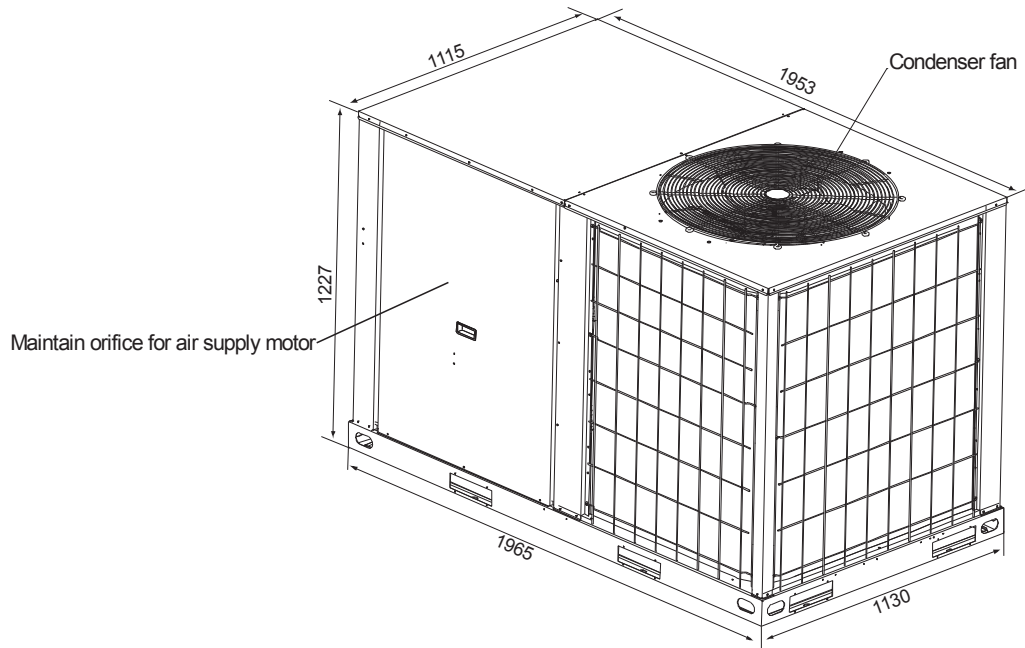

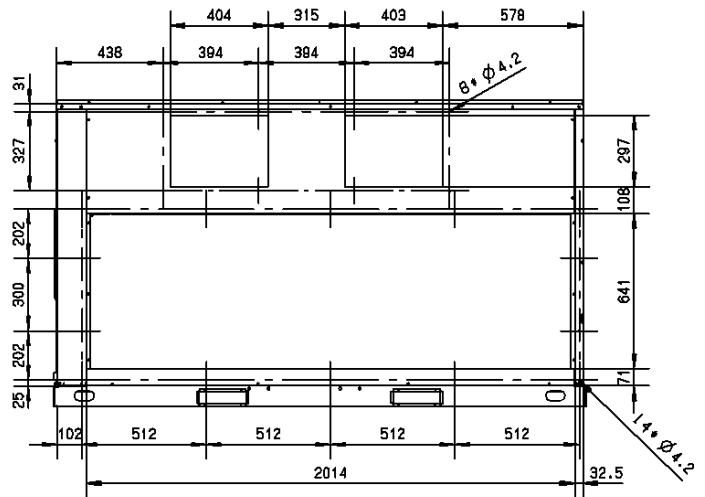
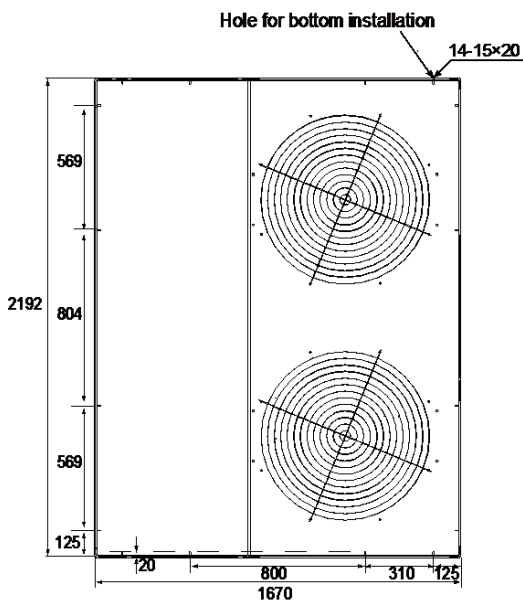
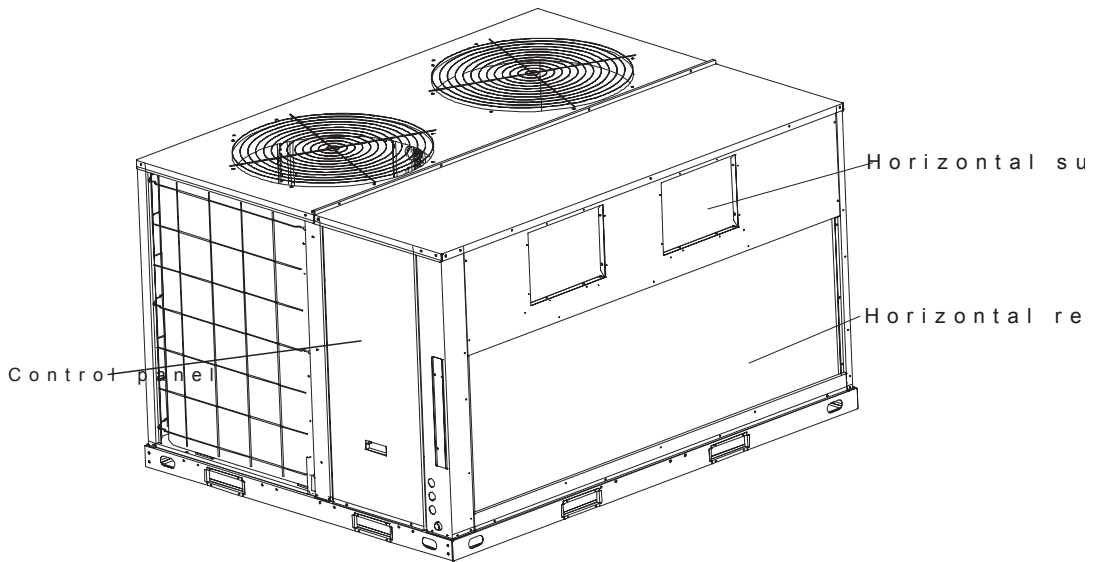
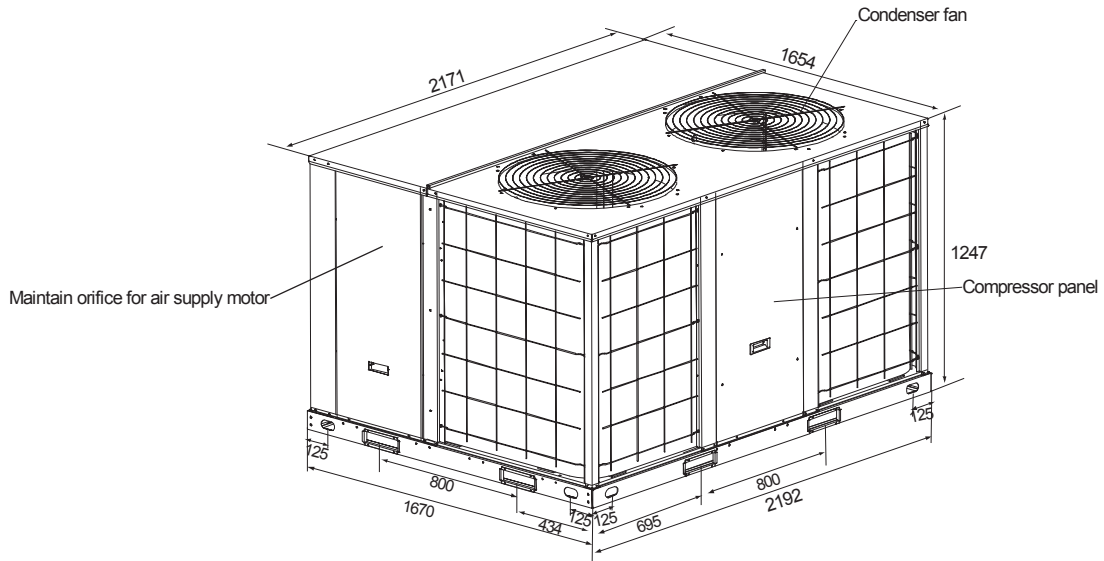
6.4 17.5&20on

6.5 25&30ton

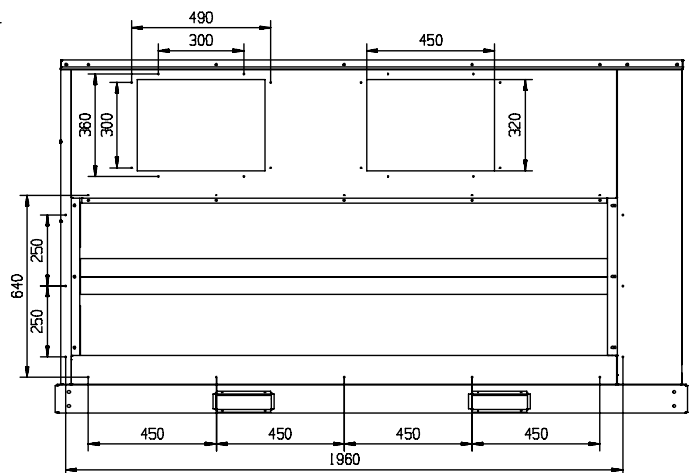
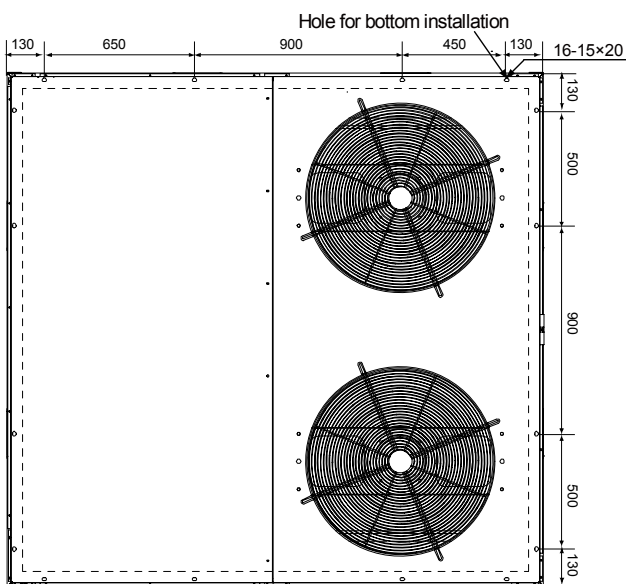
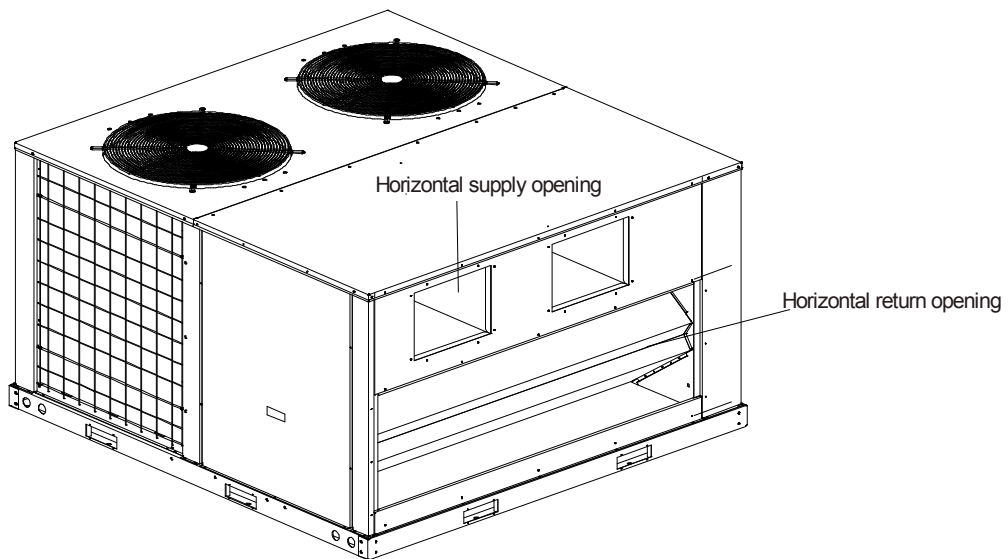
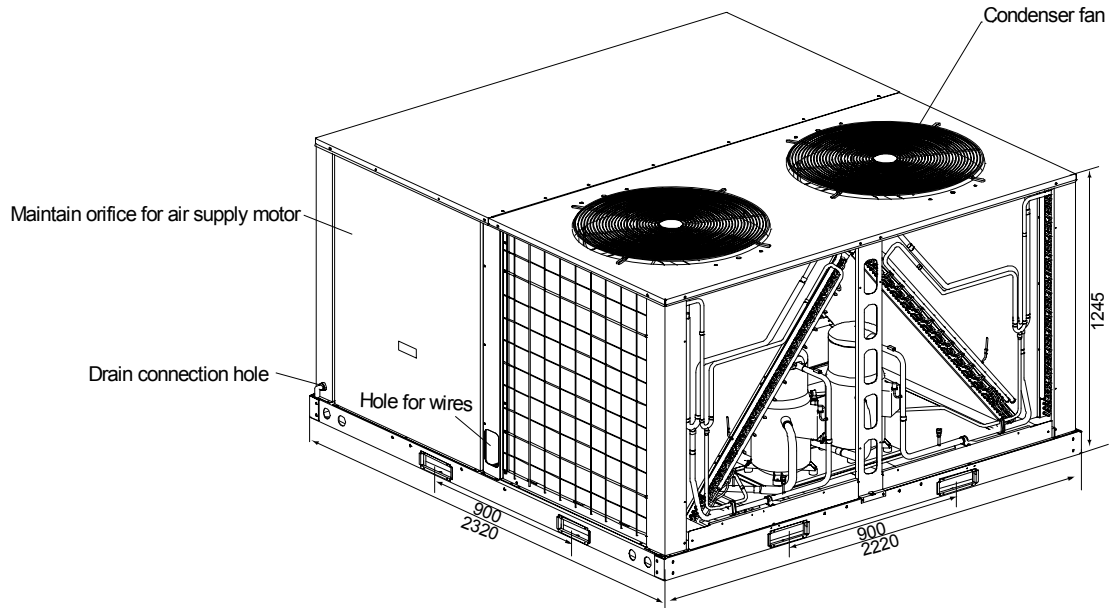



7. Wiring Diagrams

Tropical application

7.1 MTZH075DC00300A

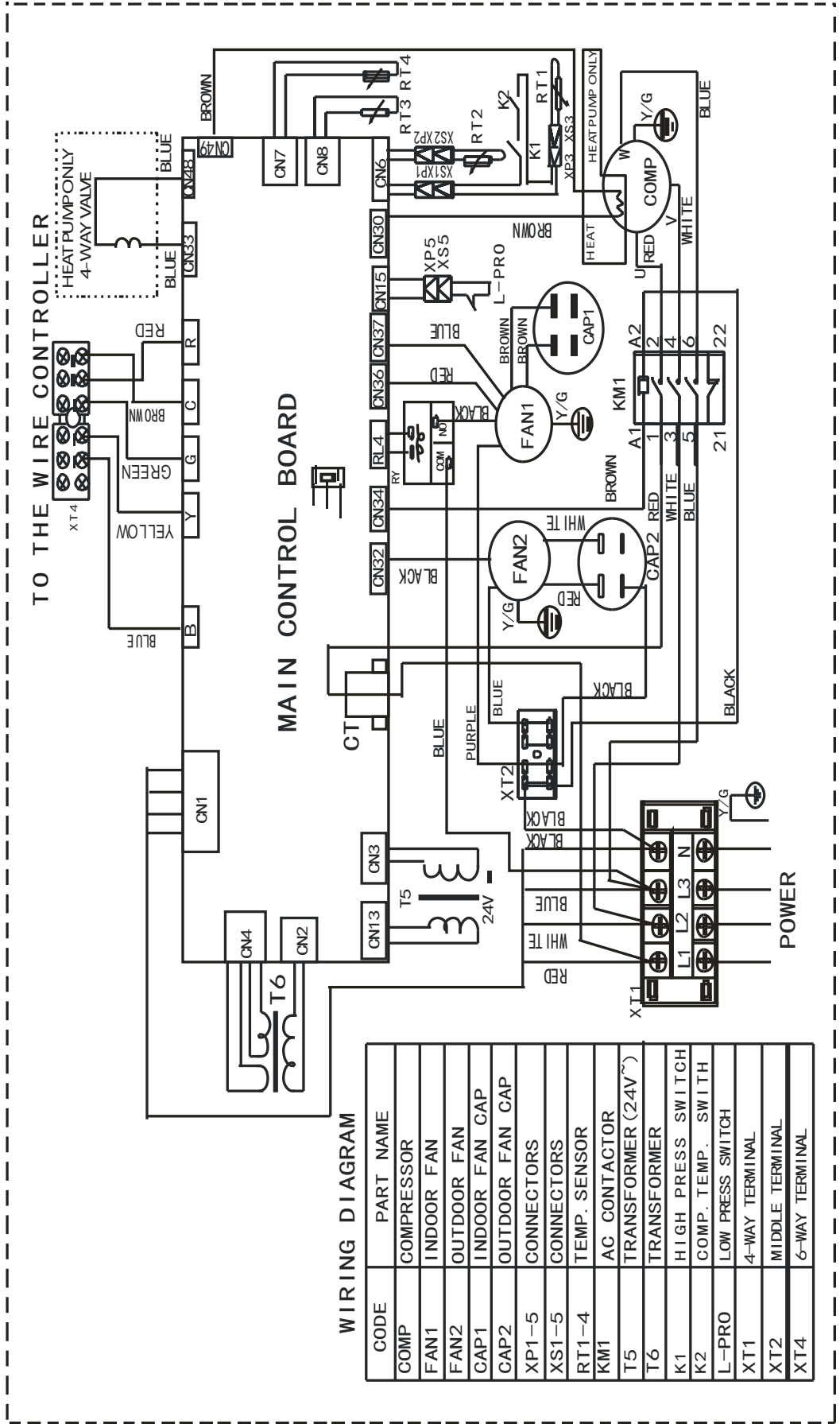

7.2 MTZH090DC00300A

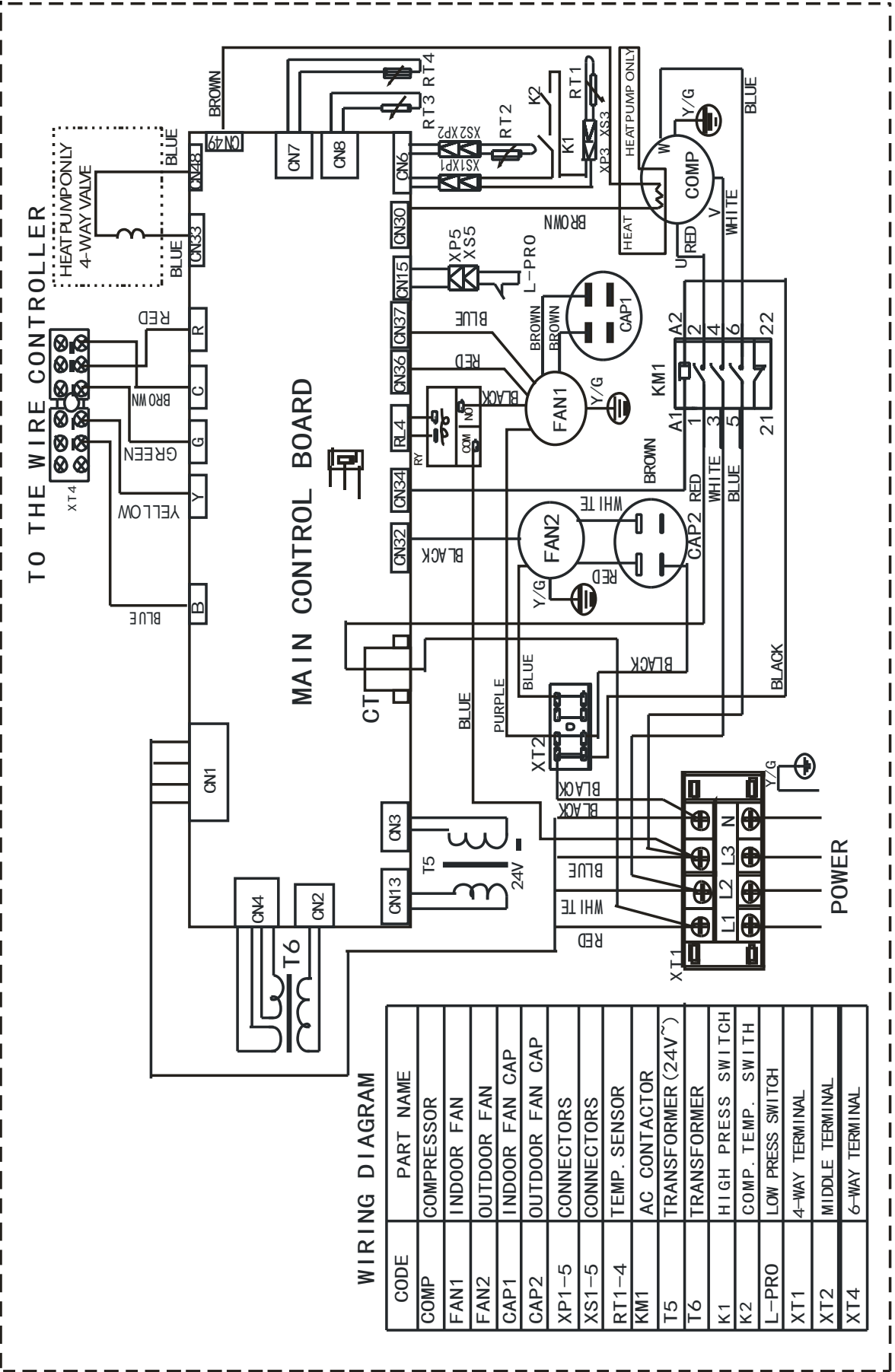



TRANE

7.3 MTZH102DC00300A

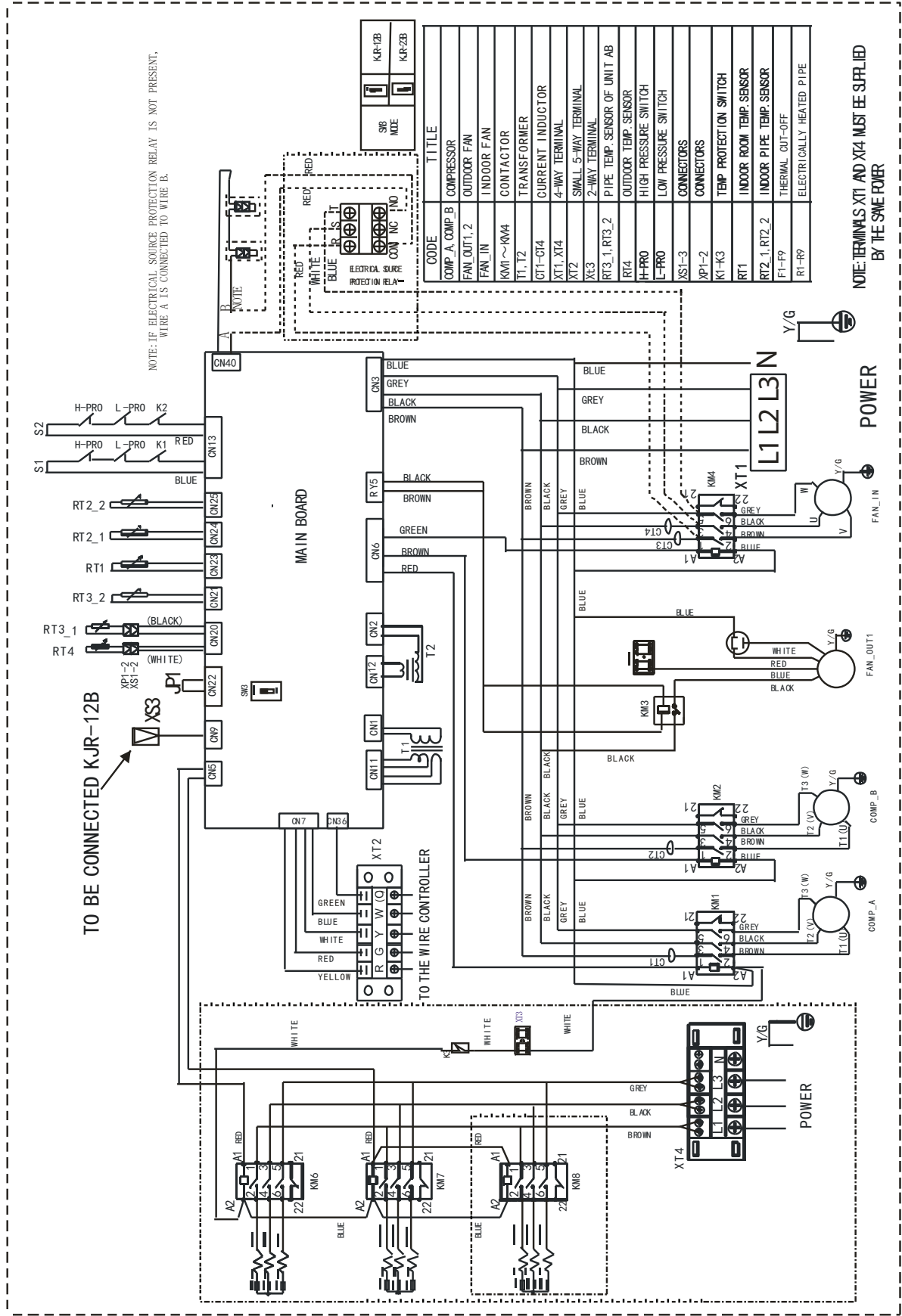

CODE	TITLE
COMP_A, COMP_B	COMPRESSOR
FAN_OUT1, 2	OUTDOOR FAN
FAN_IN	INDOOR FAN
KM1~KM4	CONTACTOR
T1, T2	TRANSFORMER
CT1-CT4	CURRENT INDUCTOR
XT1, XT4	4-WAY TERMINAL
XT2	SMALL 5-WAY TERMINAL
XT3	2-WAY TERMINAL
RT3_1, RT3_2	PIPE TEMP. SENSOR OF UNIT AB
RT4	OUTDOOR TEMP. SENSOR
H-PRO	HIGH PRESSURE SWITCH
L-PRO	LOW PRESSURE SWITCH
XPS1-3	CONNECTORS
XP1-2	CONNECTORS
K1-K3	TEMP PROTECTION SWITCH
RT1	INDOOR ROOM TEMP. SENSOR
RT2_1, RT2_2	INDOOR PIPE TEMP. SENSOR
F1-F9	THERMAL CUT-OFF
R1-R9	ELECTRICALLY HEATED PIPE

NOTE: TERMINALS XT1 AND XT4 MUST BE SUPPLIED BY THE SAME POWER

NOTE: IF ELECTRICAL SOURCE PROTECTION RELAY IS NOT PRESENT, WIRE A IS CONNECTED TO WIRE B.



7.4 MTZH120DC00300A

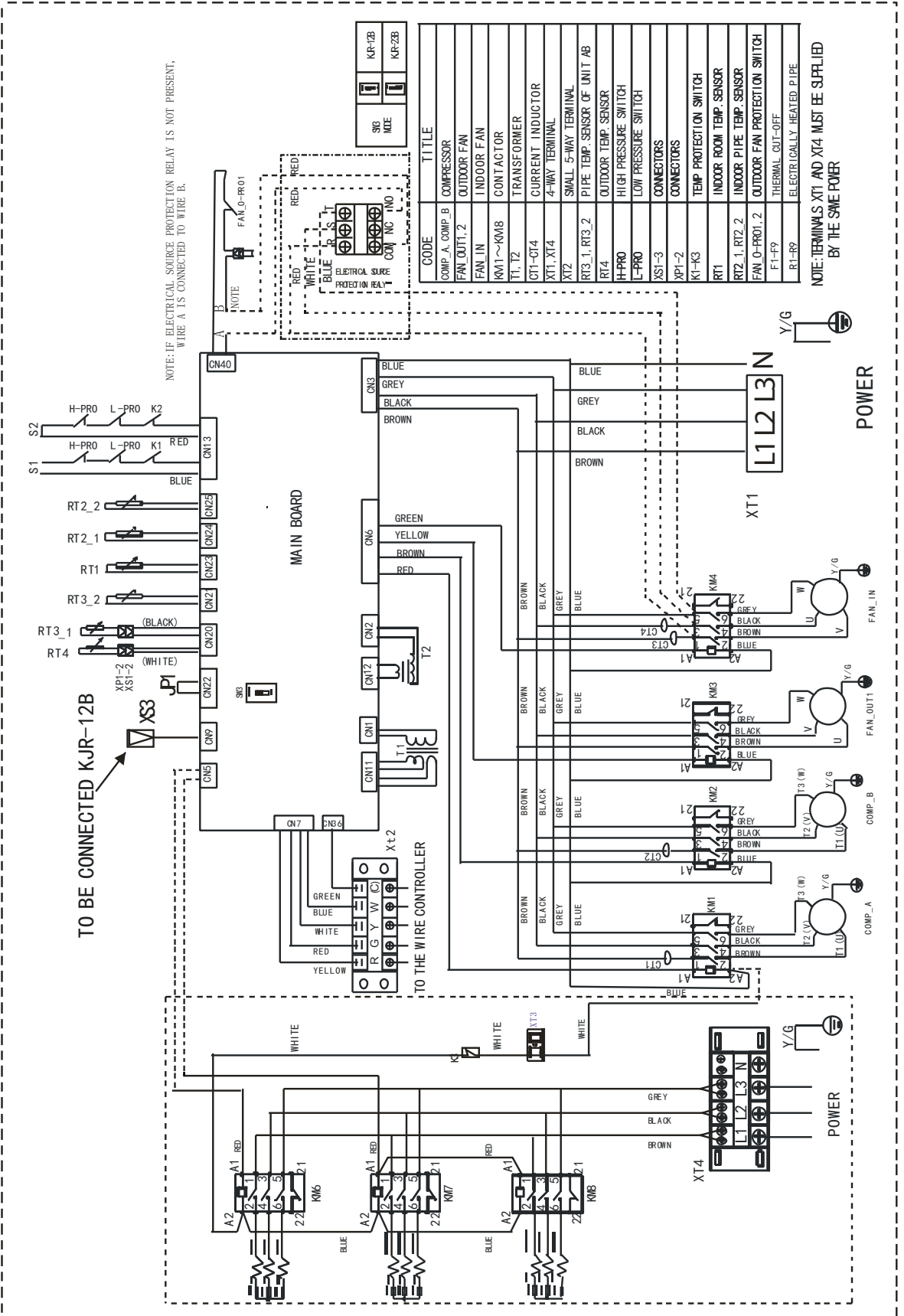



TRANE®

7.5 MTZH150DC00300A

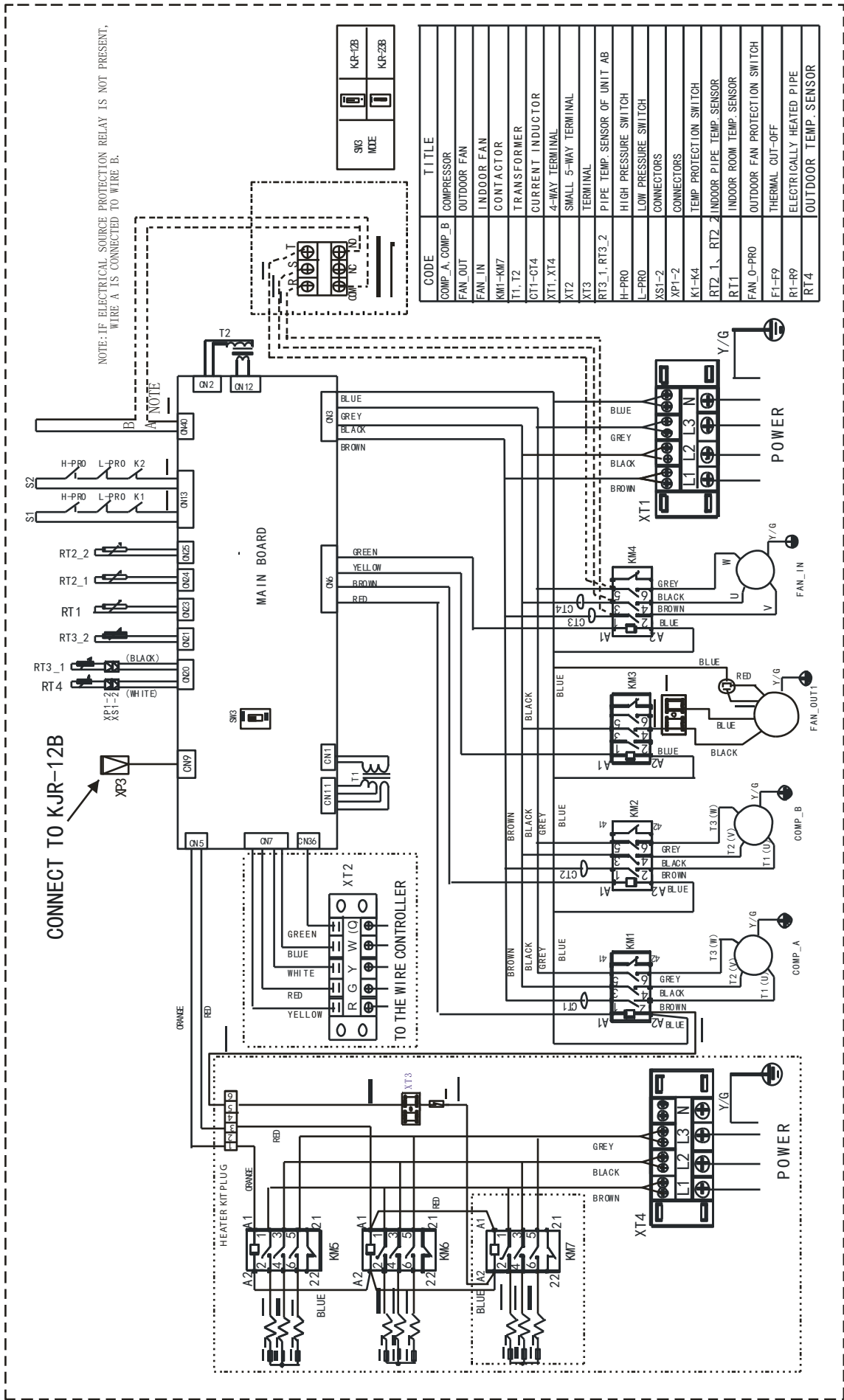

7.6 MTZH180DC00300A

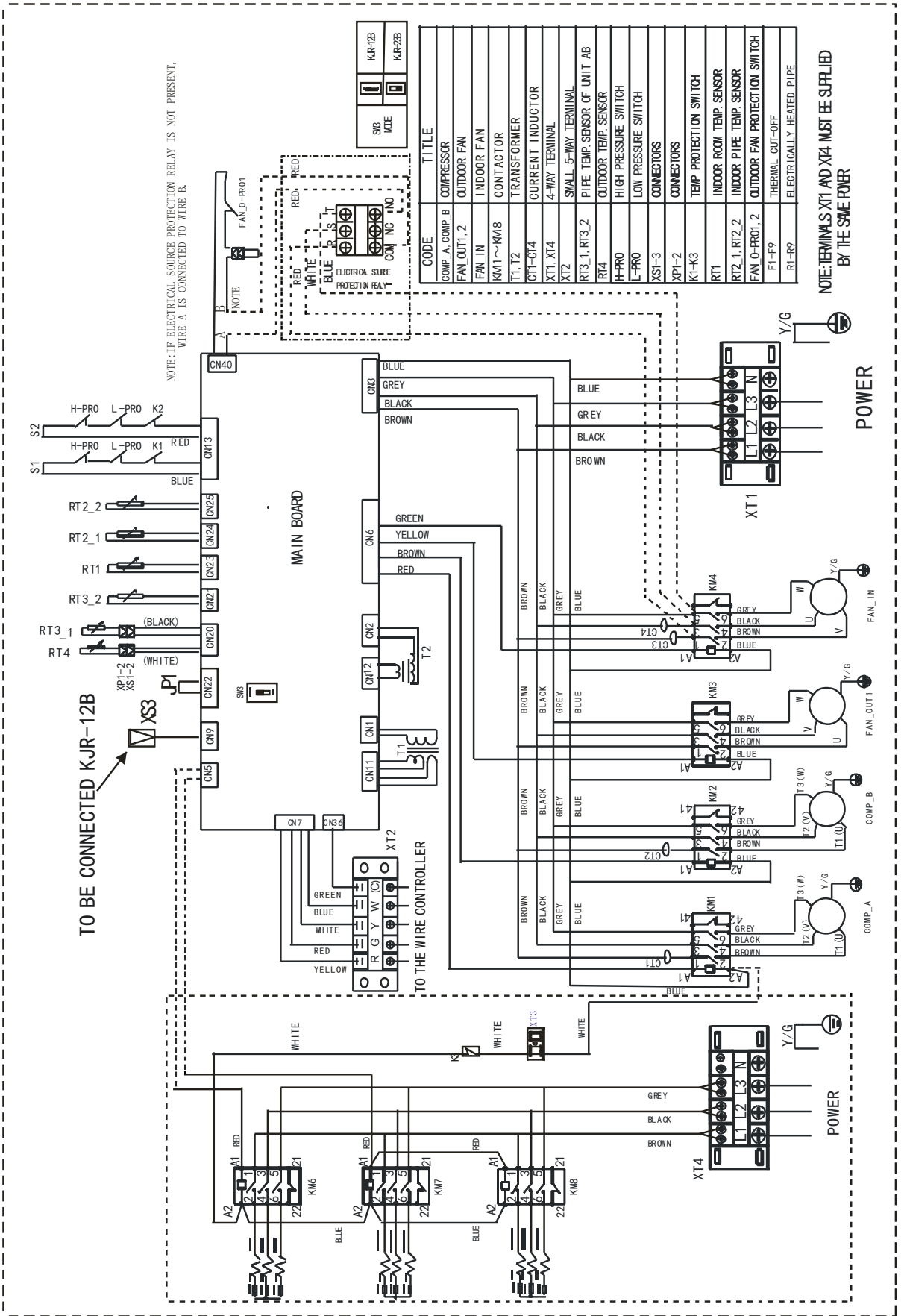



TRANE

7.7 MTZH210DC00300A

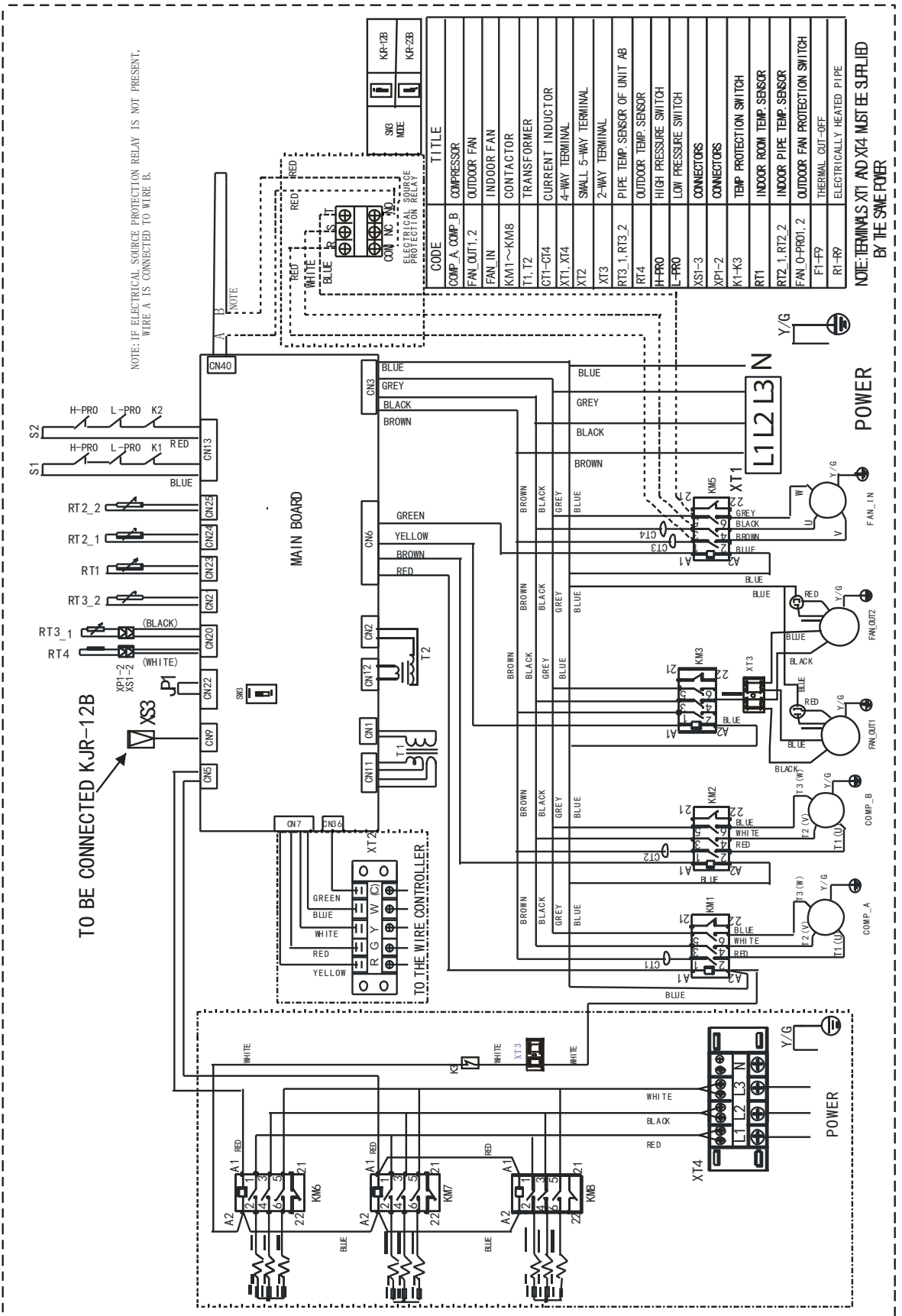



7.8 MTZH240DC00300A

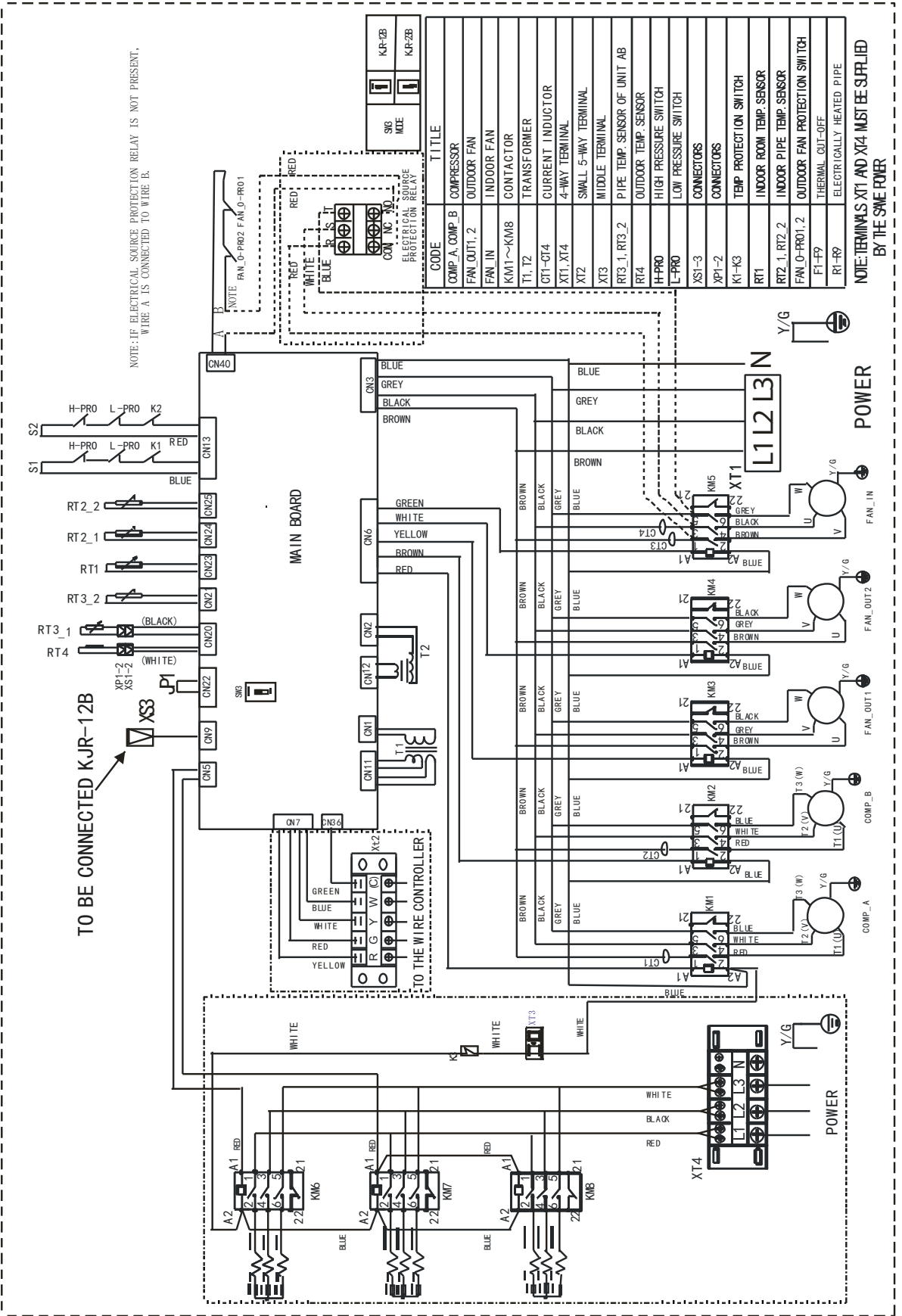



TRANE®

7.9 MTZH300DC00300A

TO BE CONNECTED KJR-12B

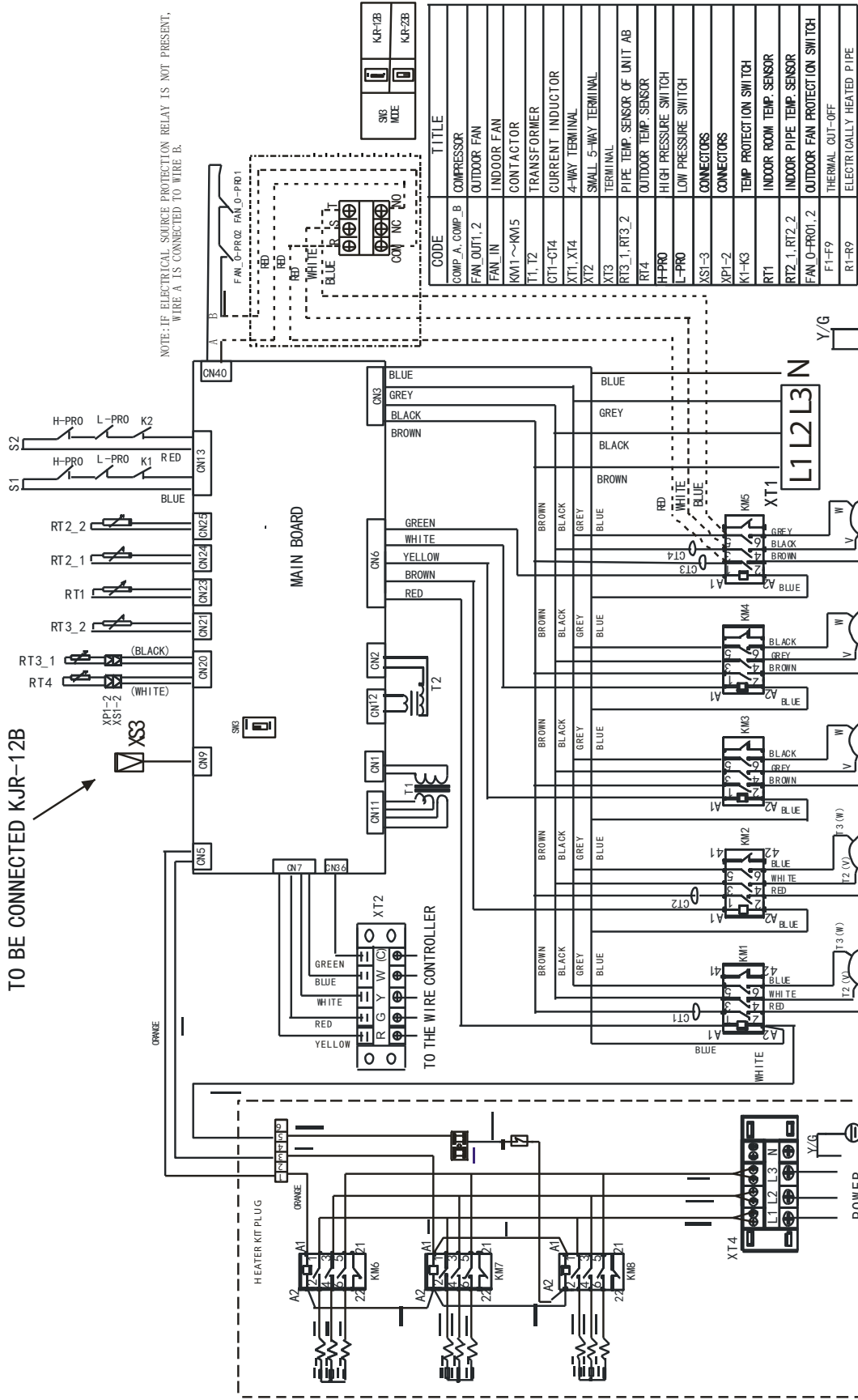

NOTE: IF ELECTRICAL SOURCE PROTECTION RELAY IS NOT PRESENT, WIRE A IS CONNECTED TO WIRE B.

CODE	TITLE
COMP_A_COMP_B	COMPRESSOR
FAN_OUT1_2	OUTDOOR FAN
FAN_IN	INDOOR FAN
KM1~KM5	CONTACTOR
T1, T2	TRANSFORMER
CT1-CT4	CURRENT INDUCTOR
XT1, XT4	4-WAY TERMINAL
XT2	SMALL 5-WAY TERMINAL
XT3	TERMINAL
RT3_1, RT3_2	PIPE TEMP. SENSOR OF UNIT AB
RT4	OUTDOOR TEMP. SENSOR
H-PRO	HIGH PRESSURE SWITCH
L-PRO	LOW PRESSURE SWITCH
XSI-3	CONNECTORS
XPI-2	CONNECTORS
KI-K3	TEMP PROTECTION SWITCH
RT1	INDOOR ROOM TEMP. SENSOR
RT2_1, RT2_2	INDOOR PIPE TEMP. SENSOR
FAN_O-PROT. 2	OUTDOOR FAN PROTECTION SWITCH
F1-F9	THERMAL CUT-OFF
RT-R9	ELECTRICALLY HEATED PIPE

NOTE: TERMINALS XT1 AND XT4 MUST BE SUPPLIED BY THE SAME POWER



7.10 MTZH360DC00300A

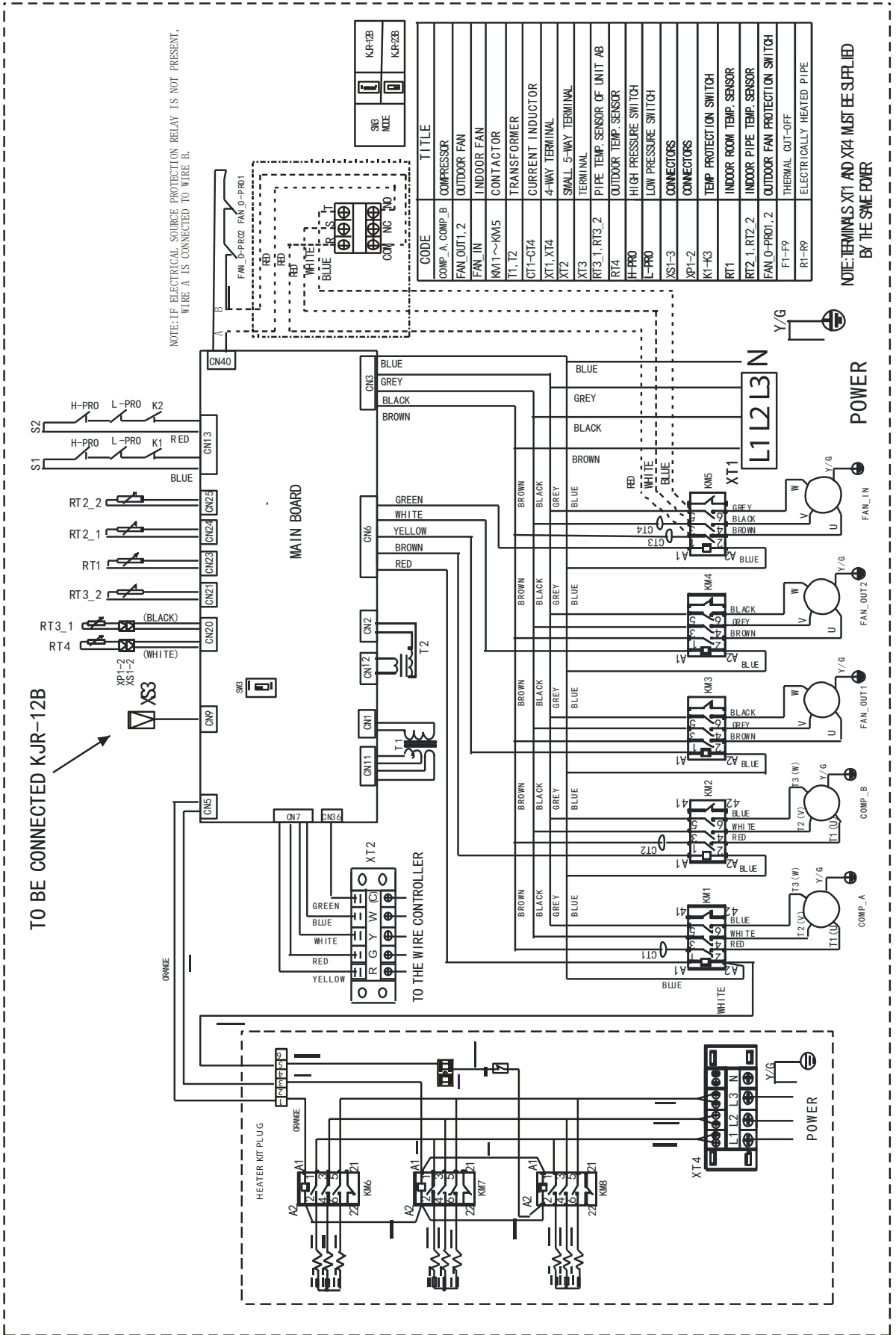

8.6 Cooling capacity for 15Ton:

Ambient Temperature		Air Flow (CFM)		6000				6500				7000			
		Ent (DB)	(°F)	75	80	85	90	75	80	85	90	75	80	85	90
				TC	SC	PI	TC	SC	PI	TC	SC	PI	TC	SC	PI
85	61	TC	159.1	159.6	166.9	176.9	163.5	165.6	173.0	182.9	167.9	171.6	179.1	188.9	
		SC	124.2	146.0	158.5	167.8	131.4	155.8	166.1	175.5	138.6	165.6	173.7	183.2	
		PI	14891.	15171.	15852.	16075.	15041.	15321.	16002.	16225.	15191.	15471.	16152.	16375.	
	67	TC	177.8	181.0	184.2	188.2	183.2	185.5	187.7	190.4	188.6	190.0	191.2	192.6	
		SC	100.0	122.9	142.6	165.8	104.6	127.8	149.9	173.1	109.2	132.7	157.2	180.4	
		PI	15238.	15518.	16148.	16371.	15388.	15668.	16298.	16521.	15538.	15818.	16448.	16671.	
	73	TC	191.3	196.1	197.5	200.1	193.5	197.3	199.9	202.4	195.7	198.5	202.3	204.7	
		SC	70.7	94.6	114.5	134.4	72.1	96.8	117.1	136.6	73.5	99.0	119.7	138.8	
		PI	15738.	16018.	16648.	16871.	15888.	16168.	16798.	17021.	16038.	16318.	16948.	17171.	
	95	61	TC	151.4	152.2	157.4	169.6	153.3	157.1	164.6	175.6	155.2	162.0	171.8	181.6
			SC	117.8	142.5	152.5	164.4	125.2	149.8	159.6	170.3	132.6	157.1	166.7	176.2
			PI	15248.	15498.	16028.	16551.	15398.	15648.	16178.	16701.	15548.	15798.	16328.	16851.
		67	TC	164.3	168.4	170.6	176.7	171.6	174.2	176.7	180.4	178.9	180.0	182.8	184.1
			SC	95.6	117.0	138.8	159.6	99.8	123.0	146.2	169.4	104.0	129.0	153.6	179.2
			PI	15320.	15601.	15893.	16416.	15470.	15751.	16043.	16566.	15620.	15901.	16193.	16716.
		73	TC	187.3	190.0	191.9	193.9	188.7	191.1	193.6	196.3	190.1	192.2	195.3	198.7
			SC	67.4	89.9	111.9	130.5	68.9	93.1	114.9	135.4	70.4	96.3	117.9	140.3
			PI	16120.	16401.	16693.	17216.	16270.	16551.	16843.	17366.	16420.	16701.	16993.	17516.
105	61	TC	137.7	141.5	144.1	161.4	142.6	146.4	153.9	166.3	147.5	151.3	163.7	171.2	
		SC	111.2	135.8	138.3	154.9	119.5	140.5	147.7	159.6	127.8	145.2	157.1	164.3	
		PI	16460.	16690.	16921.	17644.	16610.	16840.	17071.	17794.	16760.	16990.	17221.	17944.	
	67	TC	162.3	163.7	166.1	166.3	163.5	166.1	169.8	171.2	164.7	168.5	173.5	176.1	
		SC	80.1	112.0	132.9	161.0	94.5	118.1	141.4	165.9	108.9	124.2	149.9	170.8	
		PI	16864.	16994.	17487.	18210.	17014.	17144.	17637.	18360.	17164.	17294.	17787.	18510.	
	73	TC	183.1	184.6	185.8	185.9	185.6	187.0	188.3	189.6	188.1	189.4	190.8	193.3	
		SC	64.1	86.1	108.0	126.9	65.5	89.2	111.8	133.0	66.9	92.3	115.6	139.1	
		PI	17364.	17494.	17987.	18710.	17514.	17644.	18137.	18860.	17664.	17794.	18287.	19010.	
115	61	TC	113.9	116.4	128.8	141.2	117.6	122.6	135.0	147.4	121.3	128.8	141.2	153.6	
		SC	94.6	113.9	126.2	138.3	101.7	118.5	130.6	142.6	108.8	123.1	135.0	146.9	
		PI	17061.	17546.	18032.	19010.	17211.	17696.	18182.	19160.	17361.	17846.	18332.	19310.	
	67	TC	139.8	141.0	141.1	145.7	141.0	143.5	144.8	148.4	142.2	146.0	148.5	151.1	
		SC	80.7	94.2	115.3	143.7	85.6	100.7	123.9	147.4	90.5	107.2	132.5	151.1	
		PI	18071.	18201.	18894.	19644.	18221.	18351.	19044.	19794.	18371.	18501.	19194.	19944.	
	73	TC	155.6	158.3	162.2	163.4	160.6	163.2	165.8	167.1	165.6	168.1	169.4	170.8	
		SC	47.9	68.7	92.0	114.2	49.3	72.9	96.3	119.1	50.7	77.1	100.6	124.0	
		PI	18751.	18881.	19574.	20324.	18901.	19031.	19724.	20474.	19051.	19181.	19874.	20624.	
118	61	TC	110.9	113.4	125.8	138.2	114.6	119.6	132.0	144.4	118.3	125.8	138.2	150.6	
		SC	91.6	110.9	123.2	135.3	98.7	115.5	127.6	139.6	105.8	120.1	132.0	143.9	
		PI	16889.	17629.	18370.	19603.	17039.	17779.	18520.	19753.	17189.	17929.	18670.	19903.	
	67	TC	139.3	140.4	140.4	144.9	140.5	142.9	144.1	147.6	141.7	145.4	147.8	150.3	
		SC	80.2	93.6	114.6	142.9	85.1	100.1	123.2	146.6	90.0	106.6	131.8	150.3	
		PI	18271.	18393.	19269.	20049.	18421.	18552.	19419.	20199.	18571.	18711.	19569.	20349.	
	73	TC	152.6	155.3	159.2	160.4	157.6	160.2	162.8	164.1	162.6	165.1	166.4	167.8	
		SC	44.9	65.7	89.0	111.2	46.3	69.9	93.3	116.1	47.7	74.1	97.6	121.0	
		PI	18771.	18902.	19769.	20549.	18921.	19052.	19919.	20699.	19071.	19202.	20069.	20849.	
125	61	TC	109.1	111.5	123.4	132.0	112.6	117.4	129.3	139.6	116.1	123.3	135.2	147.2	
		SC	90.4	107.8	119.4	127.6	97.3	113.5	125.1	135.0	104.2	119.2	130.8	142.4	
		PI	16717.	17712.	18707.	20195.	16867.	17862.	18857.	20345.	17017.	18012.	19007.	20495.	
	67	TC	133.8	135.1	135.3	137.8	135.0	137.5	138.8	141.3	136.2	139.9	142.3	144.8	
		SC	77.1	90.0	110.4	142.5	81.8	96.3	118.7	141.3	86.5	102.6	127.0	140.1	
		PI	18616.	18746.	19714.	20514.	18766.	18896.	19864.	20664.	18916.	19046.	20014.	20814.	
	73	TC	149.3	151.6	155.4	156.7	154.0	156.4	158.9	160.2	158.7	161.2	162.4	163.7	
		SC	45.6	65.6	88.0	109.2	46.9	69.6	92.1	114.0	48.2	73.6	96.2	118.8	
		PI	19116.	19246.	20214.	21014.	19266.	19396.	20364.	21164.	19416.	19546.	20514.	21314.	

Notes: 1. All capacities are gross and have not considered indoor fan heat. To obtain NET cooling capacity subtract indoor fan heat.
 2. TC=Total Capacity. (Unit: 1000Btu/h).
 3. SC=Sensible Capacity. (Unit: 1000Btu/h).



8.7 Cooling capacity for 17.5Ton:

		Air Flow (CFM)		6400				7000				7600			
		Ent (DB)	(°F)	75	80	85	90	75	80	85	90	75	80	85	90
Ambient Temperature	85	61	TC	185.6	188.0	196.5	207.7	190.7	193.1	201.6	212.8	195.8	198.2	206.7	217.9
			SC	148.8	176.8	188.5	199.2	153.9	181.9	193.6	204.3	159.0	187.0	198.7	209.4
			PI	13087.	13343.	15919.	16204.	13977.	14237.	16404.	16689.	14868.	15130.	16889.	17175.
		67	TC	208.2	210.8	213.3	216.3	213.3	215.9	218.4	221.4	218.4	221.0	223.5	226.5
			SC	118.1	144.6	170.0	196.5	123.2	149.7	175.1	201.6	128.3	154.8	180.2	206.7
			PI	15361.	15617.	18193.	18478.	16251.	16511.	18678.	18964.	17142.	17404.	19163.	19449.
		73	TC	220.0	224.3	227.3	230.1	225.1	229.4	232.4	235.2	230.2	234.5	237.5	240.3
			SC	80.8	109.1	132.4	154.6	85.9	114.2	137.5	159.7	91.0	119.3	142.6	164.8
			PI	16528.	16785.	19060.	19445.	17368.	17628.	19545.	19881.	18209.	18472.	20031.	20316.
	95	61	TC	173.9	178.2	186.8	199.3	179.0	183.3	191.9	204.4	184.1	188.4	197.0	209.5
			SC	141.7	169.9	181.1	193.2	146.8	175.0	186.2	198.3	151.9	180.1	191.3	203.4
			PI	14883.	15139.	17415.	17800.	15723.	15983.	17900.	18236.	16564.	16826.	18385.	18671.
		67	TC	194.9	197.8	200.7	204.8	200.0	202.9	205.8	209.9	205.1	208.0	210.9	215.0
			SC	112.6	139.1	165.7	192.2	117.7	144.2	170.8	197.3	122.8	149.3	175.9	202.4
			PI	16657.	16915.	19189.	19574.	17497.	17757.	19674.	20010.	18338.	18600.	20160.	20445.
		73	TC	214.5	217.2	220.1	223.1	219.6	222.3	225.2	228.2	224.7	227.4	230.3	233.3
			SC	77.1	104.9	129.8	153.2	82.2	110.0	134.9	158.3	87.3	115.1	140.0	163.4
			PI	18324.	18581.	20606.	21092.	19115.	19374.	21091.	21477.	19905.	20168.	21577.	21862.
	105	61	TC	161.6	166.0	174.6	188.7	166.7	171.1	179.7	193.8	171.8	176.2	184.8	198.9
			SC	135.1	159.2	167.4	181.0	140.2	164.3	172.5	186.1	145.3	169.4	177.6	191.2
			PI	16679.	16936.	18961.	19446.	17469.	17729.	19446.	19832.	18260.	18523.	19932.	20217.
		67	TC	185.6	188.6	192.8	194.3	190.7	193.7	197.9	199.4	195.8	198.8	203.0	204.5
			SC	106.5	133.5	160.2	188.2	111.6	138.6	165.3	193.3	116.7	143.7	170.4	198.4
			PI	18953.	19210.	21185.	21671.	19744.	20003.	21670.	22056.	20534.	20797.	22156.	22441.
		73	TC	210.9	212.5	214.0	215.4	216.0	217.6	219.1	220.5	221.1	222.7	224.2	225.6
			SC	73.2	100.4	126.3	150.5	78.3	105.5	131.4	155.6	83.4	110.6	136.5	160.7
			PI	21383.	21640.	23438.	24023.	22124.	22384.	23923.	24358.	22864.	23127.	24408.	24694.
	115	61	TC	141.2	146.9	161.1	175.3	146.3	152.0	166.2	180.4	151.4	157.1	171.3	185.5
			SC	123.0	142.2	156.1	169.7	128.1	147.3	161.2	174.8	133.2	152.4	166.3	179.9
			PI	18759.	19016.	20813.	21399.	19500.	19759.	21299.	21734.	20240.	20503.	21784.	22069.
		67	TC	168.1	168.0	172.4	175.3	173.2	176.0	177.5	180.4	178.3	184.0	182.6	185.5
			SC	104.5	121.8	148.4	175.3	109.6	126.9	153.5	180.4	114.7	132.0	158.6	185.5
			PI	20893.	20986.	22897.	23482.	21633.	21893.	23382.	23818.	22374.	22800.	23867.	24153.
		73	TC	190.5	193.5	196.5	197.8	195.6	198.6	201.6	202.9	200.7	203.7	206.7	208.0
			SC	62.9	90.0	116.8	142.8	68.0	95.1	121.9	147.9	73.1	100.2	127.0	153.0
			PI	23197.	23454.	25101.	25787.	23888.	24147.	25587.	26072.	24578.	24841.	26072.	26357.
118	61	TC	135.4	141.1	155.3	169.5	140.5	146.2	160.4	174.6	145.6	151.3	165.5	179.7	
		SC	117.2	136.4	150.3	163.9	122.3	141.5	155.4	169.0	127.4	146.6	160.5	174.1	
		PI	19461.	19718.	21365.	22051.	20152.	20411.	21851.	22336.	20842.	21105.	22336.	22621.	
	67	TC	170.0	173.6	174.3	177.2	175.1	177.9	179.4	182.3	180.2	182.2	184.5	187.4	
		SC	101.4	118.7	145.3	172.2	106.5	123.8	150.4	177.3	111.6	128.9	155.5	182.4	
		PI	21157.	21215.	23061.	23747.	21847.	22107.	23546.	24032.	22538.	23000.	24032.	24317.	
	73	TC	184.7	187.7	190.7	192.0	189.8	192.8	195.8	197.1	194.9	197.9	200.9	202.2	
		SC	57.1	84.2	111.0	137.0	62.2	89.3	116.1	142.1	67.3	94.4	121.2	147.2	
		PI	23774.	24156.	25653.	26439.	24415.	24799.	26139.	26674.	25055.	25443.	26624.	26909.	
125	61	TC	135.5	141.0	154.6	166.3	140.6	146.1	159.7	171.4	145.7	151.2	164.8	176.5	
		SC	117.9	136.5	149.8	161.0	123.0	141.6	154.9	166.1	128.1	146.7	160.0	171.2	
		PI	20895.	21276.	22774.	23559.	21536.	21920.	23259.	23795.	22176.	22563.	23744.	24030.	
	67	TC	161.2	164.0	165.5	168.3	166.3	169.1	170.6	173.4	171.4	174.2	175.7	178.5	
		SC	92.1	116.8	142.5	168.3	97.2	121.9	147.6	173.4	102.3	127.0	152.7	178.5	
		PI	21553.	21934.	23482.	24267.	22193.	22578.	23967.	24502.	22834.	23221.	24452.	24738.	
	73	TC	183.0	185.7	188.6	189.9	188.1	190.8	193.7	195.0	193.2	195.9	198.8	200.1	
		SC	60.2	86.2	112.0	137.0	65.3	91.3	117.1	142.1	70.4	96.4	122.2	147.2	
		PI	23975.	24357.	25754.	26540.	24616.	25000.	26239.	26775.	25256.	25644.	26725.	27010.	

- Notes: 1. All capacities are gross and have not considered indoor fan heat. To obtain NET cooling capacity subtract indoor fan heat.
2. TC=Total Capacity. (Unit: 1000Btu/h).
3. SC=Sensible Capacity. (Unit: 1000Btu/h).



8.8 Cooling capacity for 20Ton:

Air Flow (CFM)			6800				7800				8800				
Ambient Temperature	Ent	(°F)	75	80	85	90	75	80	85	90	75	80	85	90	
		85	61	TC	210.3	210.8	220.7	233.4	216.2	218.8	228.6	241.4	222.1	226.8	236.5
SC	164.2			193.2	214.0	226.5	173.8	206.0	221.7	234.2	183.4	218.8	229.4	241.9	
PI	19958.3			20056.5	20886.8	20830.5	20278.5	20347.6	20902.9	20918.6	20598.6	20638.7	20919.0	21006.7	
67	TC		235.0	239.2	243.2	248.3	242.2	245.2	247.9	251.3	249.4	251.2	252.6	254.3	
	SC		132.2	162.4	188.4	219.0	138.4	168.9	198.0	228.6	144.6	175.4	207.6	238.2	
	PI		20905.1	21063.9	21358.2	21680.3	21474.3	21613.6	21796.9	22002.3	22043.4	22163.4	22235.5	22324.4	
73	TC		253.0	259.2	260.7	264.3	255.9	260.8	264.0	267.3	258.8	262.4	267.3	270.3	
	SC		93.7	125.1	151.1	177.4	95.5	128.0	154.6	180.3	97.3	130.9	158.1	183.2	
	PI		22679.2	22774.2	22901.9	22957.4	22772.2	22857.5	23029.6	23085.1	22865.2	22940.7	23157.3	23212.8	
95	61		TC	200.1	201.1	207.8	223.8	202.7	207.6	217.4	231.8	205.3	214.1	227.0	239.8
			SC	156.0	190.4	203.7	219.6	165.7	198.0	210.8	224.9	175.4	205.6	217.9	230.2
			PI	19336.4	19495.2	20325.4	20269.2	19646.9	19786.3	20341.6	20357.3	19957.4	20077.4	20357.7	20445.4
	67		TC	217.5	220.4	225.6	233.4	227.0	230.2	233.5	238.2	236.5	240.0	241.4	243.0
			SC	126.6	154.6	183.5	210.9	132.1	162.6	193.2	223.7	137.6	170.6	202.9	236.5
			PI	20283.3	20502.6	20796.9	21118.9	20842.7	21052.3	21235.5	21441.0	21402.1	21602.0	21674.2	21763.1
	73		TC	247.7	251.1	253.4	255.8	249.5	252.6	255.7	259.1	251.3	254.1	258.0	262.4
			SC	89.4	118.9	147.6	172.2	91.3	123.1	151.7	178.7	93.2	127.3	155.8	185.2
			PI	22057.3	22212.8	22340.5	22396.1	22140.6	22296.1	22468.2	22523.8	22223.9	22379.4	22596.0	22651.5
	105	61	TC	182.1	187.0	190.2	213.0	188.6	193.5	203.2	219.5	195.1	200.0	216.2	226.0
			SC	147.1	181.4	184.5	206.6	158.1	187.7	197.1	212.9	169.1	194.0	209.7	219.2
			PI	22036.1	22194.9	23025.1	22968.9	22346.6	22486.0	23041.2	23057.0	22657.1	22777.1	23057.4	23145.1
		67	TC	214.5	216.3	219.6	219.5	216.2	219.5	224.4	226.0	217.9	222.7	229.2	232.5
			SC	106.1	148.0	175.6	228.8	125.1	156.1	186.8	219.0	144.1	164.2	198.0	209.2
			PI	22231.1	22450.5	22744.8	23066.8	22790.6	23000.2	23183.4	23388.9	23350.0	23549.9	23622.1	23710.9
		73	TC	242.3	243.8	245.4	245.6	245.5	247.1	248.7	250.4	248.7	250.4	252.0	255.2
			SC	84.7	113.7	142.7	167.6	86.7	117.9	147.7	175.6	88.7	122.1	152.7	183.6
			PI	24905.2	25060.7	25188.4	25243.9	24988.5	25144.0	25316.1	25371.6	25071.8	25227.2	25443.8	25499.3
115		61	TC	174.1	177.3	193.5	209.8	178.9	185.4	201.6	217.9	183.7	193.5	209.7	226.0
			SC	148.5	172.1	188.0	203.6	157.9	180.0	195.8	211.5	167.3	187.9	203.6	219.4
			PI	23618.2	23777.0	24607.2	24551.0	23928.7	24068.1	24623.4	24639.1	24239.2	24359.2	24639.5	24727.2
		67	TC	191.0	192.8	192.7	196.1	192.7	196.0	197.6	200.9	194.4	199.2	202.5	205.7
			SC	113.1	130.8	158.6	196.1	119.6	139.4	170.0	200.9	126.1	148.0	181.4	205.7
			PI	23813.3	24064.6	24326.9	24648.9	24372.7	24582.3	24765.5	24971.0	24932.1	25100.0	25204.2	25293.1
		73	TC	212.2	215.5	220.3	222.1	218.7	222.0	225.2	226.9	225.2	228.5	230.1	231.7
			SC	69.9	97.2	127.7	157.0	71.7	102.7	133.4	163.5	73.5	108.2	139.1	170.0
			PI	26910.5	27066.0	27193.7	27249.2	26993.8	27149.3	27321.4	27376.9	27077.1	27232.6	27449.1	27504.6
	118	61	TC	170.5	173.7	189.9	206.2	175.3	181.8	198.0	214.3	180.1	189.9	206.1	222.4
			SC	144.9	168.5	184.4	200.0	154.3	176.4	192.2	207.9	163.7	184.3	200.0	215.8
			PI	23989.2	24148.0	24978.2	24922.0	24299.7	24439.1	24994.4	25010.1	24610.2	24730.2	25010.5	25098.2
		67	TC	190.1	191.7	191.4	194.6	191.8	194.9	196.3	199.4	193.5	198.0	201.2	204.2
			SC	112.2	129.7	157.3	194.6	118.7	138.3	168.7	199.4	125.2	146.9	180.1	204.2
			PI	24184.3	24510.6	24697.9	25019.9	24743.7	24953.3	25136.5	25342.0	25303.1	25396.0	25575.2	25664.1
		73	TC	208.6	211.9	216.7	218.5	215.1	218.4	221.6	223.3	221.6	224.9	226.5	228.1
			SC	66.3	93.6	124.1	153.4	68.1	99.1	129.8	159.9	69.9	104.6	135.5	166.4
			PI	27276.9	27432.3	27560.1	27615.6	27360.2	27515.6	27687.8	27743.3	27443.4	27598.9	27815.5	27871.0
125		61	TC	147.5	150.5	166.0	181.2	152.1	158.2	173.6	188.9	156.7	165.9	181.2	196.6
			SC	123.4	145.8	160.5	175.5	132.3	153.2	168.0	182.9	141.2	160.6	175.5	190.3
			PI	24539.2	24698.0	25528.2	25472.0	24849.7	24989.1	25544.4	25560.1	25160.2	25280.2	25560.5	25648.2
		67	TC	179.6	181.2	181.2	206.3	181.2	184.3	185.8	199.9	182.8	187.4	190.4	193.5
			SC	106.0	122.7	149.1	168.4	112.2	130.9	159.8	178.9	118.4	139.1	170.5	189.4
			PI	24734.3	24953.6	25247.9	25569.9	25293.7	25503.3	25686.5	25892.0	25853.1	26053.0	26125.2	26214.1
		73	TC	199.7	202.6	207.3	208.8	205.8	208.8	211.9	213.4	211.9	215.0	216.5	218.0
			SC	65.3	91.1	120.0	147.4	67.0	96.3	125.3	153.6	68.7	101.5	130.6	159.8
			PI	27676.9	27832.3	27960.1	28015.6	27760.2	27915.6	28087.8	28143.3	27843.4	27998.9	28215.5	28271.0

- Notes:
1. All capacities are gross and have not considered indoor fan heat. To obtain NET cooling capacity subtract indoor fan heat.
 2. TC=Total Capacity. (Unit: 1000Btu/h).
 3. SC=Sensible Capacity. (Unit: 1000Btu/h).

8.9 Cooling capacity for 25Ton:

Air Flow (CFM)			8000				9000				10000				
Ent (DB)	(°F)		75	80	85	90	75	80	85	90	75	80	85	90	
Ambient Temperature	85	61	TC	266.7	272.2	277.9	283.6	273.9	279.6	285.4	291.3	280.7	286.5	292.4	298.5
			SC	231.4	236.2	241.2	246.2	247.4	252.6	257.8	263.2	262.4	267.9	273.4	279.1
			PI	24732.7	24932.6	25004.8	25132.5	25022.7	25222.6	25294.8	25422.5	25312.7	25512.6	25584.8	25712.5
		67	TC	297.9	304.1	310.4	316.8	300.9	307.1	313.5	320.0	303.7	309.9	316.3	322.9
			SC	172.4	219.4	265.2	301.4	178.4	230.2	284.4	310.7	186.9	262.7	280.7	315.4
			PI	25232.7	25432.6	25504.8	25632.5	25522.7	25722.6	25794.8	25922.5	25812.7	26012.6	26084.8	26212.5
		73	TC	309.2	315.5	322.1	328.7	310.2	316.6	323.1	329.8	310.9	317.3	323.9	330.6
			SC	108.7	161.7	198.2	237.7	110.2	163.9	205.2	256.2	111.9	169.7	220.4	260.4
			PI	25809.0	26013.3	26086.8	26217.1	26119.0	26323.3	26396.8	26527.1	26429.0	26633.3	26706.8	26837.1
	95	61	TC	246.4	251.5	256.8	262.1	254.2	259.4	264.8	270.4	261.7	267.1	272.6	278.3
			SC	221.2	225.8	230.5	235.3	237.4	242.4	247.4	252.6	252.9	258.6	263.5	269.0
			PI	24500.5	24682.6	24749.6	24866.6	24750.5	24932.6	24999.6	25116.6	25000.5	25182.6	25249.6	25366.6
		67	TC	273.7	279.3	285.1	291.0	278.2	289.4	295.4	301.5	293.9	300.0	306.2	312.5
			SC	166.4	213.9	258.4	297.9	175.2	226.4	274.4	300.2	182.9	257.6	270.4	310.4
			PI	26710.1	26910.0	26982.2	27109.9	27000.1	27200.0	27272.2	27399.9	27300.1	27500.0	27572.2	27699.9
		73	TC	306.4	312.7	319.2	325.8	307.2	313.5	320.0	326.6	308.9	315.3	321.8	328.5
			SC	105.2	152.9	193.2	233.9	107.4	156.2	200.2	251.7	108.2	158.4	208.9	251.2
			PI	28599.0	28808.0	28882.9	29016.2	28909.0	29118.0	29192.9	29326.2	29219.0	29428.0	29502.9	29636.2
	105	61	TC	225.7	230.4	235.2	240.1	233.9	238.8	243.8	248.9	238.9	243.9	249.0	254.2
			SC	210.9	215.3	219.8	224.5	227.4	232.2	237.0	242.0	222.9	227.6	232.3	237.2
			PI	26487.9	26670.0	26737.0	26854.0	26737.9	26920.0	26987.0	27104.0	26987.9	27170.0	27237.0	27354.0
		67	TC	265.2	270.7	276.3	282.0	271.7	277.3	283.1	288.9	275.9	281.6	287.5	293.4
			SC	158.4	205.4	254.2	278.4	167.7	219.7	269.4	284.2	174.9	235.2	265.2	280.9
			PI	29197.5	29397.4	29469.6	29597.3	29487.5	29687.4	29759.6	29887.3	29787.5	29987.4	30059.6	30187.3
		73	TC	298.9	305.1	311.4	317.8	300.9	307.1	313.5	320.0	302.4	308.7	315.0	321.6
			SC	100.2	147.4	186.9	223.2	102.4	153.4	192.7	248.7	103.7	153.2	199.2	246.4
			PI	32028.6	32245.5	32322.5	32460.3	32338.6	32555.5	32632.5	32770.3	32648.6	32865.5	32942.5	33080.3
	115	61	TC	198.2	202.5	206.9	211.4	205.4	209.9	214.4	219.0	213.2	217.8	222.5	227.3
			SC	193.9	198.1	202.4	206.8	197.9	202.2	206.6	211.1	207.9	212.4	217.0	221.7
			PI	28475.3	28657.4	28724.4	28841.4	28725.3	28907.4	28974.4	29091.4	28975.3	29157.4	29224.4	29341.4
		67	TC	235.7	240.7	245.9	251.2	240.4	245.6	250.8	256.2	246.4	251.7	257.1	262.6
			SC	141.2	190.4	237.7	242.8	150.7	202.9	245.7	250.9	159.4	217.7	250.7	258.7
			PI	31184.9	31384.8	31457.0	31584.7	31474.9	31674.8	31747.0	31874.7	31774.9	32400.8	32501.0	32574.7
		73	TC	280.4	286.4	292.4	298.6	282.7	288.7	294.8	301.0	284.4	290.4	296.6	302.9
			SC	87.9	135.7	174.9	204.2	89.7	142.7	177.9	235.2	91.7	141.9	185.2	230.7
			PI	36055.2	36279.1	36355.6	36496.3	36365.2	36589.1	36665.6	36806.3	36675.2	36899.1	36975.6	37116.3
118	61	TC	195.5	199.8	204.2	208.7	202.7	207.2	211.7	216.3	210.5	215.1	219.8	224.6	
		SC	191.2	195.4	199.7	204.1	195.2	199.5	203.9	208.4	205.2	209.7	214.3	219.0	
		PI	29071.5	29253.6	29320.6	29437.6	29321.5	29503.6	29570.6	29687.6	29571.5	29753.6	29820.6	29937.6	
	67	TC	233.0	238.0	243.2	248.5	237.7	242.9	248.1	253.5	243.7	249.0	254.4	259.9	
		SC	138.5	187.7	235.0	240.1	148.0	200.2	243.0	248.2	156.7	215.0	248.0	256.0	
		PI	31781.1	31981.0	32053.2	32180.9	32071.1	32271.0	32343.2	32470.9	32371.1	32571.0	32643.2	32770.9	
	73	TC	277.7	283.7	289.7	295.9	280.0	286.0	292.1	298.3	281.7	287.7	293.9	300.2	
		SC	85.2	133.0	172.2	201.5	87.0	140.0	175.2	232.5	89.0	139.2	182.5	228.0	
		PI	36798.7	37018.0	37096.8	37236.4	37108.7	37328.0	37406.8	37546.4	37418.7	37638.0	37716.8	37856.4	
125	61	TC	175.5	179.5	183.5	187.5	182.1	186.2	190.3	194.5	189.2	193.4	197.6	202.0	
		SC	171.7	175.5	179.4	183.4	175.3	179.2	183.2	187.3	184.4	188.5	192.7	196.9	
		PI	30462.7	30644.8	30711.8	30828.8	30712.7	30894.8	30961.8	31078.8	30962.7	31144.8	31211.8	31328.8	
	67	TC	209.6	214.2	218.9	223.7	213.9	218.6	223.4	228.3	219.4	224.2	229.1	234.1	
		SC	123.7	168.5	211.4	216.1	132.4	179.9	218.7	223.5	140.3	193.3	223.3	230.5	
		PI	33172.3	33372.2	33444.4	33572.1	33462.3	33662.2	33734.4	33862.1	33762.3	33962.2	34034.4	34162.1	
	73	TC	250.3	255.7	261.3	266.9	252.4	257.8	263.4	269.1	253.9	259.4	265.0	270.7	
		SC	75.3	118.7	154.4	181.0	76.9	125.1	157.1	209.2	78.7	124.4	163.7	205.1	
		PI	38458.3	38679.8	38753.7	38892.1	38768.3	38989.8	39063.7	39202.1	39078.3	39299.8	39373.7	39512.1	

- Notes: 1. All capacities are gross and have not considered indoor fan heat. To obtain NET cooling capacity subtract indoor fan heat.
2. TC=Total Capacity. (Unit: 1000Btu/h).
3. SC=Sensible Capacity. (Unit: 1000Btu/h).



8.10 Cooling capacity for 30Ton:

		Air Flow (CFM)		9000				105000				12000			
		Ent (DB)	(°F)	75	80	85	90	75	80	85	90	75	80	85	90
Ambient Temperature	85	61	TC	311.2	312.0	325.9	345.1	319.7	323.6	337.7	356.7	328.2	335.2	349.5	368.3
			SC	248.1	289.9	314.0	337.7	262.0	308.9	328.7	346.6	275.9	327.9	343.4	355.5
			PI	27143.	27752.	28995.	30630.	27343.	27952.	29195.	30830.	27543.	28152.	29395.	31030.
		67	TC	347.3	353.4	359.3	367.0	357.8	362.1	366.1	371.2	368.3	370.8	372.9	375.4
			SC	201.2	245.3	283.1	327.9	210.1	254.8	297.3	342.0	219.0	264.3	311.5	356.1
			PI	30430.	30648.	30830.	31048.	30730.	30948.	31130.	31348.	31030.	31248.	31430.	31648.
		73	TC	373.4	382.6	385.0	390.0	377.7	384.9	389.7	394.4	382.0	387.2	394.4	398.8
			SC	144.6	190.7	228.8	267.1	147.3	194.9	233.9	271.4	150.0	199.1	239.0	275.7
			PI	31422.	31874.	32500.	32883.	31822.	32274.	32900.	33283.	32222.	32674.	33300.	33683.
	95	61	TC	296.3	270.5	307.6	330.9	300.0	307.2	321.5	342.5	303.7	343.9	335.4	354.1
			SC	235.7	287.9	302.4	325.2	250.0	297.3	316.1	336.6	264.3	306.7	329.8	348.0
			PI	27535.	31366.	30556.	32337.	27735.	31566.	30756.	32537.	27935.	31766.	30956.	32737.
		67	TC	338.6	341.0	343.4	354.9	345.7	350.5	355.2	362.1	352.8	360.0	367.0	369.3
			SC	140.8	181.9	247.9	325.8	200.9	245.5	290.2	334.8	261.0	309.1	332.5	343.8
			PI	32014.	32700.	33366.	33586.	32314.	33000.	33666.	33886.	32614.	33300.	33966.	34186.
		73	TC	365.8	370.8	374.2	378.0	368.5	372.9	377.5	382.6	371.2	375.0	380.8	387.2
			SC	138.2	181.5	223.9	259.6	141.1	187.7	229.7	269.1	144.0	193.9	235.5	278.6
			PI	33567.	33929.	34481.	35091.	33967.	34329.	34881.	35491.	34367.	34729.	35281.	35891.
	105	61	TC	269.8	277.0	281.9	315.2	279.3	286.5	300.8	324.6	288.8	296.0	319.7	334.0
			SC	223.0	270.4	274.9	306.8	239.0	279.4	293.1	315.9	255.0	288.4	311.3	325.0
			PI	34180.	35067.	37987.	39749.	34380.	35267.	38187.	39949.	34580.	35467.	38387.	40149.
		67	TC	317.3	320.0	324.3	324.5	319.7	324.6	331.5	334.0	322.1	329.2	338.7	343.5
			SC	162.7	224.4	264.5	318.6	190.6	236.1	280.9	328.1	218.5	247.8	297.3	337.6
			PI	38083.	38957.	40128.	40719.	38383.	39257.	40428.	41019.	38683.	39557.	40728.	41319.
73		TC	357.7	360.4	362.5	362.4	362.5	365.0	367.3	369.6	367.3	369.6	372.1	376.8	
		SC	131.9	174.2	216.4	252.7	134.6	180.2	223.7	264.5	137.3	186.2	231.0	276.3	
		PI	43451.	43735.	44043.	44622.	43851.	44135.	44443.	45022.	44251.	44535.	44843.	45422.	
115	61	TC	264.3	269.0	292.8	316.6	271.5	281.0	304.8	328.6	278.7	293.0	316.8	340.6	
		SC	221.4	258.5	282.1	305.3	235.1	267.4	290.6	313.6	248.8	276.3	299.1	321.9	
		PI	34244.	36021.	38980.	41938.	34444.	36221.	39180.	42138.	34644.	36421.	39380.	42338.	
	67	TC	324.5	326.5	328.5	331.5	326.8	331.4	333.7	338.6	329.1	336.3	338.9	345.7	
		SC	220.2	246.1	286.5	331.7	229.6	258.6	303.2	327.7	239.0	271.1	319.9	323.7	
		PI	39509.	40404.	40727.	41572.	40609.	41504.	41827.	42672.	41709.	42604.	42927.	43772.	
	73	TC	335.1	340.0	347.3	349.6	344.7	349.5	354.3	356.7	354.3	359.0	361.3	363.8	
		SC	128.1	171.1	216.0	258.8	133.8	179.2	224.3	268.2	139.5	187.3	232.6	277.6	
		PI	43241.	43826.	44112.	44422.	43641.	44226.	44512.	44822.	44041.	44626.	44912.	45222.	
118	61	TC	262.3	267.0	290.8	314.6	269.5	279.0	302.8	326.6	276.7	291.0	314.8	338.6	
		SC	219.4	256.5	280.1	303.3	233.1	265.4	288.6	311.6	246.8	274.3	297.1	319.9	
		PI	35135.	36972.	40028.	43085.	35335.	37172.	40228.	43285.	35535.	37372.	40428.	43485.	
	67	TC	322.5	324.5	326.5	329.5	324.8	329.4	331.7	336.6	327.1	334.3	336.9	343.7	
		SC	218.2	244.1	284.5	329.7	227.6	256.6	301.2	325.7	237.0	269.1	317.9	321.7	
		PI	41408.	42330.	42666.	43540.	41708.	42630.	42966.	43840.	42008.	42930.	43266.	44140.	
	73	TC	333.1	338.0	345.3	347.6	342.7	347.5	352.3	354.7	352.3	357.0	359.3	361.8	
		SC	126.1	169.1	214.0	256.8	131.8	177.2	222.3	266.2	137.5	185.3	230.6	275.6	
		PI	44444.	45048.	45343.	45664.	44844.	45448.	45743.	46064.	45244.	45848.	46143.	46464.	
125	61	TC	239.2	243.6	266.4	282.8	245.9	255.0	277.8	297.5	252.6	266.4	289.2	312.2	
		SC	207.3	200.7	222.8	238.6	220.6	231.7	253.9	272.9	233.9	262.7	285.0	307.2	
		PI	38151.	40257.	43737.	47247.	38351.	40457.	43937.	47447.	38551.	40657.	44137.	47647.	
	67	TC	286.9	289.1	289.3	294.0	289.2	293.8	296.1	300.8	291.5	298.5	302.9	307.6	
		SC	155.1	206.4	245.6	277.4	177.1	218.5	261.6	285.1	199.1	230.6	277.6	292.8	
		PI	43888.	44956.	45628.	46345.	44188.	45256.	45928.	46645.	44488.	45556.	46228.	46945.	
	73	TC	316.8	321.2	328.2	330.5	325.9	330.4	335.0	337.3	335.0	339.6	341.8	344.1	
		SC	120.5	159.0	202.1	243.0	123.1	166.8	210.1	252.3	125.7	174.6	218.1	261.6	
		PI	50327.	51029.	51364.	51715.	50727.	51429.	51764.	52115.	51127.	51829.	52164.	52515.	

- Notes: 1. All capacities are gross and have not considered indoor fan heat. To obtain NET cooling capacity subtract indoor fan heat.
 2. TC=Total Capacity. (Unit: 1000Btu/h).
 3. SC=Sensible Capacity. (Unit: 1000Btu/h).



9. Electrical Data

Tropical Application

Model	Power Supply			Compressor				Evaporator fan motor			Condenser fan motor		
	MCA	TOCA	MFA	STC	RNC	IPT	Qty	RNC	IPT	Qty	RNC (each)	IPT (each)	Qty
6.2	23.5	28.9	33.2	75	9.7	5.65	1	7.22	1.62	1	3.65	0.83	1
7.5	29.4	36.5	43.7	121.2	14.3	8.08	1	7.18	1.61	1	3.93	0.88	1
8.5	29.6	36.3	47.2	62	8.8	5.13	2	2.90	1.39	1	3.93	0.88	1
10	30.2	37.3	49.4	66	9.6	5.7	2	3.50	1.84	1	2.51	0.98	1
12.5	41.5	52.9	66.4	64+139	8.3+16.6	4.75+9.16	1+1	4.84	2.03	1	3.66	0.83	1
15	45.4	58.1	72.4	64+144	8.3+18.7	4.75+10.8	1+1	7.50	3.97	1	2.80	1.27	1
17.5	57.4	68.1	90.6	139	16.6	9.16	2	6.60	3.03	1	3.53	0.80	2
20	64.1	77.9	101.5	144	18.7	10.8	2	8.90	4.35	1	2.84	1.29	2
25	74.7	93.4	116.0	158	20.66	12.1	2	9.70	4.4	1	3.71	2.07	2
30	84.3	104.6	133.4	197	24.52	13.7	2	13.6	7.4	1	3.71	2.07	2

Voltage imbalance between phases to be <2%

MCA: Min. Current Amps. (A)

TOCA: Total Over-current Amps. (A)

MFA: Max. Fuse Amps. (A)

STC: Starting Current (A)

RNC: Running Current (A)

IPT: Input (kW)

10. Fan performance data

10.1 Blower drive options

Power supply	Nominal capacity(ton)	MOTOR			BLOWER		
		HP	RPM	PULLEY PITCH DIA. (INCH)	SPEED RANGE (RPM)		PULLEY PITCH DIA. (INCH)
					MINIMUM	MAXIMUM	
380-415V 3ph~ 50Hz	8.5	2	1400	4.53~5.25	821	918	8.35
	10	2	1400	4.53~5.25	931	1016	7.48
	12.5	4	1420	4.53~5.25	769	871	8.82
	15	5.3	1440	4.53~5.25	949	1112	7.48
	17.5	5.3	1440	4.53~5.25	927	1045	9.84
	20	5.3	1440	4.53~5.25	1081	1284	5.91
	25	7.3	1440	4.53~5.25	925	1088	7.09
	30	7.3	1440	4.53~5.25	1022	1195	6.30

Example for selection process:

The following data are the rated design points for model 8.5 ton:

Air flow(CFM)=3520CFM, External static pressure(ESP)=75Pa

Fan speed(RPM)=862, Power input(W)=1405, The no. of turns (N) =1

To increase the ESP to 100Pa, but maintain the airflow rate at 3500CFM,

Please follow the steps below:

Step 1: Selection of new desired point.

From the table data, select the point that can meet both of the requirements (ESP = 100Pa and airflow rate(near or equal to) = 3500CFM).

Step 2: Read Fan speed(RPM), Power input(W):

Air flow(CFM)=3483CFM, Fan speed(RPM)=896, Power input(W)=1400

Step 3: Read number of turns for variable pitch pulley.

Similarly, use this RPM value to read the no. of turns (N) by referring to the table of 'Motor Variable Pitch Pulley Data'. The variable pitch pulley for motor shall be adjusted to this 'N' in order to achieve the desired point (ESP = 100Pa and airflow rate =3483cfm).

For instance, from the table, no. of turns (N) =0.25 in order to get 3483CFM. First, adjust the motor pulley to 0 turns. Then, makes 0.25 turns on the pulley. Cross check the dimension 'X', which stands for regulation space of motor pulley. In this case, X =1mm.



10.2 Model: 6.2Ton

Static pressure(Pa)		High speed	Middle speed	Low speed
0	Fan speed(RPM)	1001	901	810
	Power input(W)	1665	1386	1164
	Air flow(CFM)	3001	2647	2356
50	Fan speed(RPM)	1063	972	899
	Power input(W)	1607	1341	1133
	Air flow(CFM)	2909	2564	2270
80	Fan speed(RPM)	1098	1016	946
	Power input(W)	1582	1317	1120
	Air flow(CFM)	2825	2503	2190
100	Fan speed(RPM)	1122	1047	977
	Power input(W)	1526	1280	1079
	Air flow(CFM)	2759	2401	2105
150	Fan speed(RPM)	1173	1106	/
	Power input(W)	1452	1230	/
	Air flow(CFM)	2560	2250	/
200	Fan speed(RPM)	1219	1162	/
	Power input(W)	1375	1182	/
	Air flow(CFM)	2367	2109	/
250	Fan speed(RPM)	1265	/	/
	Power input(W)	1305	/	/
	Air flow(CFM)	2182	/	/

10.3 Model: 7.5Ton

Static pressure(Pa)		High speed	Middle speed	Low speed
0	Fan speed(RPM)	1035	936	844
	Power input(W)	1716	1432	1197
	Air flow(CFM)	3074	2697	2403
50	Fan speed(RPM)	1081	991	909
	Power input(W)	1652	1409	1160
	Air flow(CFM)	2981	2596	2284
80	Fan speed(RPM)	1110	1026	954
	Power input(W)	1650	1360	1137
	Air flow(CFM)	2951	2574	2223
100	Fan speed(RPM)	1127	1051	984
	Power input(W)	1591	1377	1126
	Air flow(CFM)	2825	2438	2146
150	Fan speed(RPM)	1173	1110	/
	Power input(W)	1525	1338	/
	Air flow(CFM)	2657	2313	/
200	Fan speed(RPM)	1217	1165	/
	Power input(W)	1449	1281	/
	Air flow(CFM)	2483	2187	/
250	Fan speed(RPM)	1263	/	/
	Power input(W)	1420	/	/
	Air flow(CFM)	2331	/	/



10.4 Model: 8.5Ton

ESP(Pa)	N	0	0.25	0.5	0.75	1	1.25	1.5	1.75	2
	X	0.5	1	1.5	2	2.5	3	3.5	4	4.5
0	Fan speed(RPM)	896	887	876	866	855	847	839	830	821
	Power input(W)	1790	1720	1710	1665	1620	1560	1500	1445	1390
	Air flow(CFM)	4320	4213	4166	4130	4094	4041	3988	3946	3905
25	Fan speed(RPM)	899	890	878	867	857	849	842	849	823
	Power input(W)	1710	1640	1630	1590	1550	1490	1430	1378	1325
	Air flow(CFM)	4134	4035	3987	3943	3899	3855	3810	3761	3713
50	Fan speed(RPM)	902	893	880	869	858	851	844	851	825
	Power input(W)	1630	1560	1550	1515	1480	1420	1360	1310	1260
	Air flow(CFM)	3947	3858	3808	3756	3705	3669	3632	3577	3521
75	Fan speed(RPM)	904	896	880	871	862	854	847	854	827
	Power input(W)	1555	1485	1467	1436	1405	1345	1285	1235	1185
	Air flow(CFM)	3770	3675	3620	3570	3520	3470	3420	3364	3307
100	Fan speed(RPM)	907	896	885	876	866	858	849	858	828
	Power input(W)	1470	1400	1390	1360	1330	1265	1200	1150	1100
	Air flow(CFM)	3582	3483	3428	3321	3215	3215	3215	3154	3092
125	Fan speed(RPM)	910	900	886	877	869	860	852	860	830
	Power input(W)	1375	1310	1295	1265	1235	1175	1115	1065	1015
	Air flow(CFM)	3362	3266	3206	3122	3039	3005	2971	2901	2831
150	Fan speed(RPM)	913	903	887	879	871	863	854	863	832
	Power input(W)	1280	1220	1200	1170	1140	1085	1030	980	930
	Air flow(CFM)	3141	3048	2984	2924	2864	2795	2727	2649	2570
175	Fan speed(RPM)	915	906	892	883	874	865	857	/	/
	Power input(W)	1170	1115	1095	1068	1040	945	850	/	/
	Air flow(CFM)	2851	2761	2683	2619	2555	2325	2094	/	/
200	Fan speed(RPM)	918	909	897	887	876	868	859	/	/
	Power input(W)	1060	1010	990	965	940	805	670	/	/
	Air flow(CFM)	2560	2473	2383	2315	2246	1854	1462	/	/

Notes:

1. Legend: X: Regulation Space of Motor Pulley (mm); N: Number of Turns; ESP: External Static Pressure (Pa);
2. PULLEY PITCH Factory set point: The table, no. of turns (N) =1.5;
3. Bold data is the performance testing set point;
4. Shading data are rated airflow.

10.5 Model: 10Ton

ESP(Pa)	N	0	0.25	0.5	0.75	1	1.25	1.5	1.75	2
	X	0.5	1	1.5	2	2.5	3	3.5	4	4.5
0	Fan speed(RPM)	/	/	/	/	/	/	962	946	931
	Power input(W)	/	/	/	/	/	/	2020	1945	1870
	Air flow(CFM)	/	/	/	/	/	/	4571	4500	4428
25	Fan speed(RPM)	/	/	/	/	/	969	964	969	933
	Power input(W)	/	/	/	/	/	2010	1930	1855	1780
	Air flow(CFM)	/	/	/	/	/	4442	4398	4323	4248
50	Fan speed(RPM)	/	/	/	/	977	972	967	972	935
	Power input(W)	/	/	/	/	1990	1915	1840	1765	1690
	Air flow(CFM)	/	/	/	/	4320	4272	4224	4146	4067
75	Fan speed(RPM)	/	/	/	981	980	975	970	975	937
	Power input(W)	/	/	/	1998	1915	1843	1770	1695	1620
	Air flow(CFM)	/	/	/	4214	4183	4127	4072	3997	3922
100	Fan speed(RPM)	/	/	986	984	982	977	972	977	938
	Power input(W)	/	/	2000	1900	1800	1730	1660	1590	1520
	Air flow(CFM)	/	/	4129	4052	3974	3905	3835	3771	3707
125	Fan speed(RPM)	/	989	989	987	985	980	975	980	940
	Power input(W)	/	1980	1960	1833	1705	1635	1565	1495	1425
	Air flow(CFM)	/	3953	4065	3927	3789	3719	3648	3579	3509
150	Fan speed(RPM)	1009	991	991	990	988	983	978	983	942
	Power input(W)	2050	1880	1865	1738	1610	1540	1470	1400	1330
	Air flow(CFM)	3830	3778	3891	3748	3605	3532	3460	3386	3312
175	Fan speed(RPM)	1011	993	994	992	990	/	/	/	/
	Power input(W)	1945	1775	1770	1638	1505	/	/	/	/
	Air flow(CFM)	3656	3586	3718	3549	3381	/	/	/	/
200	Fan speed(RPM)	1012	995	997	995	993	/	/	/	/
	Power input(W)	1840	1670	1660	1530	1400	/	/	/	/
	Air flow(CFM)	3481	3394	3517	3337	3157	/	/	/	/
225	Fan speed(RPM)	1014	996	1000	/	/	/	/	/	/
	Power input(W)	1725	1545	1550	/	/	/	/	/	/
	Air flow(CFM)	3292	3148	3316	/	/	/	/	/	/
250	Fan speed(RPM)	1016	998	1002	/	/	/	/	/	/
	Power input(W)	1610	1420	1425	/	/	/	/	/	/
	Air flow(CFM)	3104	2902	3048	/	/	/	/	/	/

Notes:

- Legend: X: Regulation Space of Motor Pulley (mm); N: Number of Turns; ESP: External Static Pressure (Pa);
- PULLEY PITCH Factory set point: The table, no. of turns (N) =1.5;
- Bold data is the performance testing set point;
- Shading data are rated airflow.



10.6 Model: 12.5Ton

ESP(Pa)	N	0	0.25	0.5	0.75	1	1.25	1.5	1.75	2	2.25	2.5
	X	0.5	1	1.5	2	2.5	3	3.5	4	4.5	5	5.5
0	Fan speed(RPM)	857	849	840	828	816	806	795	784	774	772	769
	Power input(W)	3530	3445	3360	3225	3090	3000	2910	2810	2710	2620	2530
	Air flow(CFM)	6773	6718	6662	6575	6487	6395	6302	6230	6158	6103	6049
25	Fan speed(RPM)	858	850	841	829	817	807	796	785	775	772	770
	Power input(W)	3415	3323	3230	3103	2975	2878	2780	2690	2600	2513	2425
	Air flow(CFM)	6571	6503	6435	6354	6272	6176	6079	6004	5929	5872	5815
50	Fan speed(RPM)	859	851	842	830	818	808	797	787	776	773	770
	Power input(W)	3300	3200	3100	2980	2860	2755	2650	2570	2490	2405	2320
	Air flow(CFM)	6368	6288	6208	6133	6057	5956	5856	5778	5699	5641	5582
75	Fan speed(RPM)	861	852	843	831	819	809	798	788	777	774	771
	Power input(W)	3175	3078	2980	2868	2755	2643	2530	2455	2380	2278	2175
	Air flow(CFM)	6151	6069	5987	5901	5814	5711	5608	5534	5461	5363	5265
100	Fan speed(RPM)	862	853	844	832	821	810	799	789	778	775	772
	Power input(W)	3050	2955	2860	2755	2650	2530	2410	2340	2270	2150	2030
	Air flow(CFM)	5933	5850	5766	5669	5571	5465	5359	5291	5222	5085	4948
125	Fan speed(RPM)	863	854	845	833	822	811	800	790	779	776	773
	Power input(W)	2900	2800	2700	2583	2465	2358	2250	2183	2115	1983	1850
	Air flow(CFM)	5645	5538	5432	5361	5290	5179	5067	4977	4887	4694	4500
150	Fan speed(RPM)	864	855	846	834	823	812	801	791	780	777	774
	Power input(W)	2800	2700	2600	2475	2350	2245	2140	2075	2010	1860	1710
	Air flow(CFM)	5456	5347	5238	5169	5101	4978	4856	4754	4652	4398	4144
175	Fan speed(RPM)	865	856	847	835	824	813	802	792	781	778	774
	Power input(W)	2635	2535	2435	2323	2210	2103	1995	1925	1855	1713	1570
	Air flow(CFM)	5187	5066	4946	4870	4794	4656	4519	4397	4275	4031	3788
200	Fan speed(RPM)	866	857	848	836	825	814	804	793	782	/	/
	Power input(W)	2470	2370	2270	2170	2070	1960	1850	1775	1700	/	/
	Air flow(CFM)	4917	4786	4654	4571	4488	4335	4182	4040	3898	/	/
225	Fan speed(RPM)	868	859	849	837	826	815	805	794	783	/	/
	Power input(W)	2295	2203	2110	2000	1890	1788	1685	1608	1530	/	/
	Air flow(CFM)	4575	4434	4293	4187	4082	3922	3763	3622	3481	/	/
250	Fan speed(RPM)	869	860	850	838	827	816	806	795	784	/	/
	Power input(W)	2120	2035	1950	1830	1710	1615	1520	1440	1360	/	/
	Air flow(CFM)	4232	4082	3932	3804	3676	3510	3344	3204	3064	/	/
275	Fan speed(RPM)	870	861	851	839	828	/	/	/	/	/	/
	Power input(W)	1950	1855	1760	1675	1590	/	/	/	/	/	/
	Air flow(CFM)	3816	3674	3533	3423	3314	/	/	/	/	/	/

Notes:

- Legend: X: Regulation Space of Motor Pulley (mm); N: Number of Turns; ESP: External Static Pressure (Pa);
- PULLEY PITCH Factory set point: The table, no. of turns (N) =1.5;
- Bold data is the performance testing set point;
- Shading data are rated airflow.

10.7 Model: 15Ton

ESP(Pa)	N	0	0.25	0.5	0.75	1	1.25	1.5	1.75	2
	X	0.5	1	1.5	2	2.5	3	3.5	4	4.5
0	Fan speed(RPM)	/	/	1008	999	989	979	969	959	949
	Power input(W)	/	/	5146	4968	4790	4575	4360	4155	3950
	Air flow(CFM)	/	/	7928	7867	7805	7686	7566	7452	7338
25	Fan speed(RPM)	/	/	1014	1003	991	983	974	964	953
	Power input(W)	/	/	5043	4824	4605	4418	4230	4025	3820
	Air flow(CFM)	/	/	7791	7691	7592	7473	7353	7239	7124
50	Fan speed(RPM)	/	1022	1020	1006	993	986	979	968	957
	Power input(W)	/	4954	4940	4680	4420	4260	4100	3895	3690
	Air flow(CFM)	/	7700	7653	7516	7379	7259	7139	7025	6910
75	Fan speed(RPM)	1031	1026	1022	1009	995	989	982	971	960
	Power input(W)	4870	4810	4750	4495	4240	4088	3935	3745	3555
	Air flow(CFM)	7622	7529	7436	7313	7191	7048	6904	6790	6675
100	Fan speed(RPM)	1035	1028	1021	1008	995	988	982	971	959
	Power input(W)	4770	4665	4560	4310	4060	3915	3770	3595	3420
	Air flow(CFM)	7475	7347	7219	7111	7002	6836	6669	6554	6439
125	Fan speed(RPM)	1050	1044	1039	1026	1013	1006	998	990	981
	Power input(W)	4510	4440	4370	4123	3875	3760	3645	3465	3285
	Air flow(CFM)	7113	7046	6979	6844	6708	6571	6434	6297	6159
150	Fan speed(RPM)	1060	1056	1052	1039	1026	1021	1015	1005	995
	Power input(W)	4350	4290	4230	4005	3780	3695	3610	3410	3210
	Air flow(CFM)	6899	6863	6828	6679	6531	6411	6291	6134	5976
175	Fan speed(RPM)	1070	1065	1060	1049	1039	1032	1025	1017	1008
	Power input(W)	4170	4078	3985	3808	3630	3518	3405	3248	3090
	Air flow(CFM)	6658	6609	6559	6419	6279	6161	6043	5859	5675
200	Fan speed(RPM)	1082	1074	1067	1059	1051	1044	1036	1028	1020
	Power input(W)	3990	3865	3740	3610	3480	3340	3200	3085	2970
	Air flow(CFM)	6418	6354	6291	6159	6027	5911	5794	5584	5375
225	Fan speed(RPM)	1089	1082	1074	1065	1056	1048	1040	1033	1027
	Power input(W)	3855	3728	3600	3455	3310	3180	3050	2928	2805
	Air flow(CFM)	6194	6108	6022	5879	5736	5600	5464	5269	5075
250	Fan speed(RPM)	1097	1089	1082	1072	1061	1053	1044	1038	1033
	Power input(W)	3720	3590	3460	3300	3140	3020	2900	2770	2640
	Air flow(CFM)	5971	5862	5754	5600	5446	5289	5133	4954	4776
275	Fan speed(RPM)	1104	1095	1086	1076	1065	/	/	/	/
	Power input(W)	3595	3438	3280	3115	2950	/	/	/	/
	Air flow(CFM)	5705	5585	5464	5308	5151	/	/	/	/
300	Fan speed(RPM)	1112	/	/	/	/	/	/	/	/
	Power input(W)	3470	/	/	/	/	/	/	/	/
	Air flow(CFM)	5439	/	/	/	/	/	/	/	/
325	Fan speed(RPM)	1112	/	/	/	/	/	/	/	/
	Power input(W)	3470	/	/	/	/	/	/	/	/
	Air flow(CFM)	5439	/	/	/	/	/	/	/	/

Notes:

- Legend: X: Regulation Space of Motor Pulley (mm); N: Number of Turns; ESP: External Static Pressure (Pa);
- PULLEY PITCH Factory set point: The table, no. of turns (N)=1.5;
- Bold data is the performance testing set point;
- Shading data are rated airflow.



10.8Model: 17.5Ton

ESP(Pa)	N	0	0.25	0.5	0.75	1	1.25	1.5	1.75	2	2.25	2.5
	X	0.5	1	1.5	2	2.5	3	3.5	4	4.5	5	5.5
0	Fan speed(RPM)	/	/	994	987	980	971	961	953	944	936	927
	Power input(W)	/	/	4751	4857	4962	4643	4323	4216	4109	3960	3811
	Air flow(CFM)	/	/	9837	9896	9955	9722	9489	9498	9507	9346	9185
25	Fan speed(RPM)	/	/	994	988	981	972	963	954	946	937	928
	Power input(W)	/	/	4580	4683	4787	4494	4202	4078	3955	3809	3664
	Air flow(CFM)	/	/	9575	9635	9695	9506	9317	9264	9211	9041	8871
50	Fan speed(RPM)	1010	1003	995	988	982	973	965	956	947	939	930
	Power input(W)	4581	4495	4408	4510	4612	4346	4080	3940	3800	3659	3517
	Air flow(CFM)	9591	9451	9312	9373	9434	9290	9145	9030	8915	8736	8557
75	Fan speed(RPM)	1012	1004	997	990	983	975	966	958	949	940	931
	Power input(W)	4392	4313	4235	4338	4442	4181	3920	3777	3635	3495	3356
	Air flow(CFM)	9307	9153	8998	9067	9136	8999	8861	8729	8597	8421	8246
100	Fan speed(RPM)	1013	1005	998	991	984	976	968	959	951	942	933
	Power input(W)	4202	4132	4061	4166	4271	4015	3759	3614	3469	3332	3194
	Air flow(CFM)	9024	8854	8683	8761	8839	8708	8578	8429	8279	8107	7934
125	Fan speed(RPM)	1015	1007	999	992	985	977	969	961	952	943	934
	Power input(W)	4005	3934	3864	3967	4071	3810	3550	3404	3258	3127	2996
	Air flow(CFM)	8684	8510	8336	8421	8507	8350	8194	8027	7860	7684	7507
150	Fan speed(RPM)	1018	1009	1000	994	987	979	971	962	954	945	935
	Power input(W)	3807	3737	3667	3769	3870	3605	3340	3193	3046	2922	2797
	Air flow(CFM)	8345	8167	7989	8082	8175	7992	7809	7625	7441	7261	7081
175	Fan speed(RPM)	1019	1011	1002	995	988	980	972	964	955	946	937
	Power input(W)	3570	3509	3448	3548	3649	3374	3100	2950	2801	2682	2564
	Air flow(CFM)	7899	7719	7539	7648	7757	7518	7279	7093	6907	6715	6522
200	Fan speed(RPM)	1021	1012	1004	998	992	983	974	965	957	947	938
	Power input(W)	3332	3281	3229	3328	3427	3143	2859	2707	2555	2443	2330
	Air flow(CFM)	7454	7272	7090	7215	7339	7044	6748	6561	6374	6169	5963
225	Fan speed(RPM)	1033	1019	1006	1000	994	/	/	/	/	/	/
	Power input(W)	3042	3135	3229	3128	3026	/	/	/	/	/	/
	Air flow(CFM)	6817	6953	7090	6696	6303	/	/	/	/	/	/
250	Fan speed(RPM)	1045	/	/	/	/	/	/	/	/	/	/
	Power input(W)	2751	/	/	/	/	/	/	/	/	/	/
	Air flow(CFM)	6180	/	/	/	/	/	/	/	/	/	/

Notes:

1. Legend: X: Regulation Space of Motor Pulley (mm); N: Number of Turns; ESP: External Static Pressure (Pa);
2. PULLEY PITCH Factory set point: The table, no. of turns (N) =1.5;
3. Bold data is the performance testing set point;
4. Shading data are rated airflow.

10.9 Model: 20Ton

ESP (Pa)	N	0	0.25	0.5	0.75	1	1.25	1.5	1.75	2	2.25	2.5	2.75	3
	X	0.5	1	1.5	2	2.5	3	3.5	4	4.5	5	5.5	6	6.5
0	Fan speed(RPM)	/	/	/	/	1194	1181	1168	1154	1140	1127	1113	1098	1081
	Power input(W)	/	/	/	/	6951	6710	6468	6266	6063	5831	5599	5422	5188
	Air flow(CFM)	/	/	/	/	11210	11104	10997	10872	10746	10623	10499	10306	10078
25	Fan speed(RPM)	/	/	/	/	1195	1182	1169	1155	1141	1128	1114	1100	1083
	Power input(W)	/	/	/	/	6756	6531	6306	6103	5901	5671	5442	5255	5057
	Air flow(CFM)	/	/	/	/	10982	10890	10798	10668	10539	10398	10258	10068	9892
50	Fan speed(RPM)	/	/	/	1214	1196	1183	1170	1156	1142	1129	1115	1101	1084
	Power input(W)	/	/	/	6944	6561	6352	6143	5941	5738	5512	5285	5088	4926
	Air flow(CFM)	/	/	/	10877	10754	10676	10599	10465	10332	10174	10016	9829	9705
75	Fan speed(RPM)	/	/	/	1214	1197	1184	1171	1157	1143	1130	1116	1102	1085
	Power input(W)	/	/	/	6738	6390	6180	5970	5754	5539	5328	5118	5069	4748
	Air flow(CFM)	/	/	/	10628	10540	10453	10367	10207	10047	9898	9749	9807	9403
100	Fan speed(RPM)	/	1240	1228	1215	1198	1185	1172	1158	1145	1131	1117	1103	1087
	Power input(W)	/	6941	6765	6532	6218	6008	5797	5568	5339	5145	4950	5049	4570
	Air flow(CFM)	/	10582	10491	10378	10326	10230	10135	9948	9761	9622	9483	9785	9102
125	Fan speed(RPM)	/	1241	1230	1215	1199	1186	1173	1159	1146	1131	1117	1105	1091
	Power input(W)	/	6753	6659	6367	6068	5866	5663	5441	5218	5013	4808	4570	4351
	Air flow(CFM)	/	10357	10349	10170	10113	10017	9922	9753	9584	9435	9285	9024	8815
150	Fan speed(RPM)	1258	1242	1230	1216	1202	1189	1175	1162	1149	1134	1120	1105	1091
	Power input(W)	6736	6565	6360	6158	5820	5611	5401	5180	4958	4769	4579	4327	4141
	Air flow(CFM)	10287	10132	10049	9952	9818	9692	9566	9395	9224	9069	8915	8599	8418
175	Fan speed(RPM)	1261	1244	1232	1218	1204	1190	1177	1163	1149	1135	1121	1106	1093
	Power input(W)	6511	6332	6169	5929	5607	5391	5175	4953	4731	4545	4358	4107	3925
	Air flow(CFM)	10042	9864	9794	9650	9524	9377	9231	9046	8861	8699	8537	8243	8045
200	Fan speed(RPM)	1263	1245	1233	1221	1205	1192	1179	1164	1150	1136	1123	1106	1094
	Power input(W)	6285	6099	5977	5700	5394	5172	4949	4727	4504	4321	4137	3887	3709
	Air flow(CFM)	9798	9597	9540	9347	9230	9063	8896	8697	8497	8328	8158	7887	7672
225	Fan speed(RPM)	1264	1248	1235	1222	1207	1194	1181	1166	1152	1138	1124	1110	1096
	Power input(W)	6046	5871	5696	5451	5160	4923	4686	4461	4237	4049	3861	3624	3433
	Air flow(CFM)	9505	9301	9183	9019	8877	8693	8508	8291	8074	7871	7669	7387	7138
250	Fan speed(RPM)	1265	1251	1237	1224	1209	1196	1183	1169	1154	1140	1126	1113	1099
	Power input(W)	5807	5643	5415	5201	4925	4674	4422	4196	3969	3777	3585	3361	3157
	Air flow(CFM)	9212	9004	8826	8691	8524	8322	8120	7885	7650	7415	7180	6887	6605
275	Fan speed(RPM)	1267	1253	1239	1226	1211	1198	1185	1171	1157	1144	1130	1117	1094
	Power input(W)	5523	5350	5120	4872	4585	4322	4059	3812	3564	3331	3098	2800	2662
	Air flow(CFM)	8831	8594	8380	8204	8010	7740	7470	7173	6876	6487	6099	5562	5395
300	Fan speed(RPM)	1269	1254	1242	1228	1213	1201	1188	1174	1160	1147	1134	1120	1088
	Power input(W)	5238	5056	4825	4542	4245	3971	3696	3428	3159	2885	2611	2239	2167
	Air flow(CFM)	8450	8184	7933	7717	7495	7157	6819	6460	6102	5560	5018	4237	4186
325	Fan speed(RPM)	1272	1258	1245	1233	1218	1206	1193	/	/	/	/	/	/
	Power input(W)	4892	4650	4334	3987	3707	3334	2961	/	/	/	/	/	/
	Air flow(CFM)	7955	7559	7136	6775	6406	5820	5234	/	/	/	/	/	/
350	Fan speed(RPM)	1276	1262	1248	1235	1223	/	/	/	/	/	/	/	/
	Power input(W)	4546	4243	3842	3731	3169	/	/	/	/	/	/	/	/
	Air flow(CFM)	7459	6935	6339	6285	5318	/	/	/	/	/	/	/	/
375	Fan speed(RPM)	1280	1267	1254	/	/	/	/	/	/	/	/	/	/
	Power input(W)	3982	3457	3371	/	/	/	/	/	/	/	/	/	/
	Air flow(CFM)	6465	5433	5387	/	/	/	/	/	/	/	/	/	/
400	Fan speed(RPM)	1284	/	/	/	/	/	/	/	/	/	/	/	/
	Power input(W)	3417	/	/	/	/	/	/	/	/	/	/	/	/
	Air flow(CFM)	5471	/	/	/	/	/	/	/	/	/	/	/	/

Notes:

- Legend: X: Regulation Space of Motor Pulley (mm); N: Number of Turns; ESP: External Static Pressure (Pa);
- PULLEY PITCH Factory set point: The table, no. of turns (N) =1.5;
- Bold data is the performance testing set point;
- Shading data are rated airflow.

10.10 Model: 25Ton

ESP (Pa)	N	0	0.25	0.5	0.75	1	1.25	1.5	1.75	2	2.25	2.5	2.75	3
	X	0.5	1	1.5	2	2.5	3	3.5	4	4.5	5	5.5	6	6.5
0	Fan speed(RPM)	1075	1059	1044	1034	1026	1009	1002	985	973	963	934	939	925
	Power input(W)	6962	6840	6589	6382	6068	5930	5651	5544	5232	5085	4765	4893	4734
	Air flow(CFM)	12304	12345	12115	12068	11907	11717	11587	11472	11269	11177	10868	10894	10757
25	Fan speed(RPM)	1075	1060	1041	1035	1027	1010	1003	986	974	964	935	939	926
	Power input(W)	6750	6663	6363	6203	5914	5736	5487	5374	5065	4905	4632	4740	4597
	Air flow(CFM)	12052	12092	11849	11797	11645	11431	11322	11191	10982	10879	10572	10610	10471
50	Fan speed(RPM)	1074	1061	1038	1036	1028	1011	1004	987	975	965	936	940	927
	Power input(W)	6538	6485	6137	6023	5759	5541	5323	5203	4898	4724	4498	4587	4459
	Air flow(CFM)	11801	11838	11583	11527	11383	11144	11058	10909	10695	10581	10276	10326	10185
75	Fan speed(RPM)	1075	1062	1040	1036	1029	1011	1004	987	976	966	937	941	928
	Power input(W)	6391	6301	5903	5842	5573	5329	5152	5019	4698	4524	4304	4410	4282
	Air flow(CFM)	11575	11558	11249	11218	11055	10820	10745	10585	10345	10217	9914	9964	9825
100	Fan speed(RPM)	1075	1063	1041	1036	1030	1012	1005	988	977	967	937	942	928
	Power input(W)	6243	6117	5668	5660	5387	5116	4980	4834	4498	4324	4110	4233	4104
	Air flow(CFM)	11350	11278	10915	10910	10728	10496	10432	10260	9995	9853	9552	9602	9465
125	Fan speed(RPM)	1076	1063	1044	1037	1030	1013	1005	989	979	968	938	943	929
	Power input(W)	6089	5904	5425	5441	5178	4900	4790	4626	4292	4114	3928	4040	3911
	Air flow(CFM)	11019	10945	10566	10567	10361	10123	10054	9870	9598	9432	9155	9168	9021
150	Fan speed(RPM)	1077	1063	1047	1037	1031	1015	1005	990	980	969	939	944	930
	Power input(W)	5934	5690	5181	5222	4969	4683	4600	4418	4085	3904	3746	3846	3717
	Air flow(CFM)	10688	10612	10217	10224	9994	9749	9677	9480	9201	9010	8758	8735	8577
175	Fan speed(RPM)	1077	1064	1047	1038	1032	1015	1006	991	981	969	939	944	931
	Power input(W)	5613	5449	4984	4995	4746	4455	4382	4203	3862	3683	3548	3645	3512
	Air flow(CFM)	10300	10229	9839	9828	9590	9294	9245	9031	8703	8496	8259	8225	8064
200	Fan speed(RPM)	1078	1065	1048	1039	1033	1016	1006	992	982	969	940	945	932
	Power input(W)	5292	5207	4786	4768	4522	4226	4163	3987	3638	3462	3349	3443	3307
	Air flow(CFM)	9913	9847	9462	9432	9186	8838	8812	8581	8206	7983	7760	7715	7551
225	Fan speed(RPM)	1079	1066	1051	1040	1034	1017	1007	993	983	970	941	946	932
	Power input(W)	5294	4968	4527	4522	4299	3990	3958	3758	3408	3240	3135	3203	3078
	Air flow(CFM)	9875	9378	8936	8922	8670	8306	8296	8037	7615	7383	7169	7025	6863
250	Fan speed(RPM)	1080	1067	1053	1042	1034	1018	1008	994	984	970	942	947	933
	Power input(W)	5295	4728	4267	4275	4076	3753	3753	3528	3177	3018	2921	2962	2849
	Air flow(CFM)	9837	8910	8410	8412	8154	7775	7780	7492	7024	6784	6578	6335	6175
275	Fan speed(RPM)	1082	1068	1050	1042	1035	1019	1009	995	985	971	942	948	934
	Power input(W)	4879	4488	4013	4034	3825	3496	3486	3341	2975	2803	2717	2792	2530
	Air flow(CFM)	8972	8391	7852	7864	7575	7096	7053	6824	6335	5996	5844	5744	5204
300	Fan speed(RPM)	1084	1070	1047	1043	1035	1021	1010	995	986	973	943	949	935
	Power input(W)	4463	4248	3759	3793	3574	3239	3219	3153	2773	2587	2512	2621	2210
	Air flow(CFM)	8107	7871	7293	7316	6996	6418	6325	6156	5647	5209	5110	5152	4234
325	Fan speed(RPM)	1084	1072	1054	1046	1036	1023	1010	997	986	/	/	/	/
	Power input(W)	4219	3996	3636	3538	3313	3089	3219	2818	2773	/	/	/	/
	Air flow(CFM)	7663	7324	6813	6603	6221	5896	6325	5316	5647	/	/	/	/
350	Fan speed(RPM)	1085	1073	1061	1050	1038	1025	1011	/	/	/	/	/	/
	Power input(W)	3975	3744	3513	3282	3051	2940	3024	/	/	/	/	/	/
	Air flow(CFM)	7219	6776	6332	5889	5445	5375	5815	/	/	/	/	/	/
375	Fan speed(RPM)	1087	1074	1062	/	/	/	/	/	/	/	/	/	/
	Power input(W)	3708	3474	3241	/	/	/	/	/	/	/	/	/	/
	Air flow(CFM)	6428	5990	5551	/	/	/	/	/	/	/	/	/	/
400	Fan speed(RPM)	1088	/	/	/	/	/	/	/	/	/	/	/	/
	Power input(W)	3440	/	/	/	/	/	/	/	/	/	/	/	/
	Air flow(CFM)	5637	/	/	/	/	/	/	/	/	/	/	/	/

Notes:

- Legend: X: Regulation Space of Motor Pulley (mm); N: Number of Turns; ESP: External Static Pressure (Pa);
- PULLEY PITCH Factory set point: The table, no. of turns (N) =1.5;
- Bold data is the performance testing set point;
- Shading data are rated airflow.

10.11 Model: 30Ton

ESP (Pa)	N	0	0.25	0.5	0.75	1	1.25	1.5	1.75	2	2.25	2.5	2.75	3
	X	0.5	1	1.5	2	2.5	3	3.5	4	4.5	5	5.5	6	6.5
0	Fan speed(RPM)	/	/	/	/	/	/	1106	1090	1074	1053	1032	1027	1022
	Power input(W)	/	/	/	/	/	/	8203	7899	7595	7256	6917	6894	6872
	Air flow(CFM)	/	/	/	/	/	/	13393	13210	13026	12794	12563	12499	12434
25	Fan speed(RPM)	/	/	/	/	1133	1133	1106	1090	1074	1053	1032	1027	1022
	Power input(W)	/	/	/	/	9142	9142	8010	7702	7394	7078	6761	6736	6710
	Air flow(CFM)	/	/	/	/	13735	13735	13243	13044	12845	12605	12366	12307	12248
50	Fan speed(RPM)	/	/	/	/	1135	1135	1108	1092	1076	1055	1034	1029	1023
	Power input(W)	/	/	/	/	8664	8664	7736	7427	7118	6828	6537	6509	6480
	Air flow(CFM)	/	/	/	/	13304	13304	12902	12690	12479	12234	11990	11937	11884
75	Fan speed(RPM)	/	/	/	/	1137	1137	1109	1094	1078	1056	1035	1030	1025
	Power input(W)	/	/	/	/	8425	8425	7490	7160	6831	6544	6258	6241	6225
	Air flow(CFM)	/	/	/	/	13089	13089	12619	12384	12149	11897	11644	11591	11539
100	Fan speed(RPM)	/	/	1153	1146	1138	1138	1110	1095	1080	1058	1036	1031	1026
	Power input(W)	/	/	9127	8545	8186	8186	7244	6893	6543	6261	5978	5974	5970
	Air flow(CFM)	/	/	13410	12993	12873	12873	12336	12078	11820	11558	11296	11245	11193
125	Fan speed(RPM)	/	/	1155	1148	1140	1140	1112	1097	1083	1060	1038	1033	1028
	Power input(W)	/	/	8920	8330	7963	7963	7007	6642	6278	6012	5746	5733	5720
	Air flow(CFM)	/	/	13149	12713	12576	12576	12002	11730	11457	11193	10929	10849	10769
150	Fan speed(RPM)	1172	1165	1157	1150	1142	1142	1113	1099	1085	1062	1039	1035	1030
	Power input(W)	9645	9015	8712	8069	7741	7080	6770	6391	6012	5763	5513	5492	5470
	Air flow(CFM)	13274	12898	12887	12386	12278	11362	11669	11381	11094	10827	10560	10451	10342
175	Fan speed(RPM)	1172	1166	1158	1152	1144	1144	1114	1100	1087	1064	1041	1036	1032
	Power input(W)	9364	8711	8385	7748	7426	7426	6467	6083	5699	5468	5236	5210	5184
	Air flow(CFM)	12944	12550	12522	12006	11884	11884	11246	10916	10587	10317	10047	9928	9809
200	Fan speed(RPM)	1173	1167	1159	1153	1145	1145	1116	1102	1088	1065	1042	1038	1033
	Power input(W)	9083	8407	8058	7415	7111	7111	6164	5775	5387	5173	4959	4928	4897
	Air flow(CFM)	12615	12175	12156	11586	11489	11489	10822	10450	10078	9804	9530	9402	9273
225	Fan speed(RPM)	1174	1168	1161	1155	1147	1147	1117	1104	1091	1067	1044	1039	1035
	Power input(W)	8884	8145	7732	7083	6772	6772	5812	5408	5004	4804	4603	4562	4520
	Air flow(CFM)	12356	11835	11735	11139	11016	11016	10298	9875	9452	9175	8898	8708	8518
250	Fan speed(RPM)	1176	1172	1162	1156	1148	1148	1119	1106	1093	1069	1046	1041	1036
	Power input(W)	8686	7877	7406	6744	6433	6433	5460	5041	4622	4436	4250	4197	4145
	Air flow(CFM)	12097	11466	11313	10604	10543	10543	9773	9298	8823	8542	8262	8009	7756
275	Fan speed(RPM)	1187	1176	1168	1159	1149	1149	1121	1108	1095	1071	1047	1042	1038
	Power input(W)	8462	7587	7067	6394	6081	6081	5095	4722	4348	4159	3970	3834	3697
	Air flow(CFM)	11693	10973	10835	10015	9895	9895	8955	8500	8044	7732	7420	7014	6608
300	Fan speed(RPM)	1182	1175	1166	1159	1150	1150	1123	1109	1096	1072	1048	1044	1039
	Power input(W)	8114	7246	6711	6082	5721	5721	4730	4402	4075	3883	3691	3469	3247
	Air flow(CFM)	11270	10508	10253	9488	9195	9195	8138	7701	7265	6919	6574	6010	5447
325	Fan speed(RPM)	1185	1178	1169	1161	1152	1138	1124	/	/	/	/	/	/
	Power input(W)	7721	6884	6379	5782	5453	4990	4527	/	/	/	/	/	/
	Air flow(CFM)	10729	9983	9745	8998	8723	8211	7700	/	/	/	/	/	/
350	Fan speed(RPM)	1188	1182	1171	1164	1154	1139	1125	/	/	/	/	/	/
	Power input(W)	7328	6237	6046	5347	5185	4755	4324	/	/	/	/	/	/
	Air flow(CFM)	10187	8913	9238	8209	8250	7756	7262	/	/	/	/	/	/
375	Fan speed(RPM)	1191	1183	1173	1165	1155	1140	1126	/	/	/	/	/	/
	Power input(W)	7114	6130	5596	5121	4916	4576	4236	/	/	/	/	/	/
	Air flow(CFM)	9916	8778	8439	7810	7715	7353	6991	/	/	/	/	/	/
400	Fan speed(RPM)	1195	1185	1175	1166	1156	1141	1127	/	/	/	/	/	/
	Power input(W)	6899	6022	5146	4896	4647	4397	4148	/	/	/	/	/	/
	Air flow(CFM)	9645	8643	7640	7410	7180	6951	6721	/	/	/	/	/	/

Notes:

- Legend: X: Regulation Space of Motor Pulley (mm); N: Number of Turns; ESP: External Static Pressure (Pa);
- PULLEY PITCH Factory set point: The table, no. of turns (N) = 1.5;
- Bold data is the performance testing set point;
- Shading data are rated airflow.

11. Refrigerant Cycle Diagram

11.1 6.2&7.5 ton:

Cooling only type

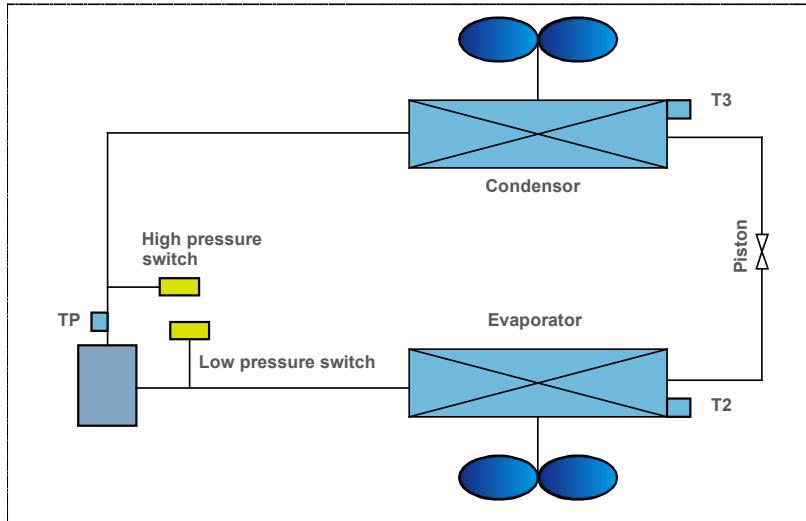

TP: Compressor discharge temperature sensor in system

T2: Indoor coil temperature sensor in system

T3: Outdoor coil temperature sensor in system

11.2 8.5,10,12.5,15,17.5&20 ton:

Cooling only type:

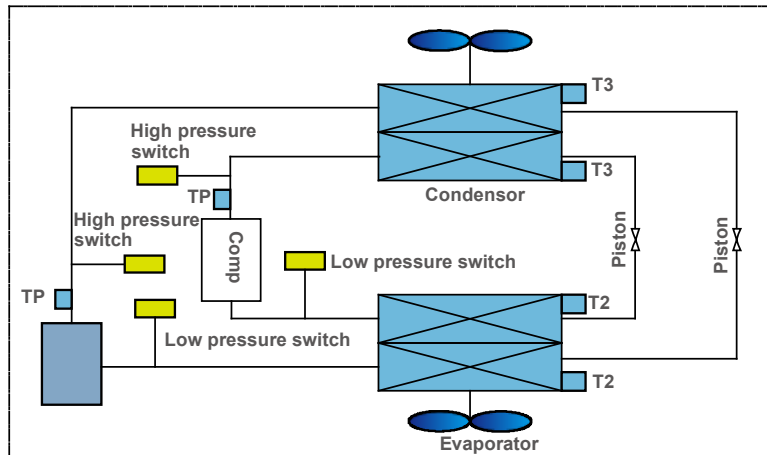

11.3 25&30 ton:

Cooling only type

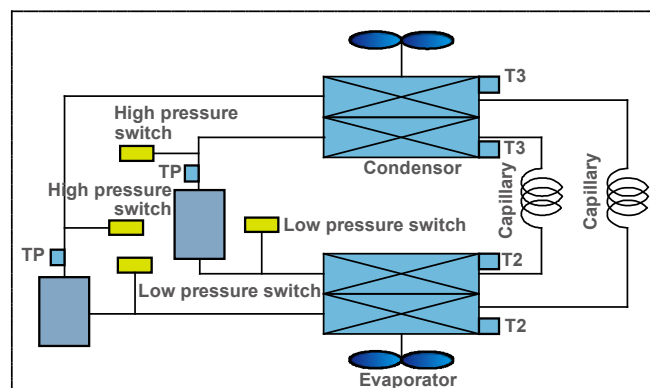

TP: Compressor discharge temperature sensor in system A and B

T2: Indoor coil temperature sensor in system A and B

T3: Outdoor coil temperature sensor in system A and B

12. Operation Limit

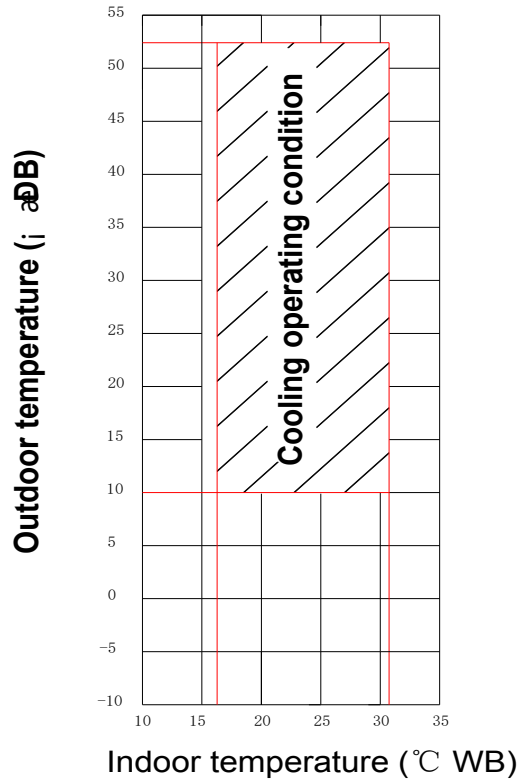

Model	Temperature	Outdoor temperature	Indoor temperature
	Cooling only mode		10°C~52°C

Note:

Room relative humidity less than 80% . If the unit operates in excess of this figure, the surface of the unit may attract condensation.

13. Installation

13.1 Lifting

Rigging cables should have adequate capability to resist 3 times weight of unit. Before lift, please check and ensure that hooks are holding tightly to unit and lifting angles are no less than 60°.

Cloth material or hard-paper should be padded in the contact place between unit and rigging cable. Rigging cable should be entwined a round at the hook for prevent danger by cable slip because of weight unbalance. During lifting, anyone forbidden lingering under the lifting unit.

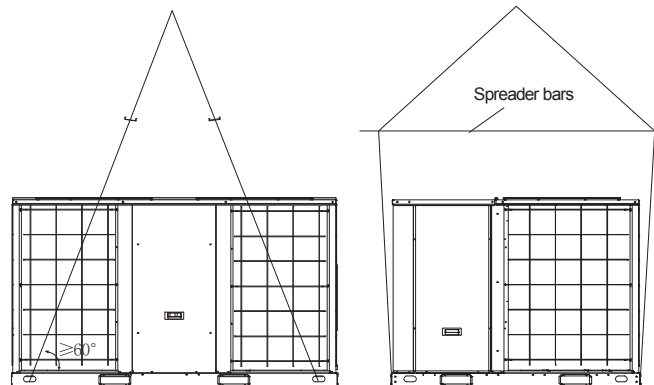

13.2 Service Space

1. The recommended clearances for single-unit installations are illustrated in following *Fig.*

These minimum requirements are not only an important consideration when determining unit placement, but they are also essential to ensure adequate serviceability, maximum capacity, and peak operating efficiency. 2. Any reduction of the unit clearances indicated in these illustrations may result in condenser coil starvation or the recirculation of warm condenser air. Actual clearances which appear to be inadequate should be reviewed with a local engineer.

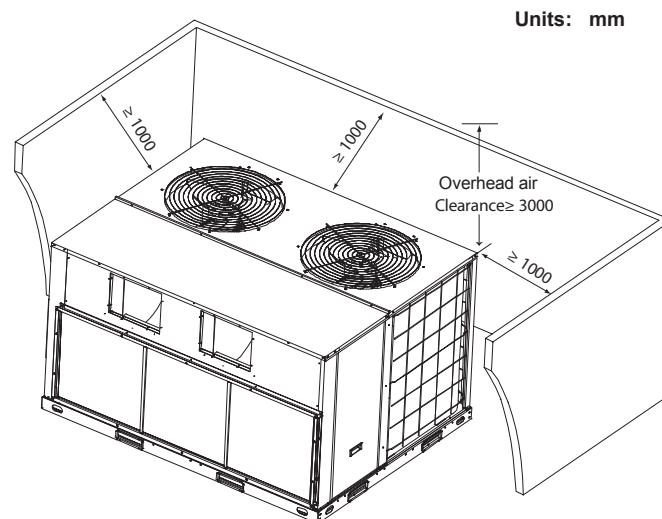

13.3 Rooftop -- units

For roof top applications using a field fabricated frame and ducts, according to the following procedure:

- 1) The frame must be located and secured by bolting or welding to the roof. Flashing is required.
- 2) The hole in the roof must be prepared in advance of installing the unit.
- 3) Secure the ducts to the roof.

- 4) Place the unit on the frame or roof curb.
- 5) Secure the unit to the frame or roof curb.
- 6) Insulate any ductwork outside of the structure with at least two (2) inches of insulation and then weatherproof. There must be a weatherproof seal where the duct enters the structure.
- 7) Complete the installation according to the instructions.

Typical rooftop application with frame:

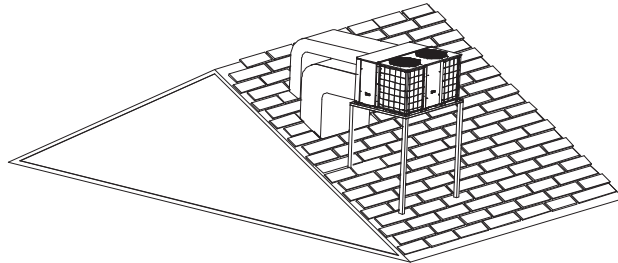

13.4 Ground Level -- Horizontal Units

For ground level installations, the unit should be positioned on a pad the size of the unit or larger. The unit must be level on the pad. The pad must not come in contact with the structure. Be sure the outdoor portion of the supply and return air ducts are as short as possible.

Installation according to the following procedure:

- 1) Place the unit on the pad.
- 2) Attach the supply and return air ducts to the unit.
- 3) Insulate any ductwork outside of the structure with at least 2 inches of insulation and weatherproof. There must be a weatherproof seal where the duct enters the structure.
- 4) Complete the installation according to the instructions.

Typical ground level application:

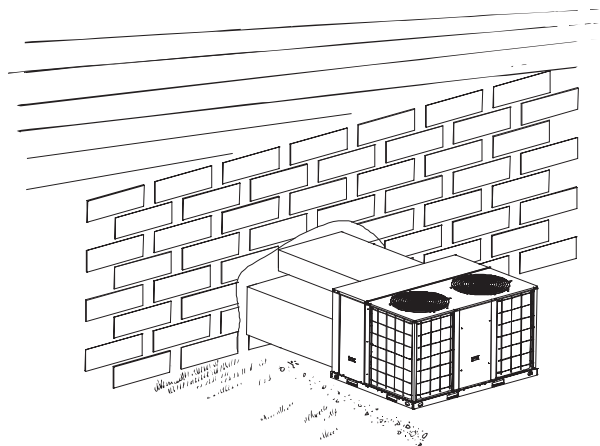

13.5 Installation of condensate drain piping

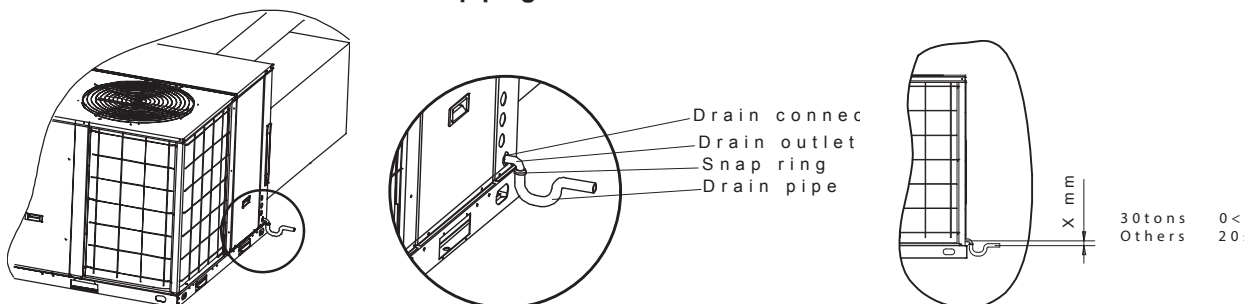

13.6 Ductwork

1. Attaching horizontal ductwork to unit

- 1) All conditioned air ductwork should be insulated to minimize heating and cooling duct losses. Use a minimum of two inches of insulation with a vapor barrier. The outside ductwork must be weatherproofed between the unit and the building.
- 2) When attaching ductwork to a horizontal unit, provide a flexible watertight connection to prevent noise transmission from the unit to the ducts. The flexible connection must be indoors and made out of heavy canvas.

Note:

Do not draw the canvas taut between the solid ducts.

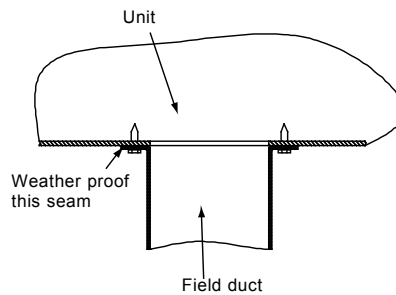

13.7 Wiring provision

Field wiring

The units are internally wired at the factory according to generally accepted electrical technology.

Required field wiring

Main power wiring to the unit control wiring between the control center and the unit, and earth wiring are required in the field.

Required components

The following components are required: main power fuse, conduit coupling, and field supplied room thermostat.

Wire and fuse size selection for main power source.

Wire and fuse size should be selected in accordance with national standard, taking the designed maximum current shall be the total of the compressor maximum current, condenser fan motor current and evaporator fan motor current (refer to “electrical data”).

Wire size between room thermostat and unit.

The wire size between the room thermostat and the unit should be determined according to the following table, because the 24V power source is applied to the control circuit.

	Wiring length between room thermostat and unit(one way)				
	10m	15m	20m	30m	40m
Minimum wire size(mm ²)	0.5	0.5	0.75	0.75	1.0

14. Wired Controller

14.1 Standard wired controller: KJR-12B/DP (T)-E





Wired Thermostat



1. SAFETY PRECAUTIONS

The following contents are stated on the product and the operation manual, including usage, precautions against personal harm and property loss, and the methods of using the product correctly and safely. After fully understanding the following contents (identifiers and icons), read the text body and observe the following rules.



Identifier description

Identifier	Meaning
 Warning	Means improper handling may lead to personal death or severe injury.
 Caution	Means improper handling may lead to personal injury or property loss.
[Note]: 1. "Harm" means injury, burn and electric shock which need long-term treatment but need no hospitalization 2. "Property loss" means loss of properties and materials.	

■ Icon description

Icon	Meaning
	It indicates forbidding. The forbidden subject-matter is indicated in the icon or by images or characters aside.
	It indicates compulsory implementation. The compulsory subject-matter is indicated in the icon or by images or characters aside.

Warning

 Warning	Delegate installation	Please entrust the distributor or professionals to install the unit. The installers must have the relevant know-how. Improper installation performed by the user without permission may cause fire, electric shock, personal injury or water leakage.
 Usage Warning	Forbid	Do not spray flammable aerosol to the wire controller directly. Otherwise, fire may occur.
	Forbid	Do not operate with wet hands or let water enter the wire controller. Otherwise, electric shock may occur.

2. SUMMARIZE

Usage condition:

- ①. Power supply: 5V DC.
- ②. Operation temperature: -15°C~+43°C.
- ③. Operation humidity: 40%-90%, RH.

3. FUNCTION SUMMARY

Main function:

- ①. Connecting to indoor unit by A, B, C, D, E terminal;
- ②. Button setting action mode.
- ③. LCD display.
- ④. Timer for rest time.

4. NAME AND FUCTION OF INDICATORS ON THE CONTROLLER

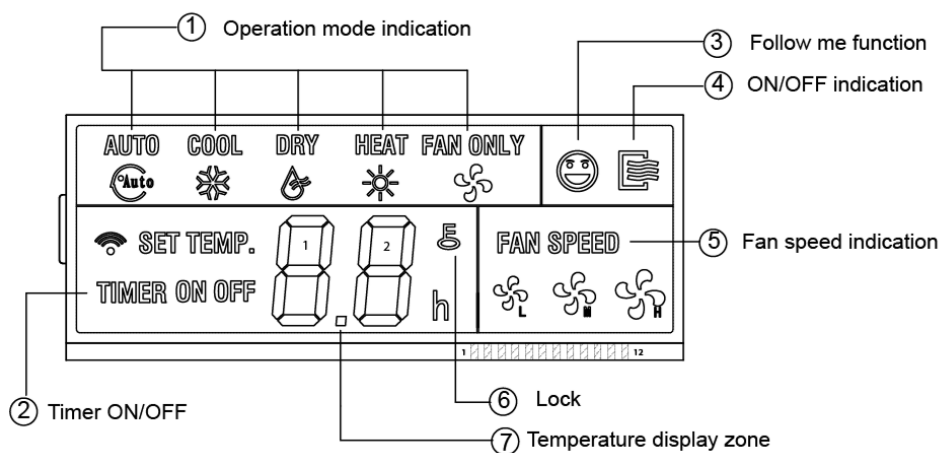

① Operation mode indication:

When press " MODE " button, the following mode can be selected in circle. Auto→Cool →Dry→Heat→ Fan only→Auto. For cooling only model,heat mode is skipped.

② Timer :

When adjust setting on time or only on time is set, the "ON" is lighted.

When adjust setting off time or only off time is set, the "OFF" is lighted. If both 'on' and 'off' timer are set, both the "ON" and "OFF" are lighted.

③ Follow me function:

There is a temperature sensor inside the wire controller, after setting temperature, it will compare the two temperatures, and the space of wire controller will be the same as setting temperature. It is available under cooling, heating, auto mode.

④ ON/OFF indication :

When it is on, the icon display, otherwise it is extinguished.

⑤ Fan speed indication :

There are four fan modes : low, middle, high, auto. For some models, no middle fan then the middle fan is seen as high speed. The function is not suitable for the rooftop package units.

⑥ Lock:

When the " LOCK " button is pressed, the icon appear and other buttons is unable, press again, the icon disappear.

⑦ Temperature display zone:

Generally it displays setting temperature, it can be adjusted by press temperature button ▲ and ▼. But in fan mode, no display here.

5. INSTALLATION METHOD

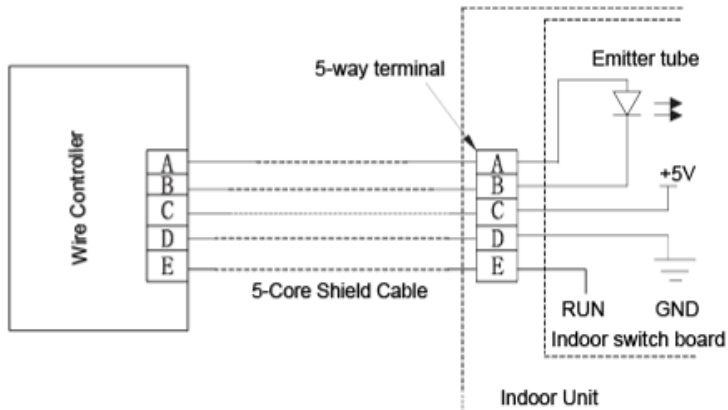

When a wired controller is needed, a small 5-way terminal should be added, fix an infrared emitter with gumwater near the receiver on the switch board. Connect its anode and cathode to A and B, and +5V, GND, RUN to C, D, E on the switch board.

6. NAME AND OPERATION OF THE BUTTON ON THE WIRE CONTROLLER

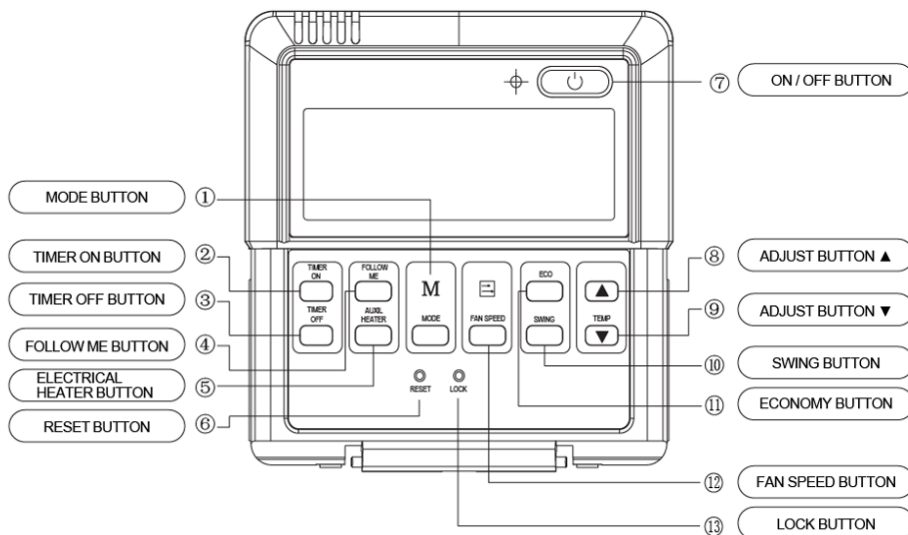

① Mode button:

When press this button, the operation mode change as the following sequence:

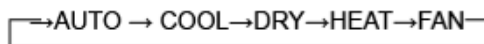

Remark: For the cooling only model, the heating mode is skipped.

② Timer on button :

Press this button, timer on function is active. Then every press, the time increase 0.5h, after 10h, 1h increase after each press. If cancel this Function, just set it to "0.0".

③ Timer off button:

Press this button, timer off function is active. Then every press, the time increase 0.5h, after 10h, per 1h increase after each press. If cancel this function, just set it to "0.0".

④ Follow me button:

When under cool, heat and auto mode, press this button, follow me function is active. Press again, this function is ineffective.

⑤ Electrical heater button :

If press this button in heat mode, electrical heater function become ineffective.

⑥ Reset button(hidden):

Use a 1mm stick to press in the little hole , then the current setting is canceled . The wired controller will enter into original state.

⑦ ON/OFF button:

When in off state, press this button, the indicator is on, the wire controller enter into on state, and send setting information to in door PCB. When in on state, press this button, the indicator is off, and send instruction. If timer on or timer off has been set, it cancel this setting then send instruction to stop the machine.

⑧ Adjust button ▲:

Set indoor temperature up. If press and hold on, it will increase at 1 degree per 0.5 second.

⑨ Adjust button ▼ :

Set indoor temperature down. If press and hold on, it will decrease at 1 degree per 0.5 second.

⑩ Swing button:

First pressing: start swing function; second pressing: stop swing. (Match to some model with swing function).

⑪ Economy operation button:

Press this button, the indoor unit operates in economy mode, press it again, exit this mode (it may be ineffective for some models)

⑫ Fan speed button:

Press this button consecutively, the fan speed will circle as follow:

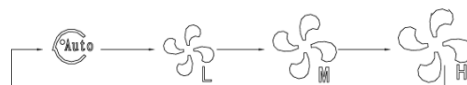

⑬ Lock button (hidden):

When you push the LOCK button, all current settings are locked in and the wire controller does not accept any operation except that of the LOCK button. Use the lock mode when you want to prevent setting from being changed accidentally or play fully. Push the LOCK button again when you want to cancel the LOCK mode.

7. USING METHOD

AUTOMATIC OPERATION

Connect to power, indoor operation lamp flash.

- ①. Press "MODE" button, select " AUTO " ;
- ②. Press the button "▲" and "▼", set temperature you want, generally it is among 17°C~30°C;
- ③. Press " ON/OFF" button, operation lamp is on, the air-conditioner work in auto mode, indoor fan is auto, and can not be changed. Auto is displayed on LCD. Press " ON/OFF" button again to stop.
- ④. Economy operation is valid in auto mode.

COOL/HEAT/FAN MODE OPERATION

- ①. Press "MODE" button, select "COOL", "HEAT" or "FAN ONLY" mode.
- ②. Press temperature adjust button to select setting temp..
- ③. Press "FAN SPEED" button to select high/mid/low/auto.
- ④. Press "ON/OFF" button, indoor unit operation lamp on, it works in selected mode. Press "ON/OFF" button again, it stops to work.

Remark: When in fan mode, no temperature can be set.



DRY OPERATION

- ①. Press " MODE " button, select " DRY " mode.
- ②. Press temperature adjust button to select setting temp.
- ③. Press " ON/OFF " button, indoor unit operation lamp on, it works in dry mode. Press ON/OFF button again, it stops to work.
- ④. In dry mode, economy operation and fan speed are ineffective.

TIMER SETTING

Timer on only:

- ①. Press " TIME ON " button, it display "SET" on LCD, and display " H " and "ON" , it is waiting for timer on setting.
- ②. Press " timer " on button repeatedly to adjust time setting.
- ③. If press this button and hold on, the time will increase at 0.5h, after 10h, it increases at 1h.
- ④. After setting 0.5 second, the wire controller send timer on information, it is finished.

Timer off only:

- ①. Press "TIME OFF " button, it display "SET" on LCD, and display " H " and ON, it is waiting for timer on setting.
- ②. Press "TIME OFF" button repeatedly to adjust time setting.
- ③. If press this button and hold on, the time will increase at 0.5h, after 10h, it increases at 1h.
- ④. After setting 0.5 second, the wire controller send timer off information, it is finished.

TIMER ON AND TIMER OFF BOTH

- ①. Set timer on time as the corresponding step1 and 2.
- ②. Set timer off time as the corresponding step1 and 2.
- ③. Timer off time must be longer than timer on time.
- ④. 0.5 second after setting, the wire controller send information, the setting is finished.

CHANGE TIMER

If there is a timer of changing time to be need, press corresponding button to revise it. If cancel timer, change time to 0.0.

NOTE: The timer time is relative time, that is delay after setting time (i, e: setting time is 8:05 A,M). So when timer is set, the standard time can not be adjusted.

8. TECHNICAL INDICATION AND REQUIREMENT

EMC and EMI comply with the CE certification requirements.

15. Error Code

15.1 Error Code for 6.2&7.5ton

NUM	CODE	LED1(RED)	LED2(YELLOW)	LED3(GREEN)
1	STANDBY	OFF	OFF	ON
2	FUNCTION	ON	ON	ON
3	PHASE-MISSING	FLASH	FLASH	FLASH
	PHASE-ERROR			
4	T1 SENSOR FAILURE	FLASH	FLASH	FLASH
	HIGH PRESSURE PROTECTION			
	VENT PROTECTION			
5	T2 SENSOR FAILURE	FLASH	OFF	FLASH
6	T3 SENSOR FAILURE	OFF	FLASH	FLASH
7	T4 SENSOR FAILURE	ON	FLASH	FLASH
8	T2 EVAPORATOR LOW TEMP. PROTECTION	OFF	FLASH	OFF
9	T2 EVAPORATOR HIGH TEMP. PROTECTION	FLASH	ON	ON
10	T3 CONDENSOR HIGH TEMP. PROTECTION	FLASH	OFF	OFF
11	LINE CONTROLLER INPUT FAILURE	FLASH	FLASH	ON
12	COMPRESSOR OVERCURRENT PROTECTION	OFF	OFF	FLASH
13	COMPRESSOR-INHALING LOW PRESSURE PROTECTION	FLASH	ON	FLASH
14	DEFROST	ON	FLASH	FLASH

Error code for 8.5ton and above

Type	Content	Code	Remarks
Normal	Standby	-----	
Normal	Constraint cool	On	
Normal	Run	10.	
Error	Compressor phase sequence error or phase default	E0	
Error	Outdoor coil sensor is sys. A error	E1	
Error	Outdoor coil sensor is sys. B error	E2	
Error	Overcurrent protection of system A are active 3 times within one hour	E3	Unit shall be power off to recovery
Error	Overcurrent protection of system B are active 3 times within one hour	E4	Unit shall be power off to recovery
Error	Indoor coil sensor is sys. A error	E5	
Error	Indoor coil sensor is sys. B error	E6	
Error	High, low pressure protection or discharge temperature protection of system A reached 3 times	E7	Unit shall be power off to recovery
Error	High, low pressure protection or discharge temperature protection of system B reached 3 times	E8	Unit shall be power off to recovery
Error	Indoor sensor error	E9	
Error	Outdoor ambient sensor error	EA	
Error	Wire controller output error	Eb	
Protection	Overcurrent protection in sys.A	P0	
Protection	Overcurrent protection in sys.B	P1	
Protection	Overcurrent protection for indoor fan	P2	
Protection	Comprehensive protection for outdoor fan	P3	
Protection	Protection for Hi./Lo. pressure or exhaust temp. in sys.A	P4	Comprehensive protection in sys.A
Protection	Protection for Hi./Lo. pressure or exhaust temp. in sys.B	P5	Comprehensive protection in sys.A
Protection	Hi-pressure protection initiated in T2 evaporator stops the outdoor unit fan	P6	
Protection	Hi-pressure protection initiated in T2 evaporator stops the outdoor unit fan and compressor	P7	
Protection	Protection for condenser Hi-temp. in sys.A	P8	
Protection	Protection for condenser Hi-temp. in sys.B	P9	
Protection	Anti-freezing protection for evaporator in sys.A	Pc	
Protection	Anti-freezing protection for evaporator in sys.B	Pd	
Protection	Defrosting	dF	
Protection	Protection for outdoor temp	PA	

15.2 Troubleshooting

① E0: Compressor phase sequence error or phase default

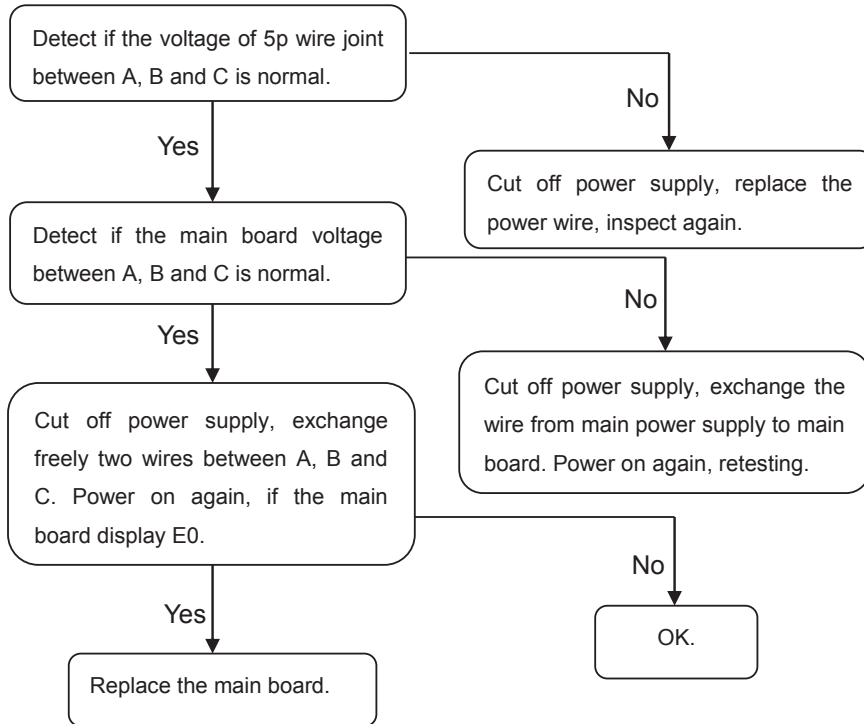

② E1: Outdoor coil temp. sensor T3 default.

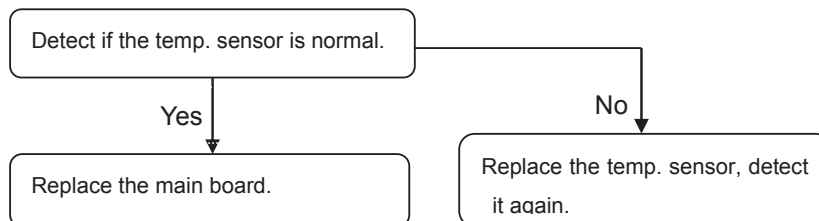

③ **E9: Indoor coil temp. sensor T2 default.**

(Indoor temp. and Pipe Temp. Sensor Resistance Value Table, see **Appendix 2**)

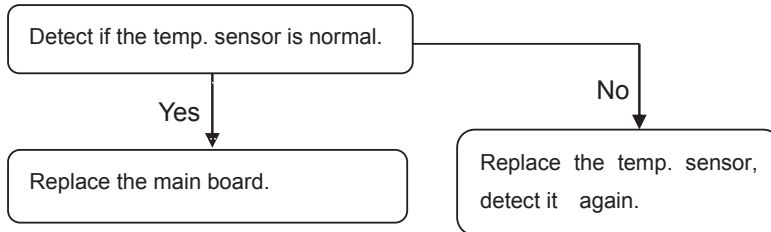

④ **When E2,E5,E6 or EA displays, please check the wired nameplate, if the terminals of T2_1、 T2_2、 T3_2、 T4 are connected as short circuit. If no, please connect all as short circuit, unless replace main board.**

⑤ **Eb: Wired controller output error.(Only for KJR-23B or KJR-25B).**

Avoid three conditions as following:

- 1) The wired controller output signal has Y, no G.
- 2) The wired controller output signal has W, no G.
- 3) The wired controller output signal has Y and W, no G.

⑥ **P0: Compressor over current protection.(The over current protection value is 16A)**

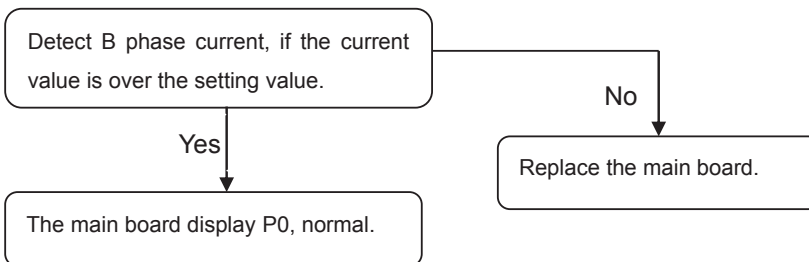

⑦ **P3: Comprehensive protection for outdoor fan**

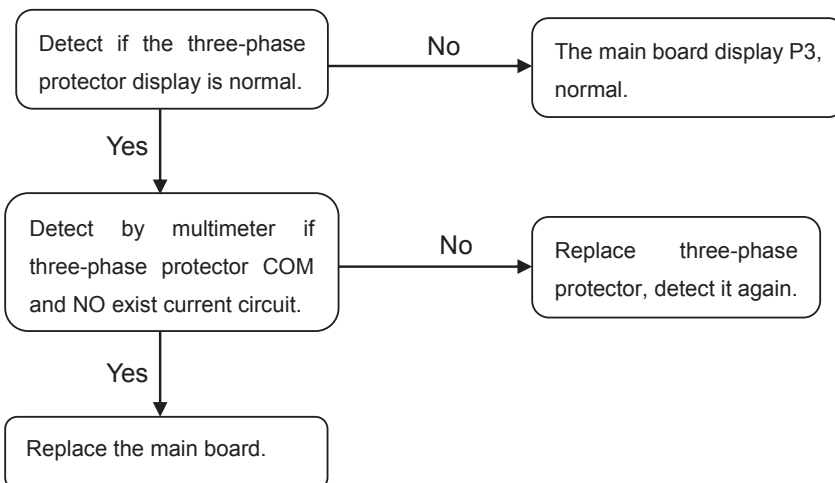

⑧ P4: Protection for Hi./Lo. Pressure or exhaust temp. (High pressure protection value: 4.4MPa, High pressure protection value: 0.14MPa; air discharge temp. protection value: 130℃ above)

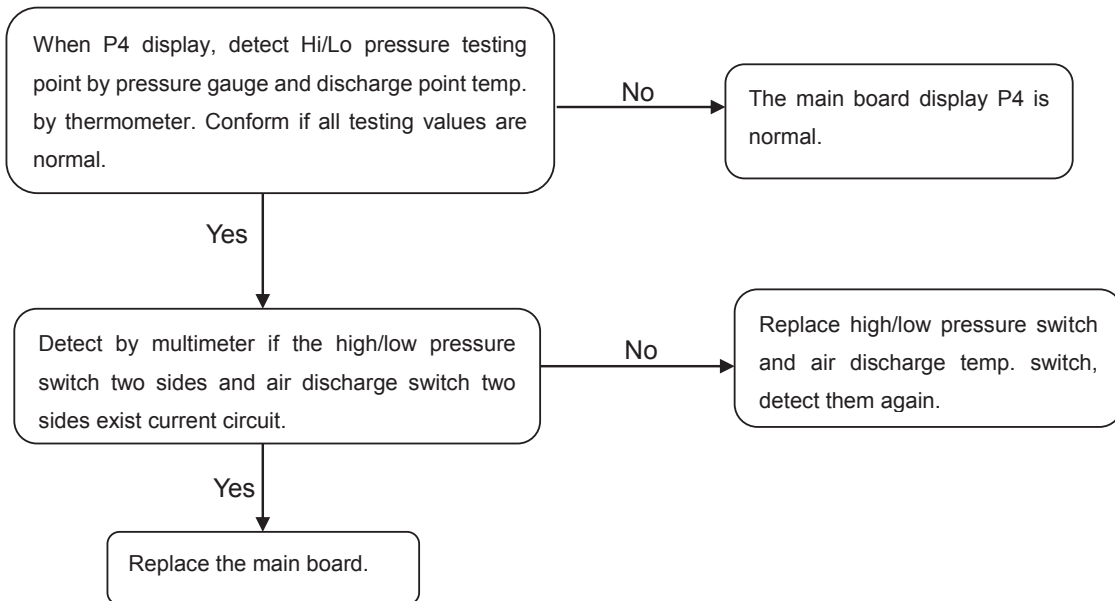

⑨ Indoor fan motor don't work.

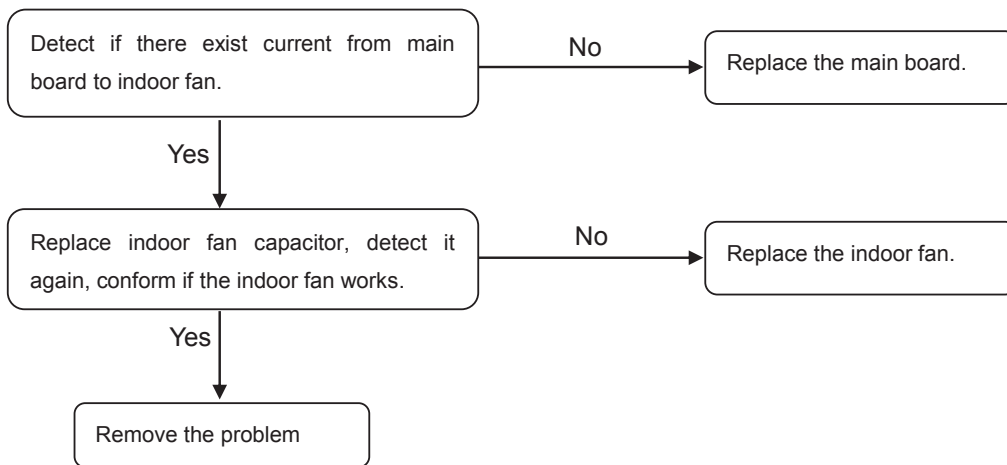

⑩ Outdoor fan motor don't work.

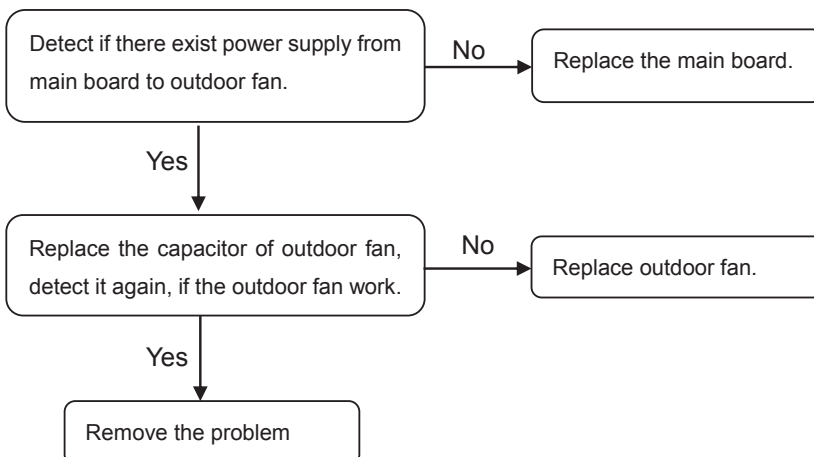

① **Indoor fan motor don't run.**

The first check if the power supplier is normal, if all wire connection terminal is loose, if the wired controller set and wire connection are correct, operating as flow process after confirm.

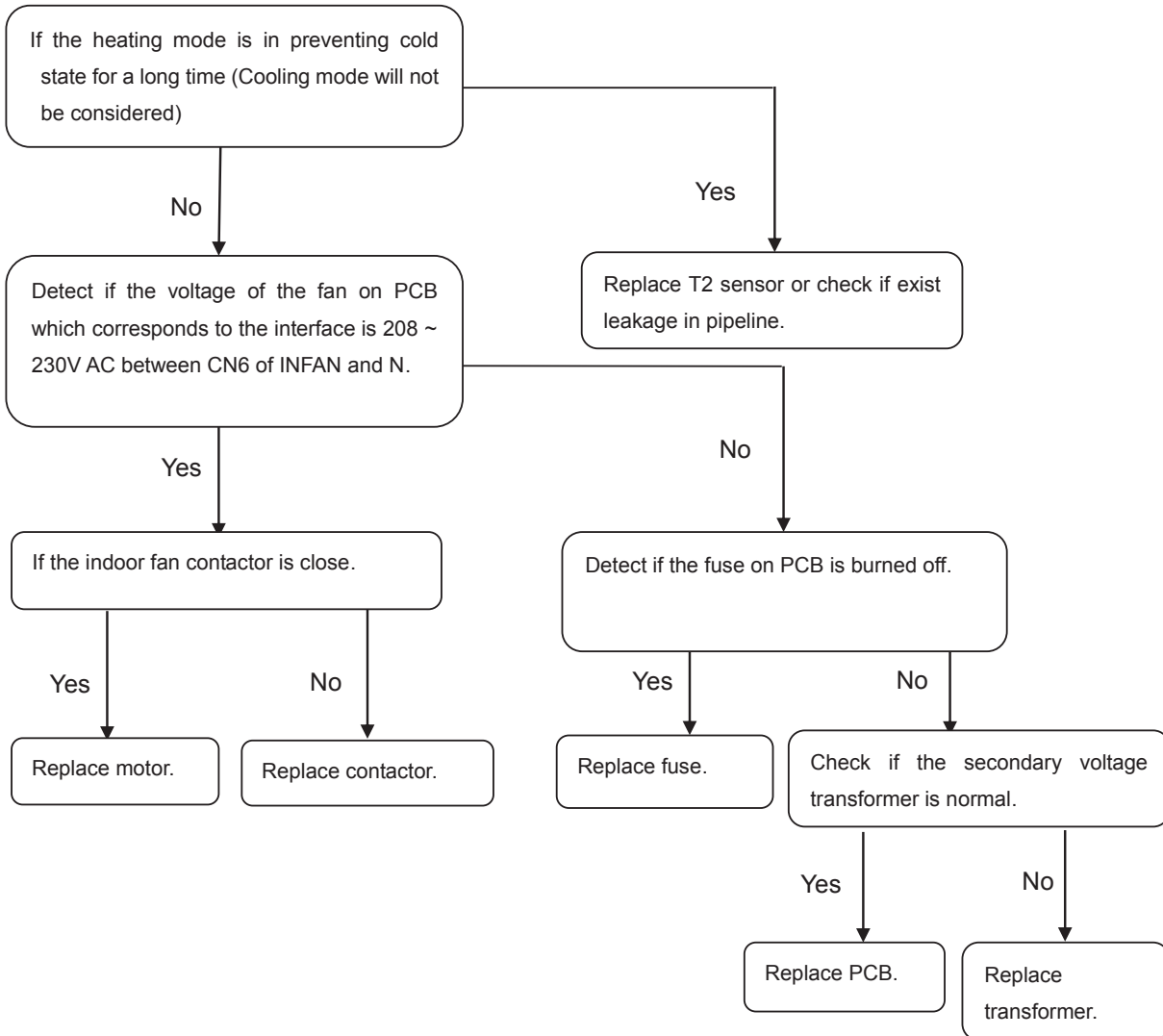

② Compressor don't run (All wires connection are correct and reliable, if power supplier is required range. If compressor don't run, you can analysis as flowing)

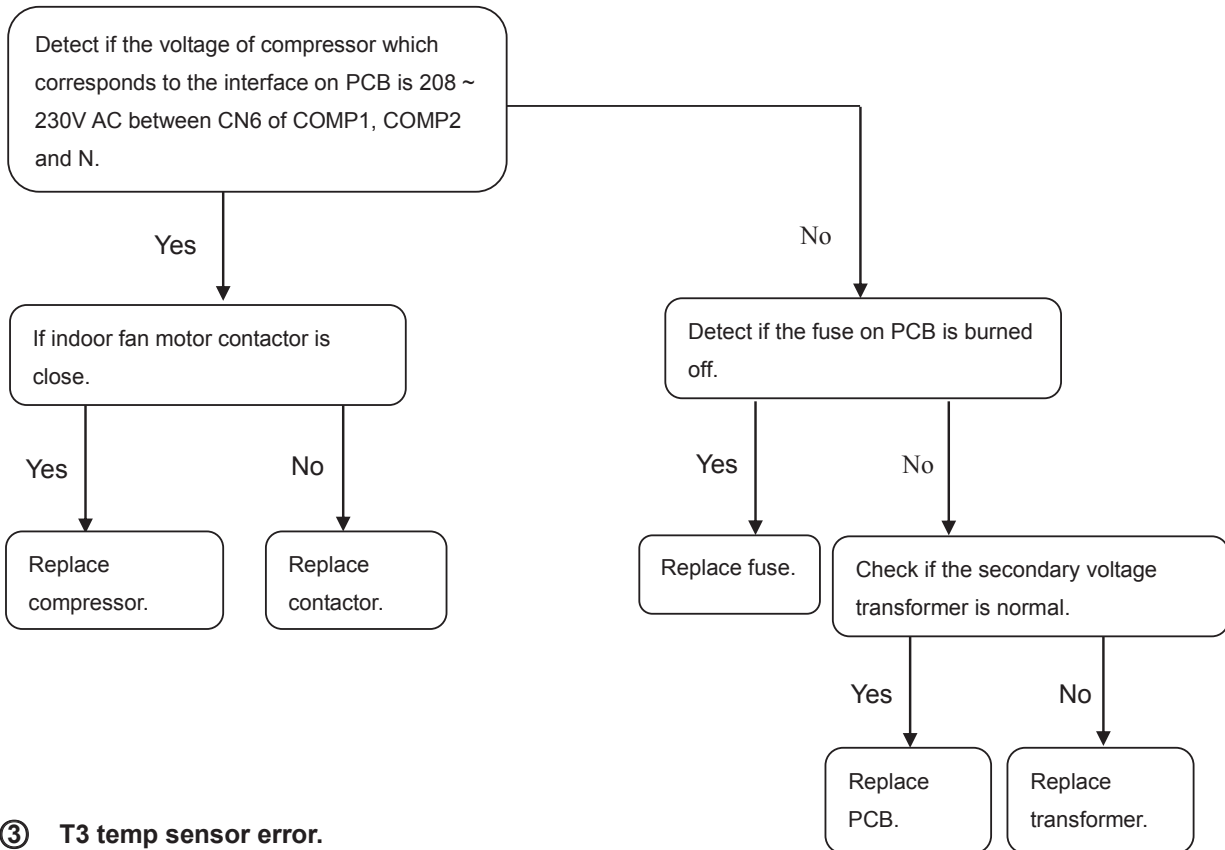

③ T3 temp sensor error.

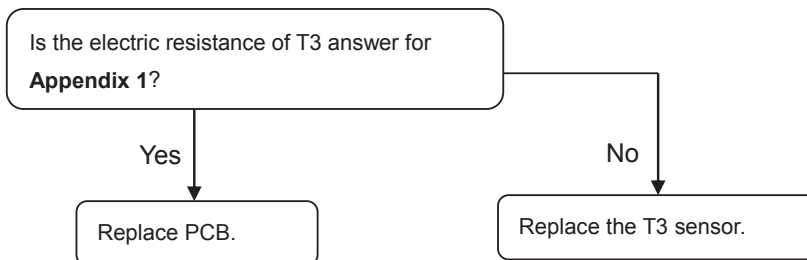

④ Check if the low pressure protection is normal.

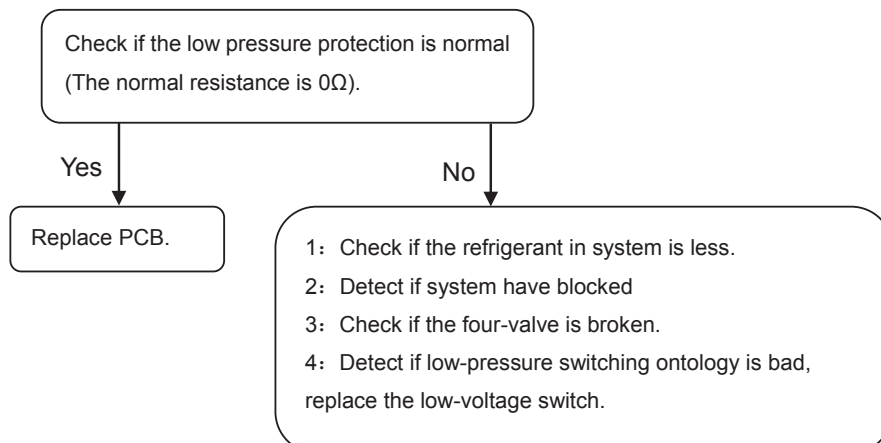

⑤ Outdoor fan motor don't run.

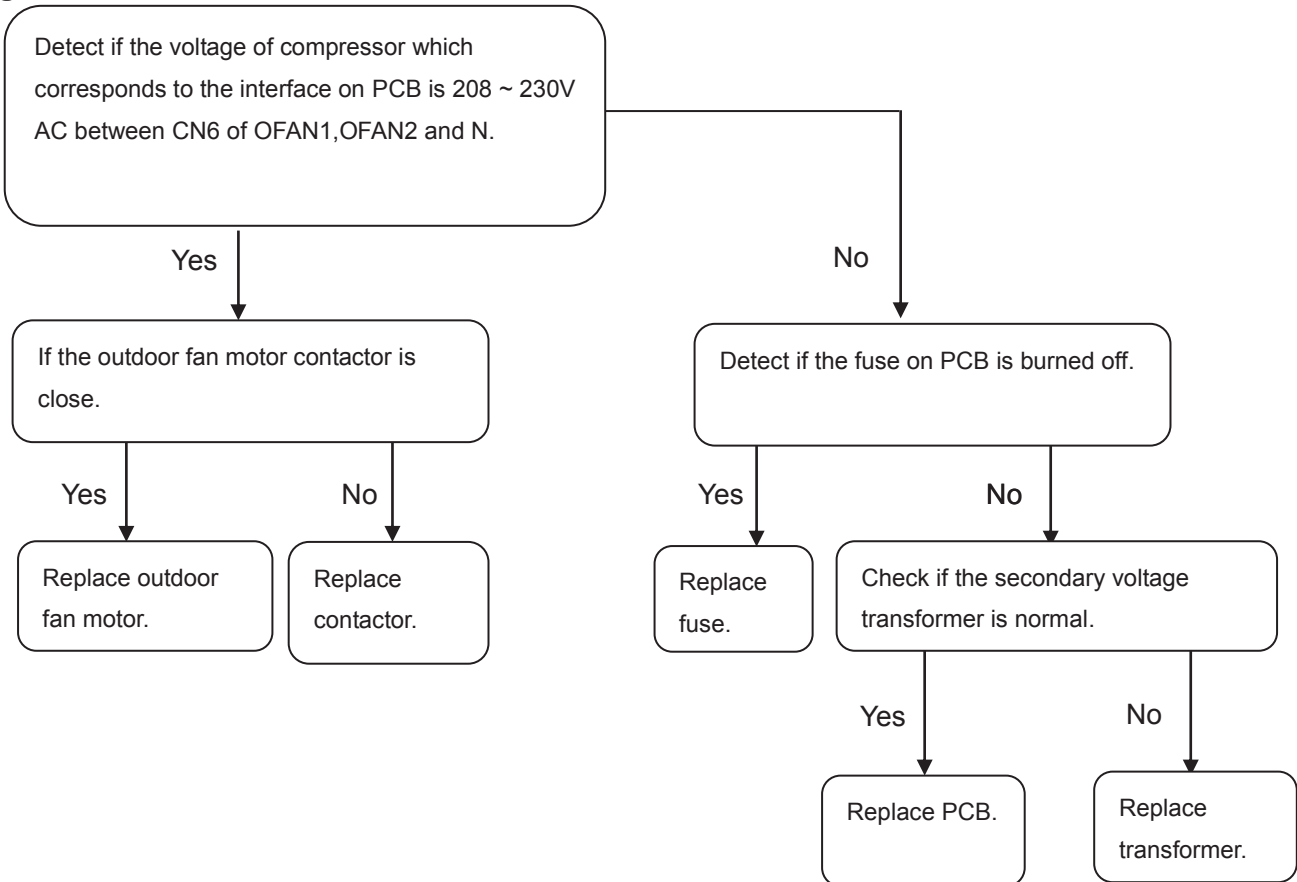



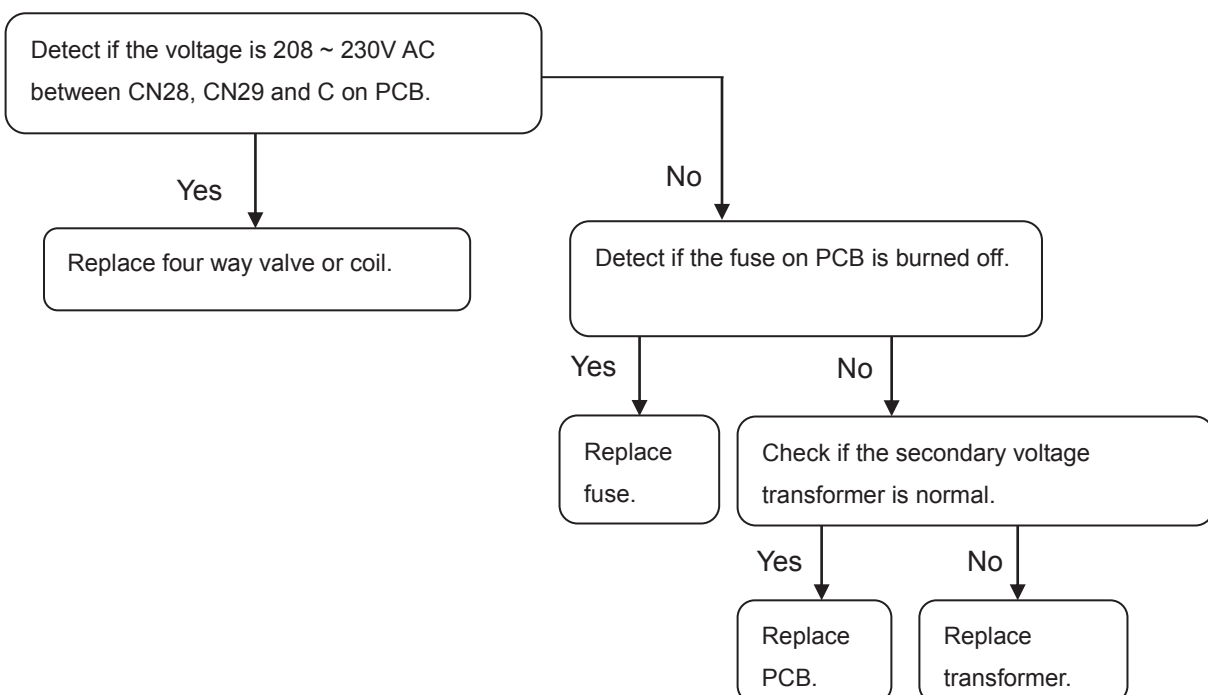

⑥ Four ways valve don't work.

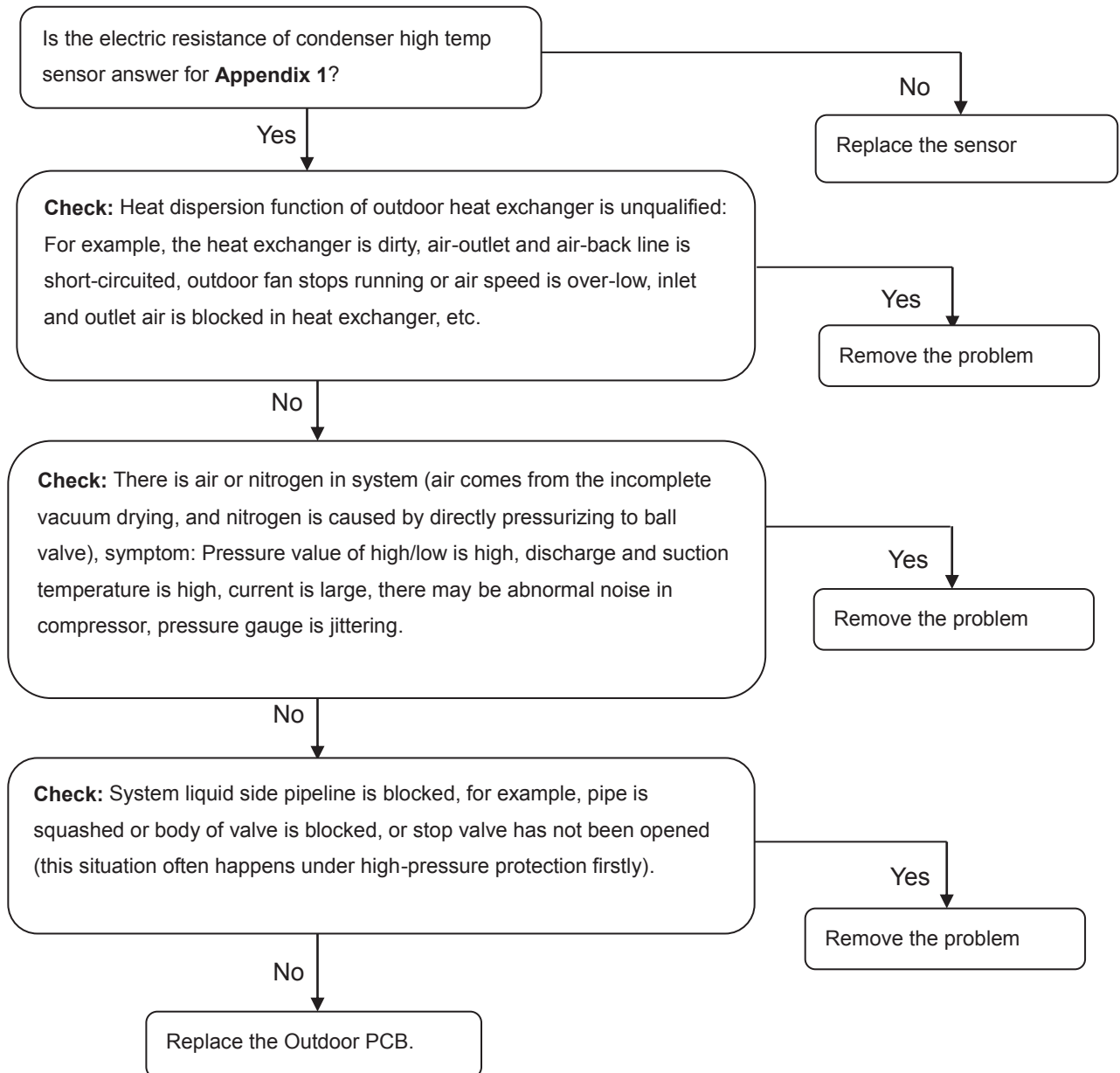

⑦ Condenser high temperature protection



16. Accessories

Name of accessories	Qty	Shape
Manual	1	
Drain outlet	1	
Snap ring	1	
Drain pipe	1	
KJR-12B Wired controller	1	

17. Maintenance and Upkeep

Regular maintenance and upkeep

Some regular maintenance and upkeep have been carry on by user, includes: change the one-time dust filter, clean casing, wash condenser and replace a new belt, as well as do some test for the equipment.

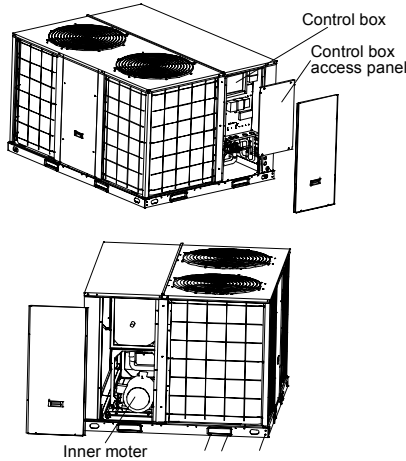

Tab.18-1

Model	A
6.2 Ton	328mm
7.5 Ton	328mm
8.5Ton	380mm
10 Ton	380mm
12.5Ton	560mm
15 Ton	560mm
17.5 Ton	580mm
20 Ton	580mm
25Ton	480mm
30Ton	480mm

Note: At least 1m flame resistant layer must be laid at the end of the air duct internal surface. Regulating belt of tension, Refer to the following Fig. loose 2 bolts, and move the electric motor to adjust belt tension.

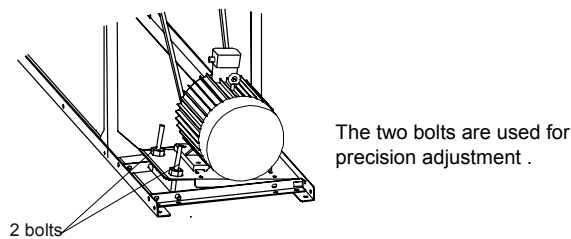

Belt tension is measured by belt tension indicator.

Calculate the deflection, $\text{deflection} = A/64$.

Measure the belt deflection force, the force should be between the values shown in Tab.18-2.

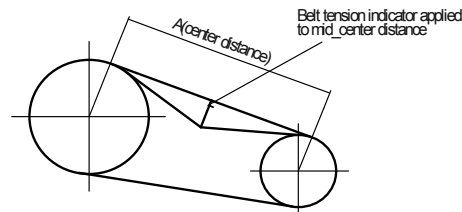

Tab.18-2

Belt section	For required to deflection		
	Small pulley diameter (mm)	Newton(N)	Kilogram-force(kgf)
SPA	80 to132	25 to 35	2.5 to 3.6

NOTE: The belt which is too tight or too loose may generate noise and be harmful to the unit.

Appendix :

1. Indoor Temperature and Pipe Temperature Sensor Resistance Value Table (8.5ton and above)

C°	K Ohm	C°	K Ohm	C°	K Ohm	C°	K Ohm
-20	115.266	20	12.6431	60	2.35774	100	0.62973
-19	108.146	21	12.0561	61	2.27249	101	0.61148
-18	101.517	22	11.5000	62	2.19073	102	0.59386
-17	96.3423	23	10.9731	63	2.11241	103	0.57683
-16	89.5865	24	10.4736	64	2.03732	104	0.56038
-15	84.2190	25	10.000	65	1.96532	105	0.54448
-14	79.3110	26	9.55074	66	1.89627	106	0.52912
-13	74.5360	27	9.12445	67	1.83003	107	0.51426
-12	70.1698	28	8.71983	68	1.76647	108	0.49989
-11	66.0898	29	8.33566	69	1.70547	109	0.48600
-10	62.2756	30	7.97078	70	1.64691	110	0.47256
-9	58.7079	31	7.62411	71	1.59068	111	0.45957
-8	56.3694	32	7.29464	72	1.53668	112	0.44699
-7	52.2438	33	6.98142	73	1.48481	113	0.43482
-6	49.3161	34	6.68355	74	1.43498	114	0.42304
-5	46.5725	35	6.40021	75	1.38703	115	0.41164
-4	44.0000	36	6.13059	76	1.34105	116	0.40060
-3	41.5878	37	5.87359	77	1.29078	117	0.38991
-2	39.8239	38	5.62961	78	1.25423	118	0.37956
-1	37.1988	39	5.39689	79	1.21330	119	0.36954
0	35.2024	40	5.17519	80	1.17393	120	0.35982
1	33.3269	41	4.96392	81	1.13604	121	0.35042
2	31.5635	42	4.76253	82	1.09958	122	0.3413
3	29.9058	43	4.57050	83	1.06448	123	0.33246
4	28.3459	44	4.38736	84	1.03069	124	0.32390
5	26.8778	45	4.21263	85	0.99815	125	0.31559
6	25.4954	46	4.04589	86	0.96681	126	0.30754
7	24.1932	47	3.88673	87	0.93662	127	0.29974
8	22.5662	48	3.73476	88	0.90753	128	0.29216
9	21.8094	49	3.58962	89	0.87950	129	0.28482
10	20.7184	50	3.45097	90	0.85248	130	0.27770
11	19.6891	51	3.31847	91	0.82643	131	0.27078
12	18.7177	52	3.19183	92	0.80132	132	0.26408
13	17.8005	53	3.07075	93	0.77709	133	0.25757
14	16.9341	54	2.95896	94	0.75373	134	0.25125
15	16.1156	55	2.84421	95	0.73119	135	0.24512
16	15.3418	56	2.73823	96	0.70944	136	0.23916
17	14.6181	57	2.63682	97	0.68844	137	0.23338
18	13.9180	58	2.53973	98	0.66818	138	0.22776
19	13.2631	59	2.44677	99	0.64862	139	0.22231



2. Indoor Temperature and Pipe Temperature Sensor Resistance Value Table (6. 2&7. 5ton)

Temp (C°)	Resistance (KΩ)			Resist.tol (%)		Temp.tol(°C)	
	Rmax	R (t) Normal	Rmin	MAX(+)	MIN(-)	MAX(+)	MIN(-)
-20	116.539	106.732	96.920	9.19	9.19	1.59	1.59
-19	110.231	100.552	91.451	9.63	9.05	1.57	1.57
-18	103.743	94.769	86.328	9.47	8.91	1.56	1.55
-17	97.673	89.353	81.525	9.31	8.76	1.54	1.54
-16	91.990	84.278	77.017	9.15	8.62	1.53	1.52
-15	86.669	79.521	72.788	8.99	8.47	1.51	1.50
-14	81.684	75.059	68.815	8.83	8.32	1.49	1.48
-13	77.013	70.873	65.083	8.66	8.17	1.47	1.47
-12	72.632	66.943	61.574	8.50	8.02	1.45	1.45
-11	68.523	63.252	58.274	8.33	7.87	1.44	1.43
-10	64.668	59.784	55.169	8.17	7.72	1.42	1.41
-9	61.048	56.524	52.246	8.00	7.57	1.40	1.39
-8	57.649	53.458	49.492	7.84	7.42	1.38	1.37
-7	54.456	50.575	46.899	7.67	7.27	1.35	1.35
-6	51.456	47.862	44.455	7.51	7.12	1.33	1.32
-5	48.636	45.308	42.150	7.35	6.97	1.31	1.30
-4	45.984	42.903	39.977	7.18	6.82	1.29	1.28
-3	43.490	40.638	37.927	7.02	6.67	1.27	1.26
-2	41.144	38.504	35.992	6.86	6.52	1.25	1.24
-1	38.935	36.492	34.165	6.70	6.38	1.23	1.21
0	36.857	34.596	32.440	6.53	6.23	1.21	1.19
1	34.898	32.807	30.810	6.38	6.09	1.18	1.17
2	33.055	31.120	29.271	6.22	5.94	1.16	1.15
3	31.317	29.528	27.815	6.06	5.80	1.14	1.12
4	29.681	28.026	26.440	5.90	5.66	1.12	1.10
5	28.138	26.608	25.140	5.75	5.52	1.10	1.08
6	26.682	25.268	23.909	5.60	5.38	1.07	1.06
7	25.310	24.003	22.745	5.45	5.24	1.05	1.03
8	24.016	22.808	21.644	5.30	5.10	1.03	1.01
9	22.794	21.678	20.601	5.15	4.97	1.01	0.99
10	21.641	20.610	19.614	5.00	4.83	0.99	0.97
11	20.553	19.601	18.680	4.86	4.70	0.96	0.94
12	19.525	18.646	17.794	4.71	4.57	0.94	0.92
13	18.554	17.743	16.955	4.57	4.44	0.92	0.90
14	17.636	16.888	16.160	4.43	4.31	0.90	0.88
15	16.769	16.079	15.406	4.29	4.19	0.88	0.85
16	15.949	15.313	14.691	4.15	4.06	0.86	0.83
17	15.174	14.588	14.014	4.02	3.94	0.84	0.81
18	14.442	13.902	13.372	3.89	3.81	0.81	0.79
19	13.748	13.251	12.762	3.75	3.69	0.79	0.76
20	13.093	12.635	12.183	3.62	3.57	0.77	0.74
21	12.471	12.050	11.634	3.50	3.46	0.75	0.72
22	11.883	11.496	11.112	3.37	3.34	0.73	0.70
23	11.327	10.971	10.617	3.25	3.23	0.71	0.68
24	10.800	10.473	10.147	3.12	3.11	0.69	0.66
25	10.300	10.000	9.700	3.00	3.00	0.67	0.63
26	9.848	9.551	9.255	3.11	3.10	0.69	0.66
27	9.418	9.125	8.834	3.21	3.19	0.72	0.69
28	9.010	8.721	8.434	3.31	3.29	0.75	0.71

Temp (C°)	Resistance (KΩ)			Resist.tol (%)		Temp.tol(°C)	
	Rmax	R(t) Normal	Rmin	MAX(+)	MIN(-)	MAX(+)	MIN(-)
29	8.621	8.337	8.055	3.41	3.38	0.77	0.74
30	8.252	7.972	7.695	3.51	3.47	0.80	0.77
31	7.900	7.625	7.353	3.61	3.57	0.83	0.79
32	7.566	7.296	7.029	3.70	3.66	0.85	0.82
33	7.247	6.982	6.721	3.80	3.74	0.88	0.84
34	6.944	6.684	6.428	3.89	3.83	0.91	0.87
35	6.656	6.401	6.150	3.98	3.92	0.93	0.90
36	6.381	6.131	5.886	4.08	4.00	0.96	0.93
37	6.119	5.874	5.634	4.17	4.09	0.98	0.95
38	5.870	5.630	5.395	4.26	4.17	1.01	0.98
39	5.631	5.397	5.167	4.34	4.26	1.03	1.01
40	5.404	5.175	4.951	4.43	4.34	1.06	1.03
41	5.188	4.964	4.745	4.52	4.42	1.09	1.06
42	4.982	4.763	4.549	4.60	4.50	1.12	1.09
43	4.785	4.571	4.362	4.69	4.58	1.14	1.12
44	4.596	4.387	4.183	4.77	4.66	1.17	1.14
45	4.417	4.213	4.014	4.85	4.74	1.19	1.17
46	4.246	4.046	3.851	4.93	4.81	1.22	1.20
47	4.082	3.887	3.697	5.02	4.89	1.25	1.23
48	3.925	3.735	3.550	5.10	4.97	1.28	1.25
49	3.776	3.590	3.409	5.18	5.04	1.30	1.28
50	3.632	3.451	3.274	5.25	5.12	1.33	1.30
51	3.495	3.318	3.146	5.33	5.19	1.35	1.33
52	3.363	3.191	3.023	5.41	5.26	1.41	1.36
53	3.237	3.069	2.905	5.49	5.34	1.43	1.38
54	3.116	2.952	2.793	5.56	5.41	1.46	1.41
55	3.001	2.841	2.685	5.64	5.48	1.48	1.44
56	2.890	2.734	2.582	5.71	5.55	1.51	1.46
57	2.784	2.632	2.484	5.79	5.62	1.54	1.49
58	2.682	2.534	2.390	5.86	5.69	1.56	1.52
59	2.585	2.440	2.299	5.93	5.76	1.59	1.54
60	2.491	2.350	2.213	6.01	5.83	1.62	1.57
61	2.401	2.264	2.130	6.08	5.90	1.64	1.60
62	2.315	2.181	2.051	6.15	5.96	1.67	1.62
63	2.233	2.102	1.975	6.22	6.03	1.70	1.65
64	2.154	2.026	1.903	6.29	6.10	1.72	1.68
65	2.077	1.953	1.833	6.36	6.16	1.75	1.70
66	2.004	1.883	1.766	6.42	6.23	1.77	1.73
67	1.934	1.816	1.702	6.49	6.29	1.80	1.76
68	1.867	1.752	1.641	6.56	6.35	1.83	1.78
69	1.802	1.690	1.582	6.62	6.41	1.85	1.81
70	1.740	1.631	1.525	6.69	6.48	1.88	1.84
71	1.680	1.574	1.471	6.75	6.54	1.91	1.86
72	1.622	1.519	1.419	6.82	6.60	1.93	1.89
73	1.567	1.466	1.369	6.88	6.66	1.96	1.92
74	1.514	1.416	1.321	6.94	6.71	1.98	1.94
75	1.463	1.367	1.275	7.00	6.77	2.01	1.97



Mechanical Specification

General

The units shall be dedicated horizontal airflow. The operation range shall be between 10 °F to -52 °F. All units shall be factory assembled, internally wired, fully charged with R410A, and 100 percent run tested to check cooling operation, fan and blower rotation and control sequence, before leaving the factory. Wiring internal to the unit shall be colored and numbered for simplified identification.

Casing

Unit casing shall be constructed of zinc coated, galvanized steel. Exterior surfaces shall be cleaned. Cabinet construction shall allow for all maintenance on one side of the units. Service panel shall have lifting handles. Pre-painted exterior cabinet panels pass 1000-hour Salt Spray Test for durability. Weather-resistant construction with capped seams and sloped top panels. G90 galvanized heavy gauge plate conforming to ASTM-A-653, Zinc content of galvanized plate is 275 g/m².

Filter

Two inch aluminum filter can be customized. Consist of two parts. Frame and aluminum filter.

Compressor

Adopt famous brand compressor, high IP class motor and reliable pressure switch. All models shall have crankcase heaters, low and high pressure control as standard.

Crankcase Heaters

These band heaters provide improved compressor reliability by warming the oil to prevent migration during off-cycles or low ambient conditions.

Refrigerant Circuits

Each refrigerant circuit shall have independent throttling devices, and refrigerant line filter driers factory installed as standard.

Evaporator and Condenser coils

Coil shall be leak tested at the factory to ensure the pressure integrity. Condensate drain pans are standard.

Outdoor Fans

The outdoor fan shall be direct-driven or belt driven, statically and dynamically balanced, draw-through in the vertical discharge position. The fan motor shall be permanently lubricated and shall have the built-in thermal overload protection.

Indoor Fans

Units shall have direct-driven and belt-driven, All motors shall be thermally protected.

New fan duct design

Optimized fan vane shape reduces pressure loss and improves heat exchange efficiency.

Controls

Unit shall be completely factory wired with necessary controls and contactor pressure lugs or terminal block for power wiring.

Outstanding reliability

Rooftop package units shall be factory assembled, internally wired, fully charged refrigerant and 100% run tested to check cooling and heating operation, fan and blower rotation, and control sequence before leaving the factory. Wiring internal to the unit shall be colored and numbered for simplified identification. The unit is provided with an integral weather resistant control panel.

Multiple self-protecting functions guarantee the safety of unit and running perfectly: high-pressure protection, low-pressure protection, over-heat protection, over-current protection and so on.

Anit corrosion

Anti-corrosion can be customized, G90 galvanized plate, alloy fan blade, stainless bolt can pass 2000 hours salt spray test. Copper tube & Aluminum fin can pass 600 hours salt spray test

Adjustable Pulley

Through changing the working pitch diameter of the pulley mounted on driver shaft, in turn the revolutions per minute of the driven shaft will increase or decrease to change air volume.

Easy drainage

External drainage port reserved, quickly and accurately connect the rubber drainage pipe.

External pressure gauge ports

The unit provide external pressure gauge ports, for convenient and fast checking without remove the panel.

Standard features/options/accessories

Description	Standard features	Options (factory installed)	Accessories (field installed)
Horizontal discharge	◆		
Compressor crankcase heaters	◆		
Evaporator fan-belt driven	◆		
Evaporator fan motor -ODP type(TEFC type optional)	◆		
Condenser fan -direct drive, propeller type(Except 5ton)	◆		
Condenser fan -direct drive, axial type(Only 5ton)	◆		
Condenser fan motor-totally enclosed air - over type	◆		
Filter, Nylon		◆	
Filter, aluminum(Thickness 25mm)		◆	
Compressor overload protection	◆		
Low &high pressure switch	◆		
Cooling & heating thermostat	◆		
Condenser fan guard	◆		
Condenser coil guard	◆		
Wired controller KJR-12B	◆		
Wired controller KJR-23B			◆
Wired controller KJR-25B			◆
Drainage pipe			◆
Drainage outlet			◆
Snap ring			◆



Notes:

A series of 25 horizontal dashed lines spanning the width of the page, intended for handwritten notes.



TRANE®

Literature Order Number RT-SVM003A-EN

Date May 2015

Supersedes NEW

Trane has a policy of continuous product and product data improvement and reserves the right to change design and specifications without notice. © 2014 Trane