

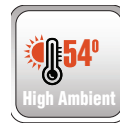

Product Catalogue



Wall Mounted On-Off F Series - High Ambient

R410a, 50Hz



Jan 2021

Contents

Model List	4
Outstanding Features	5
Function List	6
General Specifications	7
Outline Dimensional Diagram	9
Remote Controller	10
Nomenclature	16
Main Tools for Installation and Maintenance	18
Installation	19
Maintenance	31

Model List

IDU	MODEL	ODU	MODEL
1	4MCWFA12TB000AA	1	4TTKFA12TB000AA
2	4MCWFA18TB000AA	2	4TTKFA18TB000AA
3	4MCWFA24TB000AA	3	4TTKFA24TB000AA
4	4MCWFA30TB000AA	4	4TTKFA30TB000AA
5	4MCWFA36TB000AA	5	4TTKFA36TB000AA

Outstanding Features



30 sec 1 min



Quick Cooling/Heating

- Fast cooling around 30s/Powerful heating within 1 min. Provide comfort in time.
- Quick cooling and heating technology
- The rotating speed of compressor can reach 3900 r/min in 30 seconds.
- The start-up time was shortened via the quick driving of refrigerant operation.

Sleep Mode

- Intelligent design, to provide a quite and comfortable environment, more easy to enter the deep sleep state.

Self-Cleaning

- When this function is activated, firstly the indoor unit operates in cooling mode with low fan speed. During this period the condensed water will take dust on evaporator fins away. After that the unit turns to heating operation with low fan speed which dries the inside of indoor unit. Finally it turns to fan-only mode and blows away the rest wet air. The whole process keeps the internal side of indoor unit dry and prevents the breeding of bacteria.

4D Air Flow

- Helps to improve air distribution and flow. Makes you feel more comfortable.

Golden Fin

- Golden Fin is more resistant to oxidation and corrosion than ordinary blue fins of most condensers. It also prevents bacteria from breeding and is able to enhance heat efficiency.



general



Comfortable



Healthy



Intelligence

Function List

Function	Model				
	4MCWFA12TB000AA	4MCWFA18TB000AA	4MCWFA24TB000AA	4MCWFA30TB000AA	4MCWFA36TB000AA
	4TTKFA12TB000AA	4TTKFA18TB000AA	4TTKFA24TB000AA	4TTKFA30TB000AA	4TTKFA36TB000AA
ON/OFF-	S	S	S	S	S
AUTO	S	S	S	S	S
SPEED	S	S	S	S	S
TURBO	S	S	S	S	S
°C/°F change	S	S	S	S	S
Prevent cold wind	S	S	S	S	S
Dry	S	S	S	S	S
Sleep	S	S	S	S	S
I feel	S	S	S	S	S
Display	S	S	S	S	S
Silence	S	S	S	S	S
Self-diagnosis	S	S	S	S	S
IFAVOR	S	S	S	S	S
Anti-Restart	S	S	S	S	S
ECO	S	S	S	S	S
WIFI	S	S	S	S	S
Activated carbon paper filter	Optional	Optional	Optional	Optional	Optional

General Specifications

Model			IDU	4MCWFA12SB000AA	4MCWFA18SB000AA	4MCWFA24SB000AA	
			ODU	4TTKFA12SB000AA	4TTKFA18SB000AA	4TTKFA24SB000AA	
Nameplate Parameter	Rated Capacity	Cooling	W	3200	5200	6250	
	Rated Power	Cooling	W	1200	1950	2300	
	Rated Running Current	Cooling	A	4.7	8.3	8.6	
	Max. Input Power		W	1500	2500	2800	
	Max. Input Current		A	8.0	12	13.0	
	EER Cooling		W/W	2.25	2.36	2.17	
	Power supply source		V/Ph/Hz	220-240V-1-50Hz	220-240V-1-50Hz	220~240V-1-50Hz	
	Refrigerant			R410A	R410A	R410A	
	Refrigerant Charged		g	830	1100	1250	
	Max. Discharge Pressure		Mpa	4.15	4.3	4.15	
	Max. Suction Pressure		Mpa	1.15	1.15	1.15	
	Air Flow Volume		m ³ /h	580	950	1150	
	Noise level		dB (A)	≤40	43	≤47	
	Noise level		dB (A)	≤53	52	≤58	
Indoor unit weight (Net)		Kg	10	14	16		
Outdoor unit weight (Net)		Kg	28	38	42		
Indoor unit configuration	evaporator	Multi-bend		3	3	3	
		Rows	Row	2	2	2	
		tube pitch		20.5	20.5	20.5	
		row pich		25.4	25.4	25.4	
		Inlet and Outlet distributor		3in3out	4in4out	5in5out	
	Tube	Material		inner grooved tube	inner grooved tube	inner grooved tube	
		Quantity	piece	14	16	18	
	Fan system	Fan	Type		cross flow fan	cross flow fan	cross flow fan
			Material		AS+fiber glass	AS+fiber glass	AS+fiber glass
			Diameter		Φ92	106	Φ107.9
		Fan motor	Length	mm	597	715	839
			insulation grade		B	B	B
			Capacitor	uF	1.5	3.0	3
			Motor speed	rpm	1130/1015/900	1230/1080	1230/1080/965
	Rated Current	A	0.177462289	0.44	0.6		
	Rated Input	W	40	102	60		
	Rated Output	W	18	50	50		
	Dimension	Packing Type (6 face/4 face)		6 face	6 face	6 face	
		Net Dimension	mm	800×300×198	1100×330×235	1100×330×235	
		Packing Dimension	mm	870×370×282	1180×400×317	1180×400×317	
Condensate Drainage Pipe (O.D)			16.9	16.9	16.9		
Condensate Drainage Pipe (L)		mm	2000	2000	2000		
Compressor Parameter	type		Rotary	Rotary	Rotary		
	Brand		GMCC	HIGHLY	HIGHLY		
	Capacity	W	3610/3625	4695	5580		
	Input	W	845/895	1565	1860		
	Rated current(RLA)	A	3.85/3.75	6.95	8.7		
	Locked rotor Amp(LRA)	A	25 ±10%	38	48		
	Capacitor	uF	35	45	55		
Fan system	Fan motor	Capacitor	uF	2	2.5	4	
		Motor speed	rpm	770	930	830	
		Rated Current	A	0.333	0.322	0.8	
		Rated Input	W	74	72	80	
	Rated Output	W	30	31	69		
Air circulation	m ³ /h		1800	2350	2800		
Condenser	Rows	Row	1	2	2		
	tube pitch		25.4	20.5	20.5		
	row pich		22	19.05	25.4		
	Inlet and Outlet distributor		1in1out	2in2out	2in1out		
	Bended or Flat		Bended	Bended	Bended		
	Tube	Material		inner grooved tube	inner grooved tube	inner grooved tube	
		Length	mm	701	877	791	
		Diameter	mm	9.52	7	7	
		Thickness		0.27	0.24	0.24	
		Quantity	pieces	10	22	26	
Net Dimension	mm		730×545×285	800×545×315	825×655×310		
Packing Dimension	mm		847×615×362	920×615×392	945×725×435		
Container Loading 40HC		set	242	195	148		

General Specifications

Model		IDU	4MCWFA30SB000AA	4MCWFA36SB000AA		
		ODU	4TTKFA30SB000AA	4TTKFA36SB000AA		
Nameplate Parameter	Rated Capacity	Cooling	W	7500	7600	
	Rated Power	Cooling	W	2400	3600	
	Rated Running Current	Cooling	A	11	16.5	
	Max. Input Power		W	3300	4400	
	Max. Input Current		A	16.5	22.0	
	EER Cooling		W/W	3.12	2.11	
	Power supply source		V/Ph/Hz	220-240V-1-50Hz	220-240V-1-50Hz	
	Refrigerant			R410A	R410A	
	Refrigerant Charged		g	1250	2000	
	Max. Discharge Pressure		Mpa	4.3	4.3	
	Max. Suction Pressure		Mpa	1.15	1.15	
	Air Flow Volume		m ³ /h	1250	1600	
	Noise level		dB (A)	48	48	
	Noise level		dB (A)	56	59	
	Indoor unit weight (Net)		Kg	16	16	
	Outdoor unit weight (Net)		Kg	54.5	62	
Indoor unit configuration	evaporator	Multi-bend		3	3	
		Rows	Row	2	2	
		tube pitch		20.5	20.5	
		row pich		25.4	25.4	
		Inlet and Outlet distributor		5in5out	6in6out	
	Tube	Material		inner grooved tube	inner grooved tube	
		Quantity	piece	18	20	
	Fan system	Fan	Type		cross flow fan	cross flow fan
			Material		AS+fiber glass	AS+fiber glass
			Diameter		Φ107.9	Φ107.9
		Fan motor	Length	mm	839	978
			insulation grade		E	E
			Capacitor	uF	NO	NO
			Motor speed	rpm	1330/1180/1040/900	1330/1180/1040/900
	Dimension	Rated Current	A	0.24	0.24	
		Rated Input	W	72	72	
		Rated Output	W	45	45	
		Air circulation (H/M/L)	m ³ /h	1300	1300	
		Packing Type (6 face/4 face)		6 face	6 face	
	Condensate Drainage Pipe (O.D)	Net Dimension	mm	1100×330×235	1250×358×253	
Packing Dimension		mm	1180×400×317	1340×445×355		
Condensate Drainage Pipe (O.D)			16.9	16.9		
Condensate Drainage Pipe (L)		mm	2000	2000		
Compressor Parameter	Compressor	type		Rotary	Rotary	
		Brand		HIGHLY	HIGHLY	
		Capacity	W	6870	8550	
		Input	W	2290	2950	
		Rated current(RLA)	A	11.4	14.1	
		Locked rotor Amp(LRA)	A	61	67	
Fan system	Fan motor	Capacitor	uF	50	55	
		Capacitor	uF	4	6	
		Motor speed	rpm	890	860	
		Rated Current	A	0.7	0.8	
		Rated Input	W	162	120	
		Rated Output	W	86	70	
Condenser	Air circulation		m ³ /h	2800	3000	
		Rows	Row	2	2	
	tube pitch			22	22	
		row pich		19.05	19.05	
	Inlet and Outlet distributor			2in1out	4in4out	
		Bended or Flat		Bended	Bended	
	Tube	Tube	Material		inner grooved tube	inner grooved tube
			Length	mm	705	744+774
			Diameter	mm	7	7.94
			Thickness		0.24	0.24
Quantity			pieces	30	28	
Net Dimension		mm	900×700×350	970×805×395		
	Packing Dimension	mm	1015×762×425	1105×885×495		
Container Loading 40HC			set	138	101	

Capacity Table

model	Indoor Air DBT		Outdoor Air Dry Bulb Temperature 115F(46°C)					
			Indoor Air Wet Bulb Temperature F(°C)					
			67F (19°C)			63F (17°C)		
	°C	F	TC	SHC	LHC	TC	SHC	LHC
4MCWFA12TB000AA 4TTKFA12TB000AA	27°C 24°C	80F 76F	3426.1 3446.2	2561.0 2880.6	865.0 565.6	3255.6 3265.8	2644.5 2986.5	611.0 279.3
4MCWFA18TB000AA 4TTKFA18TB000AA	27°C 24°C	80F 76F	5351.1 5369.7	3807.1 4214.6	1543.8 1155.1	5049.4 5065.8	3930.1 4286.4	1119.3 779.4
4MCWFA24TB000AA 4TTKFA24TB000AA	27°C 24°C	80F 76F	7093.3 7114.6	5096.9 5566.3	1996.1 1548.3	6701.4 6720.2	5248.0 5695.9	1453.4 1024.3
4MCWFA30TB000AA 4TTKFA30TB000AA	27°C 24°C	80F 76F	7460.9 7477.4	5366.9 5825.1	2094.0 1652.3	7066.7 7087.8	5546.5 5995.5	1520.2 1092.3
4MCWFA36TB000AA 4TTKFA36TB000AA	27°C 24°C	80F 76F	7642.4 7660.1	5533.5 6022.4	2108.9 1637.7	7197.4 7216.2	5662.6 6116.4	1534.8 1099.8

MODEL	Liquid side (inches)	Gas side (inches)
12K	1/4"	3/8"
18K	1/4"	1/2"
24K	1/4"	5/8"
30K	1/4"	5/8"
36K	1/4"	5/8"

Outline Dimension Diagram

Indoor Unit

Cooling capacity	Boundary Dimension W×H×D (mm)	Package Size W×H×D (mm)
12K	800×300×198	870×370×282
18K	1100×330×235	1180×400×317
24K	1100×330×235	1180×400×317
30K	1100×330×235	1180×400×317
36K	1250×358×253	1340×445×355

Indoor Unit

Platform	Boundary Dimension W1(W2)×H×D(mm)	Package Size W×H×D(mm)
1.3P	730×545×285	847×615×362
1.8P	800×545×315	920×615×392
New 2P	920×615×392	945×725×435
2.3P	900×700×350	900×700×350
New 3P	970×805×395	1105×885×495

Note:

- The main body size of the front shape after normal installation: width ×height ×depth (mm). An example of the dimension measurement is shown in the figure.
 - Width direction:
 - Width 1: Not include the size of the stop valve.
 - Width 2: Include the size of the stop valve.
 - Height direction: including the height of the mounting foot;
 - Depth direction: not include the size of mounting foot but include the size of the large-area parts such as panel grille
- Base footing center size A ×B.

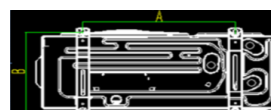
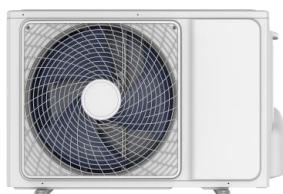
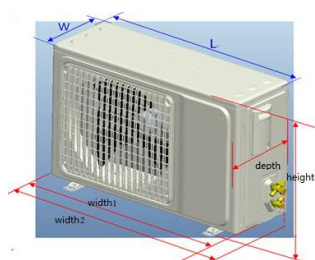

Remote Controller

1) Remote Controller Introduction

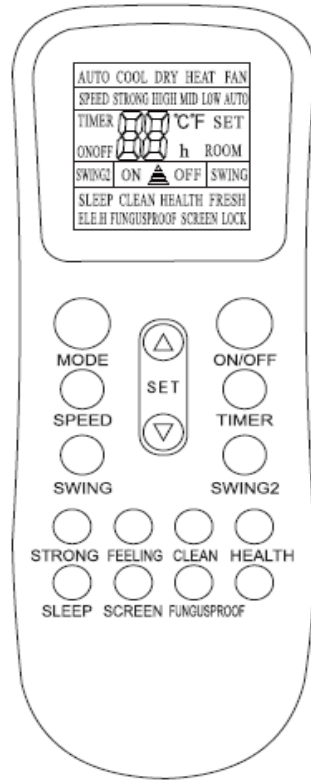

- Read this "instructions" carefully so that you can use the air-conditioner safely and correctly.
- Take good care of the "instructions" so that it can be referred to at any time.

Remote Controller

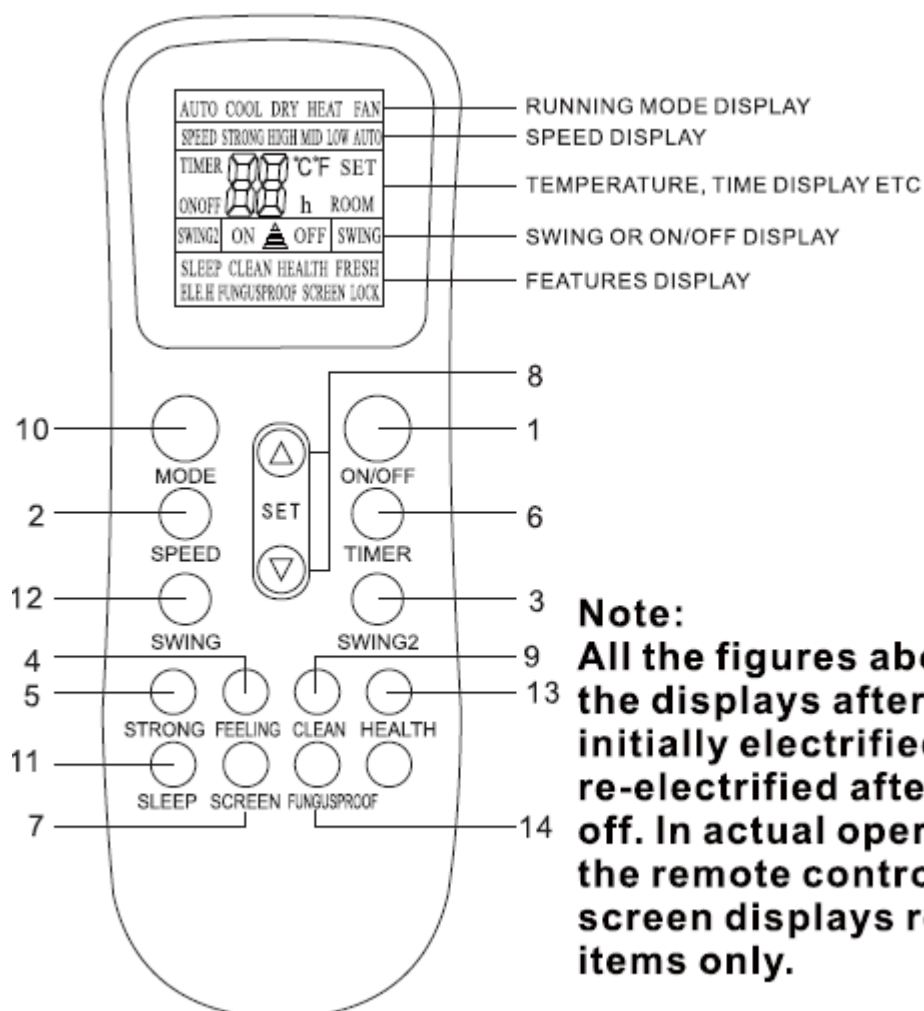

Note:
All the figures above are the displays after being initially electrified or re-electrified after power off. In actual operations, the remote controller screen displays related items only.

The cooling only units don't have the function of heating or electric heating. When the remote controller turns to such function buttons, the units will not result such effect.

* Please don't turn the remote controller to such buttons.

Note : The picture is general remote controller, contains almost all of the function buttons, They may be slightly different from material object(depend on model).

1. "ON/OFF" button

You can start or stop the air-conditioner by pressing this button.

2."SPEED" button

You can select motor speed as the following:

➤ Low → Mid → High → Auto

Remote Controller

3. "SWING2" button

Press this button, the vertical wind direction vanes can rotate automatically when you have the desired horizontal wind direction, press it again, the vertical wind direction vanes will be stopped at the situation of your choice.

4. "FEELING" button

When it displays "FEELING" button :

Press this button can be used to set the feeling function. The LCD shows the actual room temperature when the function set and it shows the setting temperature when the function cancelled. This function is invalid when the appliance at the fan mode.

5. "STRONG" button

Only under the state of cooling or heating mode, press this button, the motor speed is adjusted to strong auto-matically and the LCD displays "high motor", the "strong" function is started to reach the highest cooling or heating.

6. "TIMER" button

Setting the "ON" timer time:

- When remote controller is at off state, press "TIMER" button, the LCD displays "TIMER ON" and the timer time, the range of setting time is 0.5h to 24h.
- You can press the "△" or "▽" button to adjust the timer time, each touch will be set time to increase or reduce 0.5h before 10 hours ago, after ten hours will be set time to increase or reduce 1h per pressing, to enables your required timer.
- Press "TIMER" button again, to set the timer on function.
- You can set another function to insure the suitable state after air conditioner turn on (including mode, temperature, swing, motor speed and etc). The LCD will displays all your setting and keep it, when the timer reach to the set time, the air conditioner will be working according to your set automatically.

Setting the "OFF" timer time:

- When remote controller is at on state, press "TIMER" button, the LCD displays "TIMER OFF" and the timer time, the range of setting time is 0.5h to 24h.
- You can press the "△" or "▽" button to adjust the timer time, each touch will be set time to increase or reduce 0.5h before 10 hours ago, after ten hours will be set time to increase or reduce 1h per pressing, to enables your required timer.
- Press "TIMER" button again, to set the timer on function.

7. "TIMER" button

You can let the LCD display working or not by pressing this button.

8. "△" or "▽" button

Press the "+" or "-" button, you can set the temperature range from 16°C to 32°C, Display will change when you touch the button.

9. "CLEAN" button

- When remote controller is at the off state, press "clean" button, the wind guiding bars turn to initial positions for cooling, the A/C runs "clean" function with max duration 35mins. The purpose of this function is to clean dust on evaporator and dry the inside water of evaporator and to prevent the evaporator going moldy due to water deposition and boasting strange smell.
- After setting "clean" function, press "clean" button again to cancel "clean" function or press ON/OFF" button to cancel "clean" function and start A/C.
- The clean function will be stop working after 35 minutes running working without any operation.

Note: "clean" function can be set in parallel with " time start " function; in this case, "time start " function will be executed after "clean" function.

Remote Controller

10. "MODE" button

Which enables you to select different operation mode, after each pressing, the operation mode will be changed. It shows in the following display.

AUTO → COOL → DRY → HEAT → FAN → AUTO

Remark : cold wind type has no heating function.

11. "SLEEP" button

1. Press the SLEEP button, the sleeping indicator light of indoor unit flashes on.
2. After the setting of sleeping mode, the cooling operation enables the set temperature to increase 1°C after 1 hour and another 1°C automatically after 1 hour.
3. After the setting of sleeping mode, the heating operation enables the set temperature to drop 1°C after 1 hour and another 2°C automatically after 1 hour.
4. The air-conditioner runs in sleeping mode for 7 hours and stops automatically. **Remark : press the MODE or ON/OFF button the remote, the remote controller clears sleeping mode away.**

12. "SWING" button

Press this button, the horizontal wind direction vanes can swing automatically, when you have the desired vertical wind direction, press it again, the horizontal wind direction vanes will be stopped at the situation of your choice.

13. "SLEEP" button

Press this button you can turn on or off the health function.

14. "FUNGUSPROOF" button

This A/C has special dry and anti-mold function which has "yes" or "no" two selections. This function is controlled by the remote controller under cooling, dry and auto (cooling and dry) modes, the horizontal wind guiding bars are at the initial position for cooling. The A/C runs under heating mode (the cooling only A/C only runs under fan mode), the Indoor Unit motor runs for three minutes with weak wind before stop. The purpose of this function is to dry the inside of the evaporator and to prevent the evaporator from going mouldy due to water deposition and thus dispersing strange smell.

Note :

1. This function has not been set in the factory. You may freely set and cancel this function. The setting method is: under "off" status of the A/C and the remote Controller, point the remote controller toward the A/C and continuously press "FUNGUSPROOF" push button for one time, the buzzer keep beeping five times again after five times beep, indicating that this function is ready. In case this function has been set, unless the whole A/C is powered off or the function is manually cancelled, the A/C then has this function as default;
2. To cancel the function : ① Power off the whole A/C; ② Under "off" status of the A/C and the remote controller, point the remote controller toward the A/C and continuously press "FUNGUSPROOF" push button for one time, the buzzer keep beeping three times again after five times beep, including that this function has been cancelled;
3. When this function is on, it is suggested not to restart the A/C before it is completely stop;
4. This function will not run in case of time stop or sleep stop.

Remote Controller

2) Introduction for mode settings

★Automatic operation mode

1. Press the ON/OFF button the air-conditioner starts to operate.
2. Press the MODE button select the automatic operation mode.
3. Press the SPEED button, you can select motor speed. You can select motor speed from LOW, MID, HIGH, AUTO.
4. Press the button again, the air-conditioner stops.

★Cooling/Heating operation mode (cold wind type has no heating function)

1. Press the ON/OFF button, the air-conditioner starts to operate.
2. Press the MODE button, select the Cooling or Heating operation mode.
3. Press the “ Δ ” or “ ∇ ” button, set the temperature, temperature can be set at 1°C difference range from 16-32°C.
4. Press the SPEED button you can select motor speed. You can select motor speed from LOW, MID, HIGH, AUTO.
5. Press the button again, the air-conditioner stops.

★Fan operation mode

1. Press the ON/OFF button, the air-conditioner starts to operate.
2. Press the MODE button, select the Cooling or Heating operation mode.
3. Press the SPEED button, you can select motor speed. You can select motor speed from LOW, MID, HIGH.

Remark : In the circulation operation mode, to set the temperature is non effective.

★Drying operation mode

1. Press the ON/OFF button, the air-conditioner starts to operate.
2. Press the MODE button, select the Dry operation mode.
3. Press the “ Δ ” or “ ∇ ” button, set the temperature, temperature can be set at 1°C difference range from 16-32°C.
4. Press the SPEED button you can select motor speed. You can select motor speed from LOW, MID, HIGH, AUTO.
5. Press the button again, the air-conditioner stops.

Note:

This manual introduces function for all of the remote control, maybe you press one button without any reaction, well, the air-conditioner you bought hasn't this function.

★Fix batteries



1. Slide open the cover according the direction indicated by arrowhead.
2. Put into two brand new batteries (7#), position the batteries to right electric poles (+&-).
3. Put back the cover.

Remote Controller

Attention

1. Aim the remote controller towards the receiver on the air-conditioner.
2. The remote controller should be within 8 meters away from the receiver.
3. No obstacles between the remote controller and receiver.
4. Do not drop or throw the remote controller.
5. Do not put the remote controller under the forceful sunrays or heating facilities and other heating sources.
6. Use two 7# batteries, do not use the electric batteries.
7. Take the batteries out of remote controller before stop its using for long.
8. When the noise of transmitting signal can't be heard indoor unit or the transmission symbol on the display screen doesn't flare, batteries need to be replaced.
9. If reset phenomenon occurs on pressing the button of the remote controller, the electric quantity is deficient and new batteries need to be substituted.
10. The waste battery should be disposed properly.

Nomenclature

Indoor Unit

4 M C W F A 1 8 T B 0 0 0 A A
1 2 3 4 5 6 7 8 9 10 11 12 13 14 15

Digit #1 = Refrigerant

4 = R410A

Digit #2 = Brand

M = Trane Indoor unit

Digit #3 = Function Type

C = Cooling Only Fixed Speed, Single
W = Heat Pump Fixed Speed, Single

Digit #4 = Indoor Unit type

D = Concealed Duct Type
W = High wall unit
C = Cassette Type

Digit #5, 6 = Product family

**Digit #7, 8 = Nominal Capacity
(BTU/h x 1,000)**

12 = 12,000 BTU/h
18 = 18,000 BTU/h
24 = 24,000 BTU/h
30 = 30,000 BTU/h
36 = 36,000 BTU/h

Digit #9 = Ambient Temperature /

T = T3 High Ambient
S = T1 Standard Ambient

**Digit #10 = Electric Power Supply
Characteristics**

B = 220-240/1/50 (V/Ph/Hz)
D = 380-415/1/50 (V/Ph/Hz)

Digit #11 = Factory Supplied

0 = Standard efficiency
S = Special

Digit #12 = Controls

0 = Default (Wireless Control for high wall & Wired Control for ducted)

Digit #13 = Reserved for Future Use

**Digit #14 = Service Digit /
Reserved for Future Use**

A = First Sequence
A = Not currently used

**Digit #15 = Minor Design
Sequence**

A = First Design Sequence
B = Second Design Sequence
C = Third Design Sequence

Nomenclature

Outdoor Unit

4 M C W F A 1 8 T B 0 0 0 A A
1 2 3 4 5 6 7 8 9 10 11 12 13 14 15

Digit #1 = Refrigerant

4 = R410A

Digit #2 = Brand

M = Trane Indoor unit

Digit #3 = Function Type

C = Cooling Only Fixed Speed, Single

W = Heat Pump Fixed Speed, Single

Digit #4 = Indoor Unit type

D = Concealed Duct Type

W = High wall unit

C = Cassette Type

Digit #5, 6 = Product family

Digit #7, 8 = Nominal Capacity (BTU/h x 1,000)

12 = 12,000 BTU/h

18 = 18,000 BTU/h

24 = 24,000 BTU/h

30 = 30,000 BTU/h

36 = 36,000 BTU/h

Digit #9 = Ambient Temperature /

T = T3 High Ambient

S = T1 Standard Ambient

Digit #10 = Electric Power Supply Characteristics

B = 220-240/1/50 (V/Ph/Hz)

D = 380-415/1/50 (V/Ph/Hz)

Digit #11 = Factory Supplied

0 = Standard efficiency

S = Special

Digit #12 = Controls

0 = Default (Wireless Control for high wall & Wired Control for ducted)

Digit #13 = Reserved for Future Use

Digit #14 = Service Digit / Reserved for Future Use

A = First Sequence

A = Not currently used

Digit #15 = Minor Design Sequence

A = First Design Sequence

B = Second Design Sequence

C = Third Design Sequence

Main Tools for Installation and Maintenance

Main Tools for Installation and Maintenance

Screwdriver , Wire stripper	Tapeline , Spirit level	Allen wrench , Wrench
		
Hammer , Electric hammer	Water drill punch , Drill	Forming Drill
		
Cutting Knife	Belling Expander	Thermometer , Electro Probe
		
Pressure Gage	Pliers , Clip-on Ammeter	Vacuum Pump
		
Soldering Set	Refrigerant	Safety Belt , Safety Rope
		

Installation

Notes for Installations

Important Notices

- Before installation, please contact with local authorized maintenance center, if unit is not installed by the authorized maintenance center, the malfunction may not solved, due to discommodious contact.
- The air conditioner must be installed by professionals according to the national wiring rules and this manual.
- To move and install air conditioner to another place, please contact our local special service center.

Requirements For Installation

- Avoid places of inflammable or explosive gas leakage or where there are strongly aggressive gases.
- Avoid places subject to strong artificial electric/magnetic fields.
- Avoid places subject to noise and resonance.
- Avoid severe natural conditions (e.g. heavy lampblack, strong sandy wind, direct sunshine or high temperature heat sources).
- Avoid places within the reach of children.
- Shorten the connection between the indoor and outdoor units.
- Select where it is easy to perform service and repair and where the ventilation good.
- The outdoor unit shall not be installed in any way that could occupy an aisle, stairway, exit, fire escape, catwalk or any other public area.
- The outdoor unit shall be installed as far as possible from the doors and windows of the neighbors as well as the green plants.

Requirements for operations at raised height

- When carrying out installation at 2m or higher above the base level, safety belts must be worn and ropes of sufficient strength be securely fasten to the outdoor unit, to prevent falling that could cause personal injury or death as well as property loss.

Requirements of the mounting structure

- The mounting rack must meet the relevant national or industrial standards in terms of strength with welding and connection areas rustproofed.
- The mounting rack and its load carry surface shall be able to withstand 4 times or above the weight of the unit, or 200kg, whichever is heavier.
- The mounting rack of the outdoor unit shall be fastened with expansion bolt.
- Ensure the secure installation regardless of what type of wall on which it is installed, to prevent potential dropping that could hurt people.

Electrical Safety Requirements

- Be sure to use the rated voltage and air conditioners dedicated circuit for the power supply, and the power cord diameter must meet the national requirements.
- Be sure to use the rated voltage and air conditioners dedicated
- When the maximum current of air conditioner is $\geq 16A$, it must use the air switch or leakage protection switch equipped with protection devices.
- The normal operating range is 90%-110% of the local rated voltage.
- The minimum clearance between the air conditioner and the combustibles is 1.5m
- The power cable enables communication between the indoor and outdoor units. You must first choose the right cable size before preparing it for connection.

Installation

Grounding Requirements

- The air conditioner is the type I electrical appliance and must ensure a reliable grounding.
- Do not connect the grounding wire to a gas pipe, water pipe, lightning rod, telephone line, or a circuit poorly grounded to the earth.
- The grounding wire is specially designed and shall not be used for other purpose, nor shall it be fastened with a common tapping screw.

Others

- The connection method of the air conditioner and the power cord and the interconnection method of each independent element shall be subject to the wiring diagram affixed to the machine.
- The model and rating value of the fuse shall be subject to the silkscreen on corresponding controller or fuse sleeve.

Installation

Installation of Indoor Unit

Installation Parts-checking

Packing list of the indoor unit

NO.	Name	Quantity	Unit
1	Indoor Unit	1	Set
2	Remote Controller	1	PC
3	Batteries(7#)	2	PC
4	Instructions	1	Set
5	Drain pipe	1	PC

NOTE:

※ All accessories shall be subject to actual packaging material, and if there is any difference, please understand.

Selection of Installation location

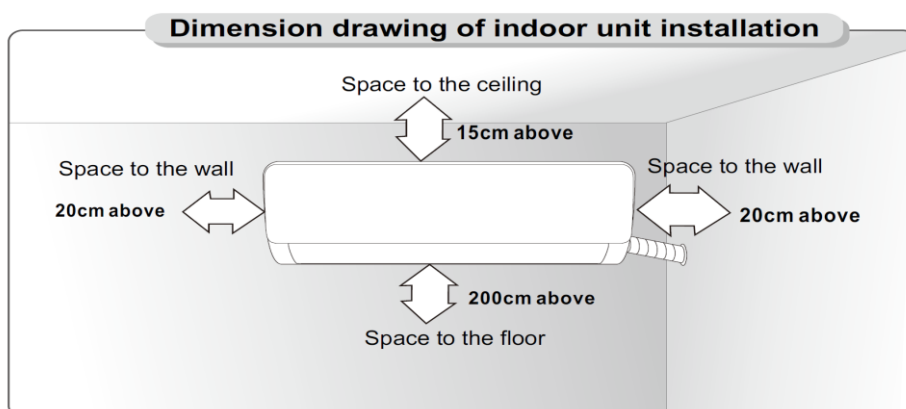

Mounting plate

1. The wall for installation of the indoor unit shall be hard and firm, so as to prevent vibration.
2. Use the "+" type screw to fasten the peg board, horizontally mount the peg board on the wall, and ensure the lateral horizontal and longitudinal vertical.
3. Pull the peg board by hand after the installation, to confirm whether it is solid.

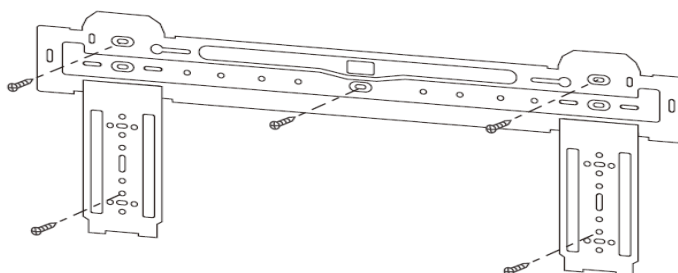

Installation

Wall-through Hole

1. Make a hole with an electric hammer or a water drill at the predetermined position on the wall for piping, which shall slant outwardly by 5°-10°.
2. To protect the piping and the cables from being damaged running through the wall, and from the rodents that may inhabit in the hollow wall, a pipe protecting ring shall be installed and sealed with putty.

Note: Usually, the wall hole is $\Phi 60\text{mm} \sim \Phi 80\text{mm}$. Avoid pre-buried power wire and hard wall when making the hole.

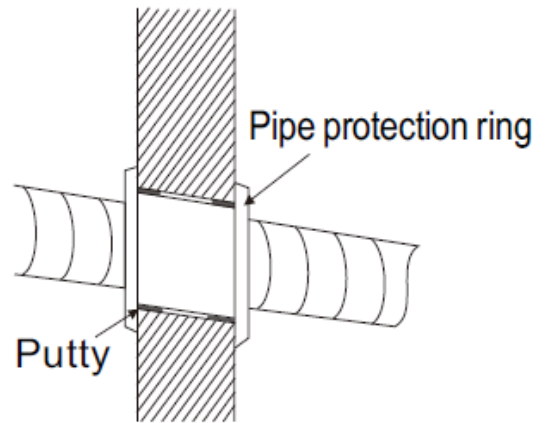

Route of Pipeline

1. Depending on the position of the unit, the piping may be routed sideway from the left or the right (Fig 1), or vertically from the back(Fig 2)(depending on the pipe length of the indoor unit). In the case of sideway routing, cut off the outlet cutting stock of the opposite side.
2. The power cord may be routed separately from the piping. Cut off the outlet cutting stock and then run the power cord through the hole, keeping the remaining part as a protection from rodents.

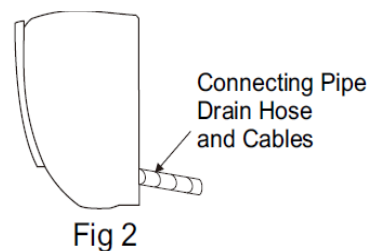
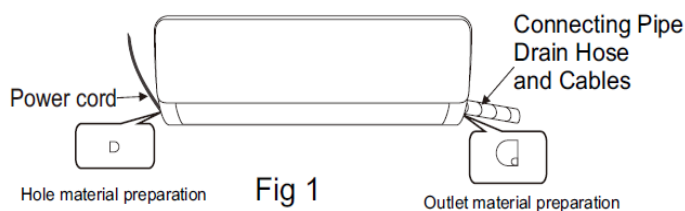

Installation

Drain pipe connection

1. Remove the mountings and pull the indoor unit pipe out of the housing.
2. Connect the connecting pipe to the indoor unit: Aim at the pipe center, tighten the Taper nut with fingers, and then tighten the T 12 nut with a torque wrench, and the direction is shown in diagram on the right. The torque used is shown in the following table

Tightening torque table

The size of pipe(mm)	Torque(N·m)
Φ6/Φ6.35	15 ~ 25
Φ9 /Φ9.5 2	35 ~ 40
Φ12/Φ12.7	45 ~ 60
Φ15.88	73 ~ 78
Φ19.05	75 ~ 80

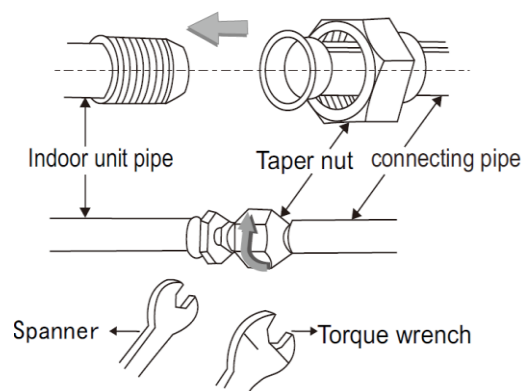

Wrap the Piping

1. Use the insulation sleeve to wrap the joint part the indoor unit and the connection pipe, and then use insulating material to pack and seal insulation pipe, to prevent generation of condensate water on the joint part.
2. Connect the water outlet with drain pipes, and make the connection pipe, cables, and the drain hose straight.
3. Use plastic cable ties to wrap the connecting pipes, cables and drain hose. Run the pipe sloping downward.

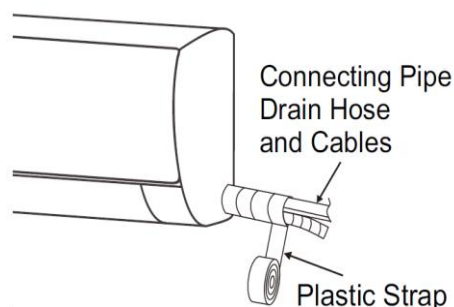

Fixing the indoor unit

1. Hang the indoor unit on the peg board, and move the unit from left to right to ensure that the hook is properly positioned in the peg board.
2. Push toward the lower left side and the upper right side of the unit toward the peg board, until the hook is embedded in the slot and makes a "click" sound.

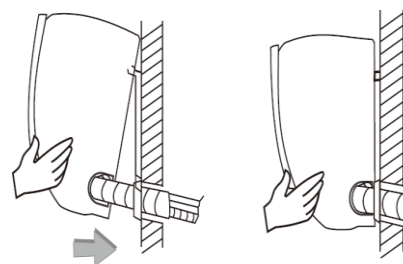

Electric Connection Requirement

1. Loosen the screws and remove from the unit.
2. Connect the cables respectively to the corresponding terminals of the terminal board of the indoor unit (see the wiring diagram), and if there are signals connected to the plug, just conduct butt joint.
3. Ground wire: Remove the grounding screw out of the electric bracket, cover the grounding wire end onto the grounding screw and screw it into the grounding hole.
4. Fix the cable reliably with fasteners (Pressing board).
5. Put the E-parts cover back in its original place and fasten it with screws.

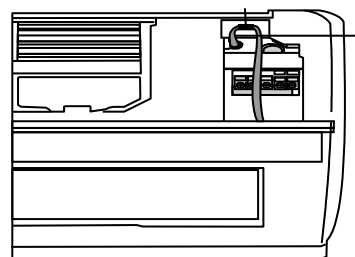

Installation

Wiring Diagram

12&18K

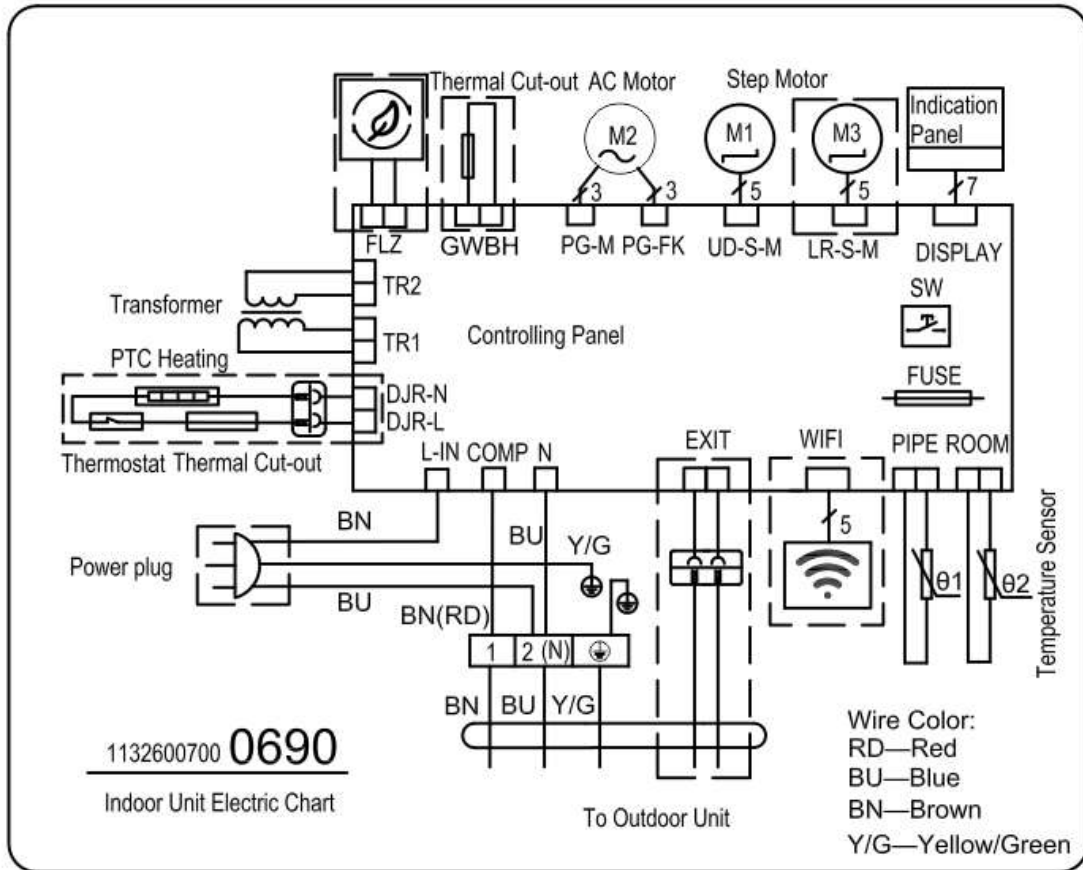

Installation

24K & 30K & 36K

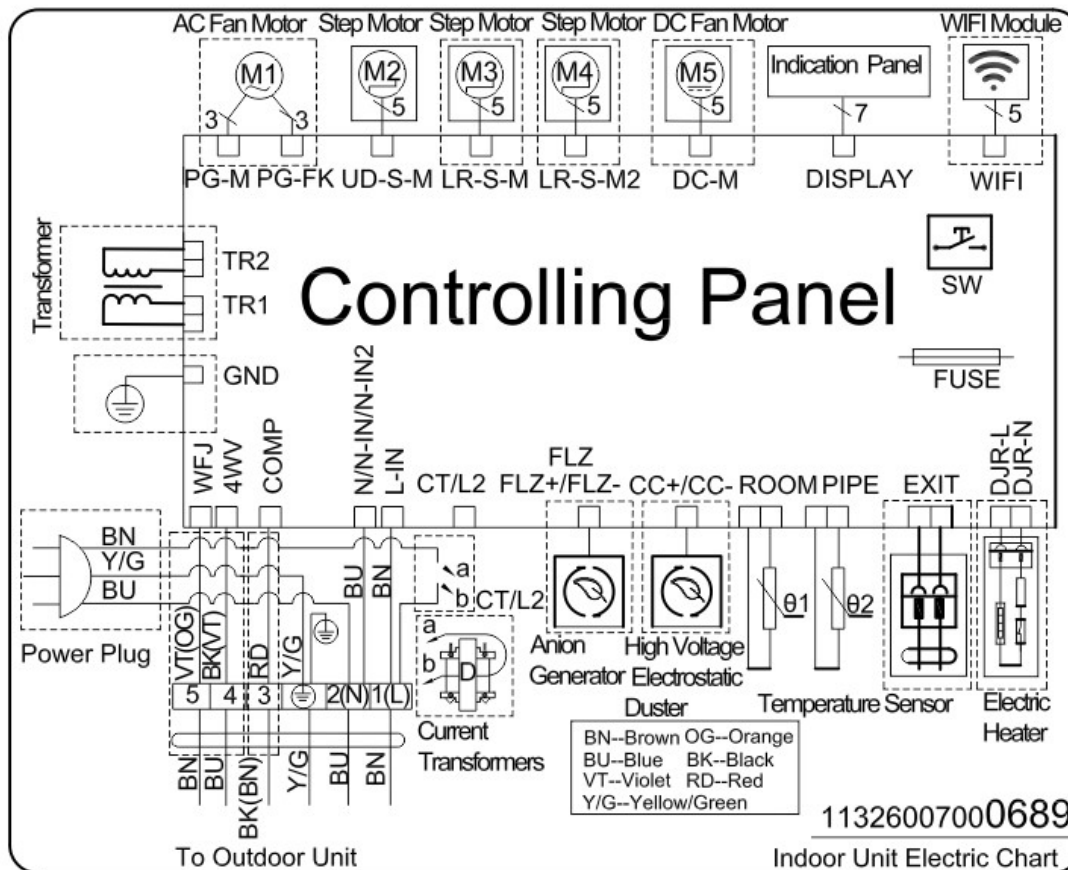

NOTE:

- This manual usually includes the wiring mode for the different kind of A/C. We cannot exclude the possibility that some special type of wiring diagrams are not included.
- The diagram are for reference only. If the entity is difference with this wiring diagram, please refer to the detailed wiring diagram adhered on the unit which you purchased.

Installation

Installation of outdoor Unit

Packing list of the outdoor unit

NO.	Name	Quantity	Unit
1	Outdoor Unit	1	Set
2	Connecting pipe	2	PC
3	Plastic Strap	1	ROLL
4	Pipe Protection Ring	1	Set
5	Luting (putty)	1	PACKET

Selection of Installation location

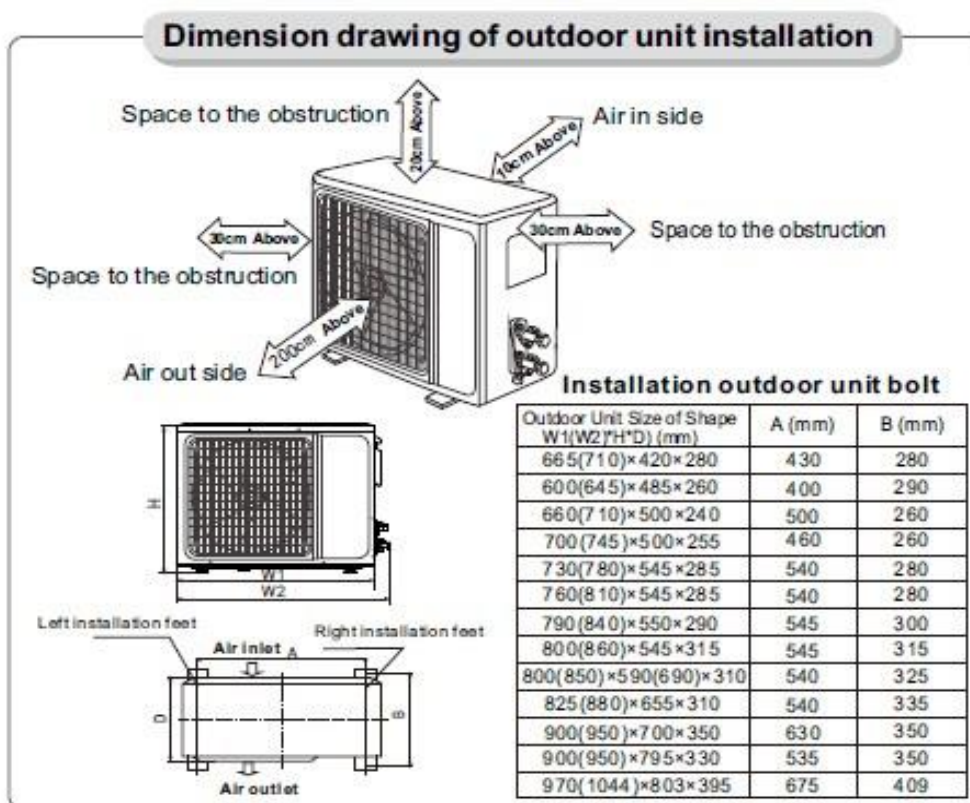

Installation

Install the connection pipe

Connect the Outdoor Unit with Connecting Pipe: Aim the counter-bore of the connecting pipe at the stop valve, and tighten the Taper nut with fingers. Then tighten the Taper nut with a torque wrench.

- When prolonging the piping, extra amount of refrigerant must be added so that the operation and performance of the air conditioner will not be compromised.

Piping length	Amount of refrigerant to be added	
≤5M	Not needed	
5- 15M	CC≤12000Btu	20g/m
	CC≥18000Btu	30g/m

Note: This table is for reference only.

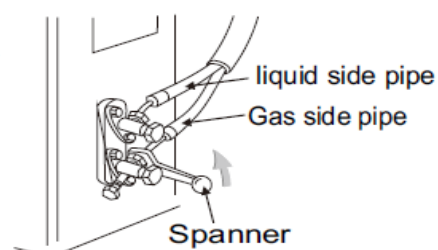
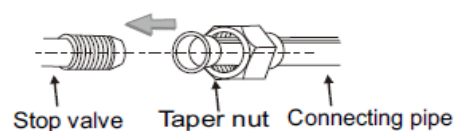

Wiring Connection

1. Loosen the screws and remove E-parts cover from the unit.
2. Connect the cables respectively to the corresponding terminals of the terminal board of the outdoor unit (see the wiring diagram), and if there are
3. signals connected to the plug, just conduct butt joint.
4. Ground wire: Remove the grounding screw out of the electric bracket, cover the grounding wire end onto the grounding screw and screw it into the grounding hole.
5. Fix the cable reliably with fasteners (Pressing board).
6. Put the E-parts cover back in its original place and fasten it with screws.

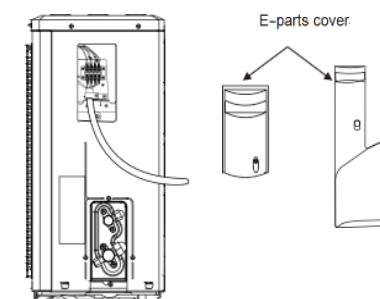

Installation

Wiring Diagram

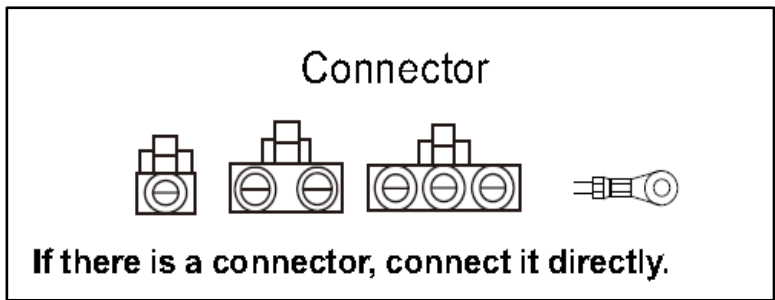
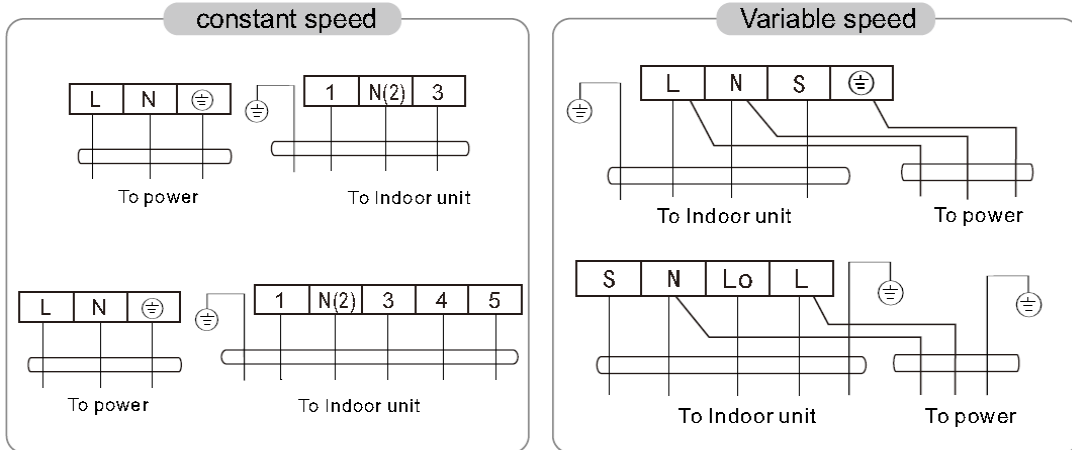

NOTE:

- This manual is usually includes the wiring mode for the different kind of A/C. We cannot exclude the possibility that some special type of wiring diagrams are not included.
- The diagram are for reference only. If the entity is difference with this wiring diagram, please refer to the detailed wiring diagram adhered on the unit which you purchased.

Expelling the air

Outdoor unit refrigerant discharging method

After the pipe side connection is complete, proceed as follows.

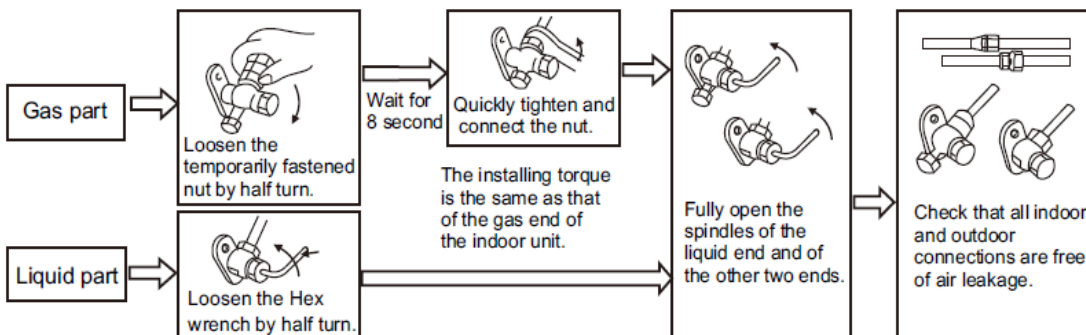

Installation

Vacuum Pumping Method (R410A refrigerant evacuation must use the vacuum pumping method)

Before working on the air conditioner, remove the cover of the stop valve(gas and liquid valves)and be sure to retighten it afterward.(to prevent the potential air leakage)

1. To prevent air leakage and spilling tighten all connecting nut of all flare tubes.
2. Connect the stop valve, charge hose, manifold valve, and vacuum pump.
3. Fully open the handle Lo of the manifold valve and apply vacuum for at least 15 minutes and check that the compound vacuum gauge reads 0.1MP a (-76cmHg).
4. After applying vacuum, fully open the stop valve with a hex wrench.
5. Check that both indoor and outdoor connections are free of air leakage.

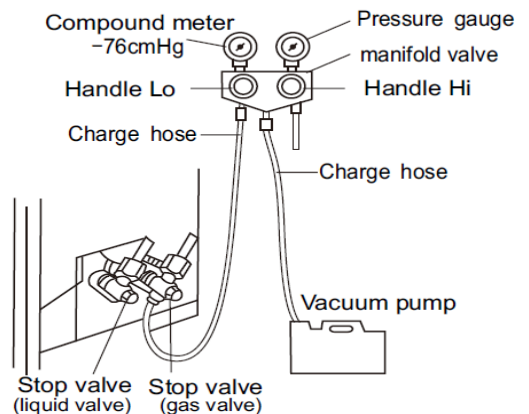

Outdoor condensation drainage(Heat pump type only)

When the unit is heating, the condensing water and defrosting water can be out reliably through the drain house.

Installation:

Install the outdoor drain elbow in $\Phi 25$ hole on the base plate, and joint the drain hose to the elbow, so that the waste water formed in the outdoor unit can be drained out to a proper plate.

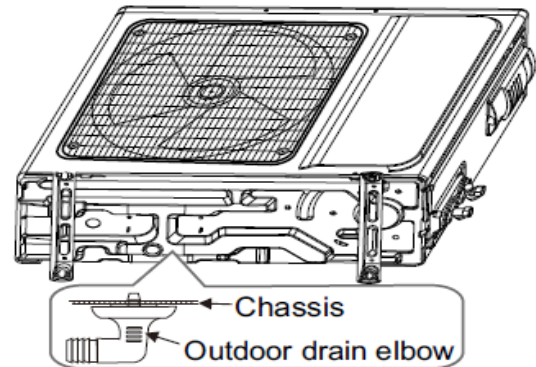

Installation

Check after installation and test operation

1. Check after installation

▪ Electrical Safety Check

- ① If the supply voltage is as required.
- ② If there is any faulty or miss connection in each of the power, signal and grounding wires.
- ③ If the grounding wire of the air conditioner is securely grounded.

▪ Installation Safety Check

- ① If the installation is secure.
- ② If the water drain is smooth.
- ③ If the wiring and piping are correctly installed.
- ④ Check that no foreign matter or tools are left inside the unit.

▪ Leak test of the refrigerant

Depending on the installation method, the following methods may be used to check for suspect leak, on areas such as the four connections of the outdoor unit and the cores of the cut-off valves and t-valves:

- ① Bubble method: Apply of spray a uniform layer of soap water over the suspected leak spot and observe carefully for bubble.
- ② Instrument method: Checking for leak by pointing the probe of the leak detector according to the instruction to the suspect points of leak.

2. Test operation

▪ Test preparation

- * Verify that all piping and connection cables are well connected.
- * Confirm that the valves at the gas side the liquid-side are fully open.
- * Connect the power cord to an independent power socket.
- * Install batteries in remote control.

▪ Test Operation method

- ① Turn on the power and push the ON/OFF switch button of the remote controller to start the air conditioner.
- ② Select COOL, HEAT (not available on cool-only models), SWING and other operation modes with the remote controller and see if the operation is ok.

Maintenance

Troubleshooting Guide

Many error codes many appears on this air conditioner, and this troubleshooting guide is prepared for the maintenance personnel to detect the error position and the parts to be replaced during the troubleshooting process. In this Guide, the Troubleshooting Method is guided by the Error Name, and the Reference Code under the General Index is the error code of the Indoor Unit unit of the mainstream model supplied by the Company.

General index:

No.	Error Name	Reference Code
1	Overcurrent Protection of Indoor Unit	E0
2	Indoor Unit temperature sensor error	E1
3	Outdoor Unit coil sensor error	E2
4	Indoor Unit coil sensor error	E3
5	Indoor Unit motor error of wall mounted air conditioner (PG motor)	E4
6	Indoor Unit motor error of wall mounted air conditioner (DC motor)	E4
7	Indoor EE Failure	Eb
8	High-pressure protection	P2
9	Liquid Deficiency Protection	P3

Example:

Explanation of error	Cause: explain the principle of the specific error. Inspection path: The basic order of troubleshooting. Related key position
Tools required for inspection	Tools that should be carried for such troubleshooting, and replacing parts that may be necessary for such error.
Frequent problematic	Any possibly broken part related to the error may be the parts that need to be replaced.
Inspection procedure and key points	All the troubleshooting procedures for the reference of maintenance staff are prepared from simple to complex, from surface to Indoor Unit, and from test to replacement. Although these key points do not cover all the error, and difficult or special problems are not included as well, but they can cover most of the common error.
Special attention	Here are some often-overlooked problems for the reference of the maintenance personnel.

Maintenance

The problems in the market are always more than we think, so it is necessary for the maintenance personnel to understand the principle of air conditioning operation, and to make a flexible judgment of the fault in combination with the actual conditions. We welcome the maintenance personnel to constantly put forward new problems in the actual work, record the solutions and enrich our troubleshooting guide list.

(1) E0 - Overcurrent Protection of Indoor Unit

Explanation of error	<p>Cause: The main PCB detects that the working current of the system exceeds the upper limit of protection, and will indicate "indoor unit overcurrent protection". The air conditioner stops running for protection and displays the failure code E0.</p> <p>Inspection path: current transformer → power line → compressor line → connector assembly</p>
Tools required for inspection	Current clamp and multimeter
Frequent problematic part	Indoor unit panel, power line, compressor and complete machine
Inspection procedure and key points	<ol style="list-style-type: none"> 1. If it is a fixed-frequency model, observe whether the live line passes through the current transformer; if not, lay the line accordingly and reboot for inspection. 2. The current clamp is used to measure the working current and determine whether it is within the normal working current range of the nameplate. If normal working current is detected, it may be the fault of the current transformer and replace the main PCB of the indoor unit. 3. Measure whether the power supply voltage is within the normal operating voltage range; if the working voltage is not normal, it is necessary to consider whether the local grid voltage is stable. 4. If the working current exceeds the range and the working voltage is normal, the system may be blocked and the air-conditioning may be overloaded, which needs to be checked according to the actual situation.

(2) E1-Indoor Unit temperature sensor error

Explanation of error	<p>Cause: The detection of short circuit or open circuit of Indoor Unit temperature sensor during the inspection of main PCB in the Indoor Unit machine, indicated by "Indoor Unit temperature sensor error".</p> <p>Inspection path: Sensor→Sensor wire→Connectors→Indoor Unit main PCB</p>
Tools required for inspection	Multimeter, 15KΩ standard sensor (25℃)

Maintenance

Frequent problematic part	Indoor Unit temperature sensor, Indoor Unit main PCB
Inspection procedure and key points	<ol style="list-style-type: none"> 1. Check whether there's resistance problem, short circuit or open circuit in the sensor; the resistance value shall be within a reasonable range (15KΩ under the temperature of 25℃) 2. Check whether the sensor wire is broken. 3. Check whether the terminal connectors are well fixed; check whether the weld between the terminal and the main PCB is loose, and pull the terminal slightly for inspection if necessary. 4. Check whether the sensor is affected with damp. 5. In case no standard sensor is available at present, replace the Indoor Unit temperature sensor by other sensor asides, and then check whether the error still exists; if the error disappears, replace the sensor; if the error still exists, check the Indoor Unit main PCB and change if necessary.
Special attention	<p>Most Indoor Unit temperature sensors have a resistance value of 15KΩ. Do not use improper sensor during repairing and maintenance, or it may led to the wrong temperature sensing of the machine, the start error or shutdown error. You can switch the air conditioner to the “Blowing” mode, and judge the accuracy of sensor though environmental temperature displayed on the screen.</p> <p>In case a sensor with the resistance value over 15KΩ is used, the detected temperature will be much lower than the actual temperature, which may lead to the shutdown error under heating mode, or the startup error under cooling mode.</p> <p>In case a sensor with the resistance value below 15KΩ is used, the detected temperature will be much higher than the actual temperature, which may lead to the startup error under heating mode, or the shutdown error under cooling mode.</p>

(3) E2 -Outdoor Unit coil sensor error

Explanation of error	<p>Cause: The detection of short circuit or open circuit of Outdoor Unit coil sensor during the inspection of Outdoor Unit main PCB, indicated by “Outdoor Unit coil sensor error”.</p> <p>Inspection path: Sensor→Sensor wire→Connectors→Outdoor Unit main PCB</p>
Tools required for inspection	Multimeter, 20KΩ standard sensor (25℃)

Maintenance

Frequent problematic part	Indoor Unit temperature sensor, Indoor Unit main PCB
Inspection procedure and key points	<ol style="list-style-type: none"> 1. Check whether there's resistance problem, short circuit or open circuit in the sensor; the resistance value shall be within a reasonable range (15KΩ under the temperature of 25℃) 2. Check whether the sensor wire is broken. 3. Check whether the terminal connectors are well fixed; check whether the weld between the terminal and the main PCB is loose, and pull the terminal slightly for inspection if necessary. 4. Check whether the sensor is affected with damp. 5. In case no standard sensor is available at present, replace the Indoor Unit temperature sensor by other sensor asides, and then check whether the error still exists; if the error disappears, replace the sensor; if the error still exists, check the Indoor Unit main PCB and change if necessary.
Special attention	<p>Most Indoor Unit temperature sensors have a resistance value of 15KΩ. Do not use improper sensor during repairing and maintenance, or it may led to the wrong temperature sensing of the machine, the start error or shutdown error. You can switch the air conditioner to the "Blowing" mode, and judge the accuracy of sensor though environmental temperature displayed on the screen.</p> <p>In case a sensor with the resistance value over 15KΩ is used, the detected temperature will be much lower than the actual temperature, which may lead to the shutdown error under heating mode, or the startup error under cooling mode.</p> <p>In case a sensor with the resistance value below 15KΩ is used, the detected temperature will be much higher than the actual temperature, which may lead to the startup error under heating mode, or the shutdown error under cooling mode.</p>

(3) E2 -Outdoor Unit coil sensorerror

Explanation of error	<p>Cause: The detection of short circuit or open circuit of Outdoor Unit coil sensor during the inspection of Outdoor Unit main PCB, indicated by "Outdoor Unit coil sensor error".</p> <p>Inspection path: Sensor→Sensor wire→Connectors→Outdoor Unit main PCB</p>
Tools required for inspection	Multimeter, 20KΩ standard sensor (25℃)

Maintenance

Frequent problematic part	Outdoor Unit coil sensor, Outdoor Unit main PCB
Inspection procedure and key points	<ol style="list-style-type: none"> 1. Check whether there's resistance problem, short circuit or open circuit in the sensor; the resistance value shall with a reasonable range (about 20KΩ) 2. Check whether the sensor wire is broken. 3. Check whether the terminal connectors are well fixed; check whether the weld between the terminal and the main PCB is loose, and pull the terminal slightly for inspection if necessary. 4. Check whether the sensor is affected with damp. The coil sensor is quite easy to be affected with damp in case the lead of coil sensor is above the copper pipe. 5. In case no standard sensor is available at present, replace the temperature sensor of Outdoor Unit coil by other sensor asides, and then check whether the error still exists; if the error disappears, replace the sensor; if the error still exists, check the Indoor Unit main PCB and change if necessary.
Special attention	<p>Most Indoor Unit temperature sensors have a resistance value of 20KΩ. Do not use improper sensor during repairing and maintenance, or it may led to the start of protection mode due to wrong temperature sensing of the machine, or the protection error. In case a sensor with the resistance value over 20KΩ is used, the detected temperature will be much lower than the actual temperature, which may lead to the frequent entering of defrost mode, the illusory defrosting or the protection error during the cooling process. In case a sensor with the resistance value below 20KΩ is used, the detected temperature will be much higher than the actual temperature, which may lead to defrost error during the heating process, or the start of protection during the cooling process.</p>

(4) E3 -Indoor Unit coil sensor error

Explanation of error	<p>Cause: The detection of short circuit or open circuit of Indoor Unit coil sensor during the inspection of Indoor Unit main PCB, indicated by "Indoor Unit coil sensor error".</p> <p>Inspection path: Sensor→Sensor wire→Connectors→Indoor Unit main PCB</p>
Tools required for inspection	Multimeter,, 5KΩ or 20KΩ standard sensee (25℃)

Maintenance

<p>Frequent problematic part</p>	<p>Indoor Unit temperature sensor, Indoor Unit main PCB</p>
<p>Inspection procedure and key points</p>	<ol style="list-style-type: none"> 1. Check whether there's resistance problem, short circuit or open circuit in the sensor; the resistance value shall with a reasonable range (about 20KΩ) 2. Check whether the sensor wire is broken. 3. Check whether the terminal connectors are well fixed; check whether the weld between the terminal and the main PCB is loose., and pull the terminal slightly for inspection if necessary. 4. Check whether the sensor is affected with damp. The coil sensor is quite easy to be affected with damp in case the lead of coil sensor is above the copper pipe. 5. In case no standard sensor is available at present, replace the temperature sensor of Indoor Unit coil by other sensor asides, and then check whether the error still exists; if the error disappears, replace the sensor; if the error still exists, check the Indoor Unit main PCB and change if necessary.
<p>Special attention</p>	<p>Most Indoor Unit temperature sensors have a resistance value of 20KΩ. Do not use improper sensor during repairing and maintenance, or it may led to the start of anti-frosting or overheat protection mode due to wrong temperature sensing of the machine.</p> <p>In case a sensor with the resistance value over 20KΩ is used, the detected temperature will be much lower than the actual temperature, which may lead to the high pressure of cold-blast protection system during the heating process, or the frequent start of anti-freezing protection during the cooling process.</p> <p>In case a sensor with the resistance value below 20KΩ is used, the detected temperature will be much higher than the actual temperature, which may lead to the frequent start of overheat protection mode during the heating or the overload protection during the cooling process.</p>

Maintenance

(5) E4 -Indoor Unit motor error of wall mounted air conditioner (PG motor)

<p>Explanation of error</p>	<p>Cause: PG motor is equipped with speed feedback signal line. When the feedback signal of speed is not received by the Indoor Unit main PCB, it has no way to recognize the rotating speed of motor, which will be indicated as “Indoor Unit motor error”. Main causes for the disappearance of speed feedback signal are as follows:</p> <ol style="list-style-type: none"> 1. The fan is stucked; 2. The speed feedback component in the motor is broken; 3. Error of receiving circuit for the speed feedback signal from the Indoor Unit main PCB.
<p>Tools required for inspection</p>	<p>Multimeter, A PG motor in normal working condition</p>
<p>Frequent problematic part</p>	<p>Mechanical jam problem of Indoor Unit motor, PG motor, Indoor Unit main PCB</p>
<p>Inspection procedure and key points</p>	<ol style="list-style-type: none"> 1. Check whether the motor can work for a period of time before the error occurs. If yes, the reason of mechanical jam can be exclude. 2. Disconnect the power supply and move the fan blade of Indoor Unit machine by hand to see if there’s any resistance. Some occasional Indoor Unit motor error may relate to bearing coordination. 3. Reconnect the drive wire and speed feedback wire, thus to exclude any motor error due to connector loosening. 4. Check whether the plug-in terminal of speed feedback on the PCB is loose, and pull the terminal slightly for inspection if necessary. 5. Replace the motor in the faulted air conditioner with other PG motor (do not fix it with the fan for the time being), if the main PCB still indicates “Indoor Unit motor error”, then replace the Indoor Unit main PCB; if the error disappears, replace the Indoor Unit motor.
<p>Special attention</p>	<p>The Indoor Unit main PCB will not indicates “Indoor Unit motor error” when the Indoor Unit motor is still rotating; sometimes such error will not be reported when obvious motor problems exist (such as the low-speed rotation due to damaged motor capacitors, or non-uniform rotating speed due to abnormal speed feedback.</p> <p>Therefore, patience of the maintenance staff is required for the troubleshooting of motor error. You shall compare it with the normal condition, and detect and solve the problem in a flexible way.</p>

:

:

:

Maintenance

(6) E4- Indoor Unit motor error of wall mounted air conditioner (DC motor)

<p>Explanation of error</p>	<p>Cause: The Indoor Unit motor of some highly energy efficient models is DC motor using a green plug through which the Indoor Unit main PCB can drive the motor and sense the current rotational speed feedback. When the Indoor Unit main PCB cannot receive the rotational speed feedback signal of the motor, it will indicate “DC motor error”. Disappearance of the rotational speed feedback signal may be caused by:</p> <ol style="list-style-type: none"> 1 The fan is stuck and cannot work; 2 The speed feedback element inside the motor is destroyed; 3 There’s something wrong with the speed feedback signal receiving circuit of the Indoor Unit main PCB. <p>Inspection path: Is DC motor stuck by foreign matter→motor destroyed → Motor terminal connectors→Indoor Unit main PCB</p>
<p>Tools required for inspection</p>	<p>Multimeter, a DC motor in normal working condition</p>
<p>Frequent problematic part</p>	<p>Mechanical jam of Indoor Unit motor, Indoor Unit DC motor, Indoor Unit main PCB</p>
<p>Inspection procedure and key points</p>	<ol style="list-style-type: none"> 1. Check whether the motor accelerates to extremely high speed before the error occurs. If it can work for a period, the reason of mechanical jam can be excluded. 2. Plug and unplug the terminal of the DC motor again to exclude any motor error due to connector loosening, and pull the terminal slightly for inspection if necessary. 3. Replace the motor in the faulted air conditioner with other DC motor to plug in the Indoor Unit main PCB (do not fix it with the fan for the time being), if the main PCB still indicates “DC motor error”, then replace the Indoor Unit main PCB; if the error disappears, replace the DC motor. 4. Multimeter can be used to distinguish whether it is main PCB problem or motor problem by: connect the motor with the main PCB and pay attention to the second (yellow) and fourth (black) wire from the outermost side among four lines of the terminal of the DC motor. After the air conditioner powers on in the cooling mode for a while, the voltage between the yellow and black wires should rise gradually and the motor should accelerates slowly, if the DC motor still won’t rotate, then the DC motor is destroyed.
<p>Special attention</p>	<p>Five lead wires division: Count from the outermost side of the four wires of the DC motor terminal, the first blue wire is the speed feedback wire with a voltage of 0.5-5V when the motor rotates; the second yellow wire is the motor driving wire with a voltage of 2.0-7.5V when the motor rotates; the second white wire is 15V power cord with a voltage of 15V in normal condition; the fourth black wire is 0V DC earth wire which is the benchmark of all the voltage tests; the fifth (red) wire is 310V wire which is strong with a voltage of 310V in normal condition, so be careful of electric shock.</p>

Maintenance

(7) Eb- Indoor EE Failure

<p>Explanation of error</p>	<p>Cause: Many parameters need to be preset for the running of the indoor unit of the air conditioner and such parameters are placed in a data storage 8-foot chip, which is called "EEPROM" or "EE" for short. The motor on the Indoor Unit main PCB can only work after reading the data stored in EE and if not read, the failure code "Outdoor EE Failure" will be indicated and raised in the indoor unit. Reasons for data not being read are as follows:</p> <ol style="list-style-type: none"> 1. Wrong EE chip data format; 2. EE chip is broken; 3. Bad contact of EE or fault of EE reading circuit; 4. Backward installation of EE chip. <p>Inspection path: Indoor Unit main PCB.</p>
<p>Tools required for inspection</p>	<p>/</p>
<p>Frequent problematic part</p>	<p>Bad contact of EE, Indoor Unit main PCB.</p>
<p>Inspection procedure and key points</p>	<p>Replace the Indoor Unit main PCB directly.</p>

Maintenance

(8) P2- High-pressure protection

<p>Explanation of error</p>	<p>Cause: In standby state or when the equipment is running, the high-pressure switch is disconnected three times (within 20 minutes) and reported as "High-pressure protection"; Inspection path: high-pressure switch cable → connector → high-pressure switch → main PCB</p>
<p>Tools required for inspection</p>	<p>Multimeter, connectoin line and high-pressure swtich</p>
<p>Frequent problematic part</p>	<p>High-pressure swtich connectoin line, fluorine deficiency of unit and high-pressure swtich</p>
<p>Inspection procedure and key points</p>	<ol style="list-style-type: none"> 1. Check whether the plug-in terminals are firmly connected and whether the terminals and the main PCB are welded loosely. If necessary, gently pull them to check; 2. Use a multimeter to measure whether it is disconnected; 3. Use the multimeter to check the state of the high-pressure swtich and check whether it is in the OFF state (normally OFF, unusual disconnection); 4. If the pressure is normal and the high-pressure switch is kept open, it is positive that the pressure voltage is faulted; 5. If the pressure switch is normal and the connection line is tact and the failure is still reported, replace the corresponding main PCB.
<p>Special attention</p>	<p>The reason why high-pressure switches are often disconnected is the leakage of equipment. When the high voltage switch is off, first check whether the air conditioner's pressure is normal. If it is normal but the failure is still displayed after replacing the Outdoor Unit main PCB, it is possible that the connecting pipe may be too long or the Outdoor Unit ambinet temperature is too low</p>

Maintenance

(9) P3- Liquid Deficiency Protection

Explanation of error	<p>Cause: The liquid volume of the system is less than 30%, which leads to non-refrigeration and liquid shortage protection.</p> <p>Inspection path: whether the valves of the outdoor unit are opened → whether the evaporator, condenser, connectoin pipe are damaged or cracked → whether the environmental temperature sensor and the coil temperature sensor are damaged at the same time</p>
Tools required for inspection	<p>Hex nut, multimeter, pressure gauge</p>
Frequent problematic part	<p>Stop valve, evaporator, condenser and connection pipe</p>
Inspection procedure and key points	<ol style="list-style-type: none"> 1. Check the stop valve and turn it counterclockwise with hexagons to see if the valve is not open and the opening is not enough; 2. Check whether the evaporator, condenser and connection pipe are damaged or cracked, and focus on checking whether there is refrigerant leakage in the welding part and connection pipe joint; 3. Measure the temperature sensor with the multimeter at ambient temperature, and whether the coil temperature sensor has abnormal resistance at the same time.

Maintenance

Troubleshooting for Normal Malfunction

The Foremost Inspecting Items

- ① The input voltage must be within +10% tolerance of the rated Voltage. If it is not the case, the air-conditioner will probably not work normally.
- ② Check the connecting cord between indoor unit and outdoor unit to see if it is properly connected. The connecting must be done according to the wiring diagram, please also notice that even different models may have the connecting cord of the same specification. Please check if the marks at the connecting terminal and the marks on the cord can match, otherwise, the air-conditioner will not work normally.
- ③ If the following phenomena are found, the problem is not from the air-conditioner itself.

NO.	Problems	Causes
1	The motor is heard operating but the air-conditioner does not work when the indoor unit is powered on	Since the air-conditioner is powered on, it will come to working condition as long as you press the ON/OFF button of the remote control and the Signal is well received.
2	The compressor stops running but the indoor motor keeps working when it is at cooling mode with the indoor temperature higher than set temperature.	If you turn off the air-conditioner and restart it immediately, it will return to normal in 3 minutes, after that, the air-conditioner will automatically adjust the indoor motor speed to what you set.
3	The compressor works discontinuously at dehumidifying mode.	The air-conditioner will automatically control the working of the compressor according to the inside temperature.
4	The air-conditioner does not work while the LED display is on.	The TIMER is set with the A/C; it will be in hold on condition. If the TIMER setting is cancelled, the air-conditioner will return to normal working condition.
5	The compressor works discontinuously at cooling and dehumidifying mode , and the indoor motor slows down.	The compressor stops Indoor Unit or the Motor slows down to prevent the indoor heat exchanger from being frozen.

Maintenance

Fault Diagnosis by Symptom

① No Power Display

(1) Items

- Check if the input voltage is correct?
- Check if the AC power supply connecting is correct?
- Check if the output voltage of the manostat L7805 (IC2) is correct?

(2) Trouble shooting procedure

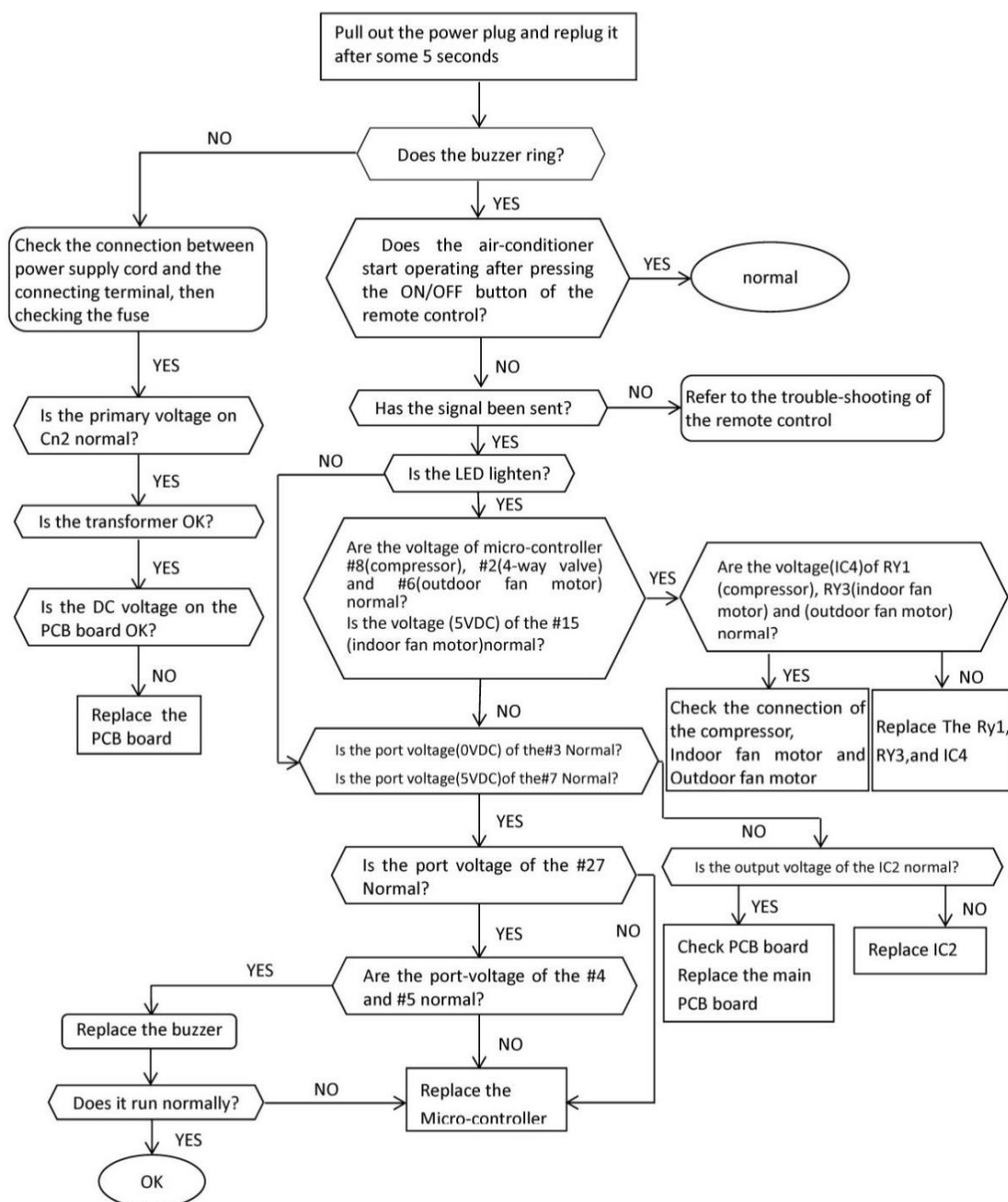

Maintenance

②The Indoor Motor Does Not Work

(1) Items

- Check if the indoor Motor is connected correctly to the connector (CN8)?
- Check if the AC input voltage is correct?
- Check if the IC of indoor Motor is connected correctly to the connector (CN2)?
- Check if the capacity of indoor Motor is connected correctly to the connector (CN8)?

(2) Trouble shooting procedure

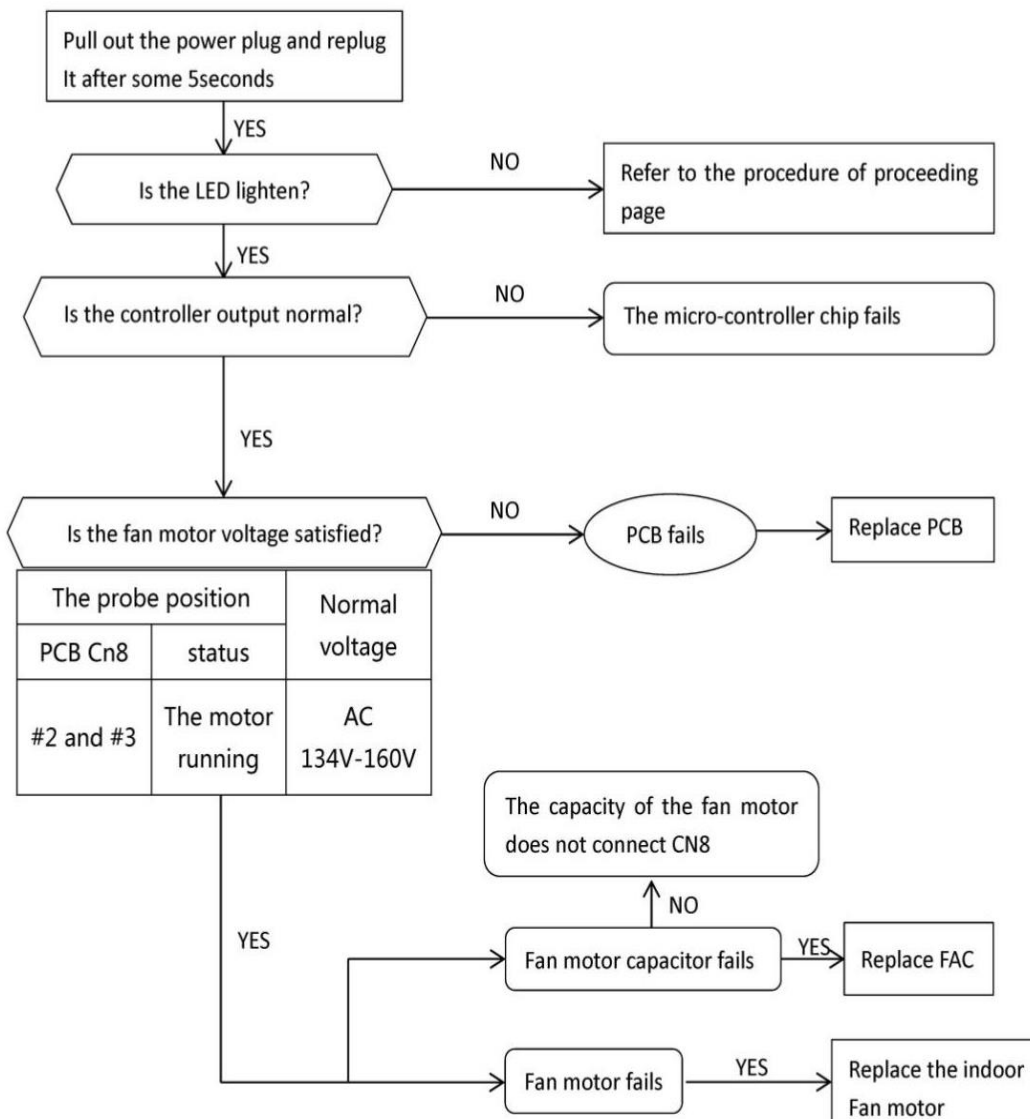

Maintenance

③ The Outdoor Unit Does Not Work

(1) Items

- a) Check if the input voltage is correct?
- b) Check if the wire connection of the outdoor connecting terminal is correct?

(2) Trouble shooting procedure

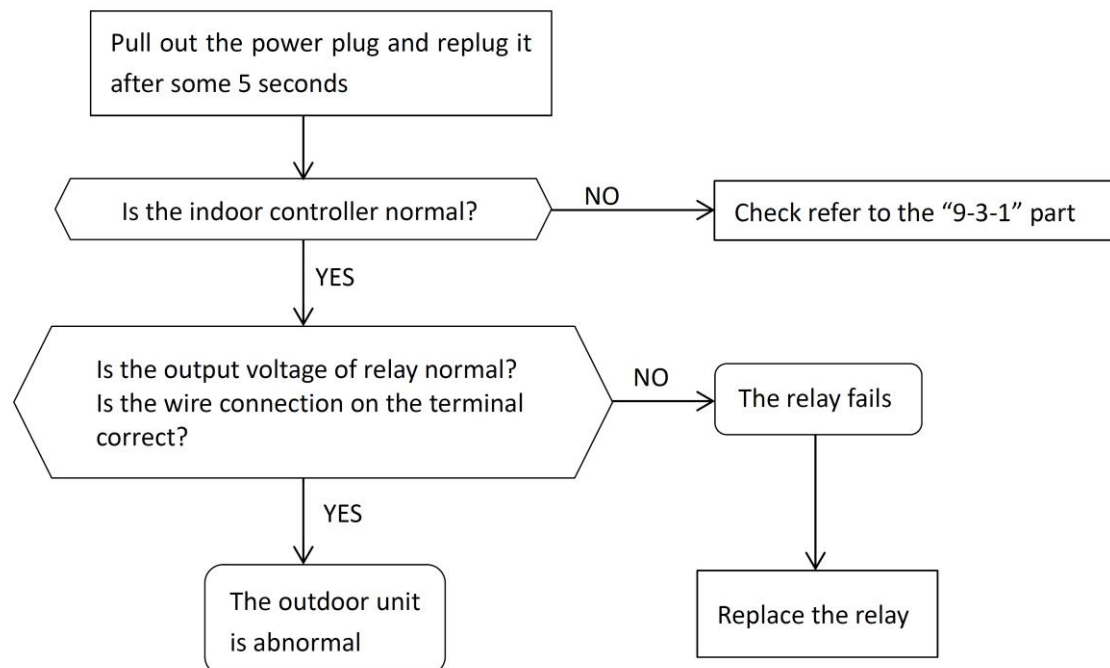

Maintenance

④ The Step Motor Does Not Work

(1) Items

- a) Check if the input voltage is correct?
- b) Check if the step motor controlling the up-down movement firmly connected to Cn2?

(2) Trouble shooting procedure

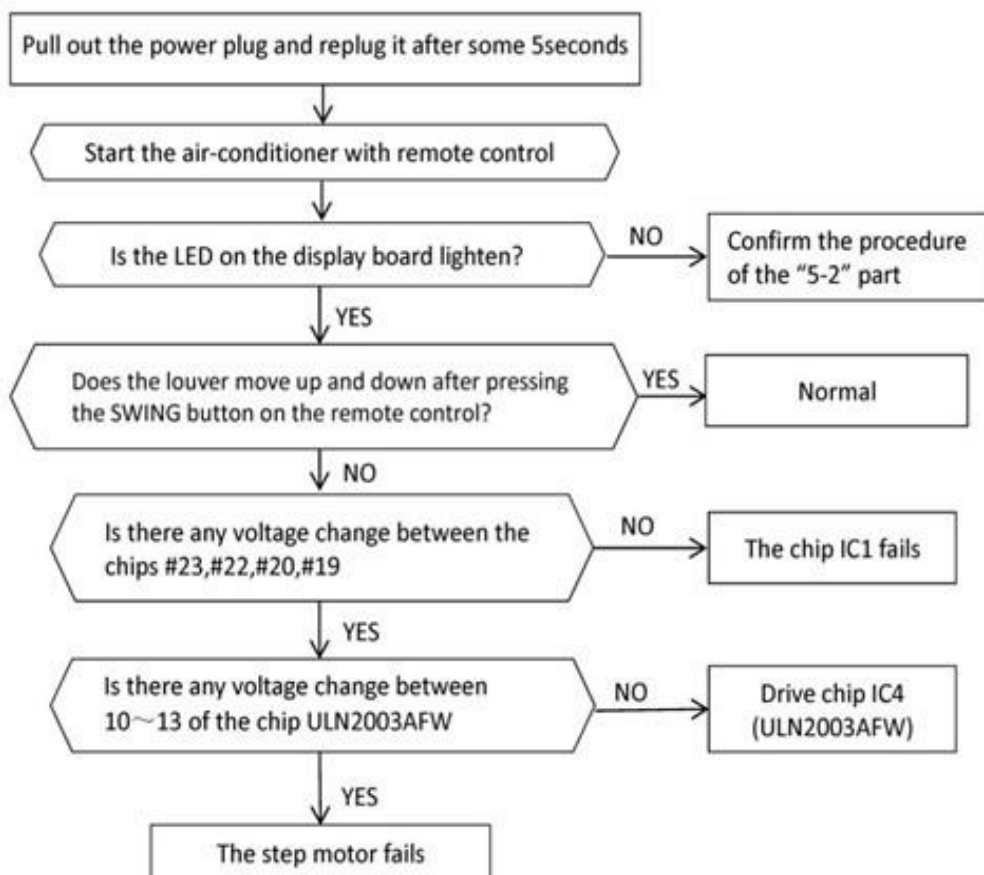

Maintenance

⑤ Heating Mode Can Work, But No Hot Air Blow

- (1) Check if the set temperature is lower than the indoor temperature?
- (2) Check if the indoor PCB is connected to the terminal correctly?

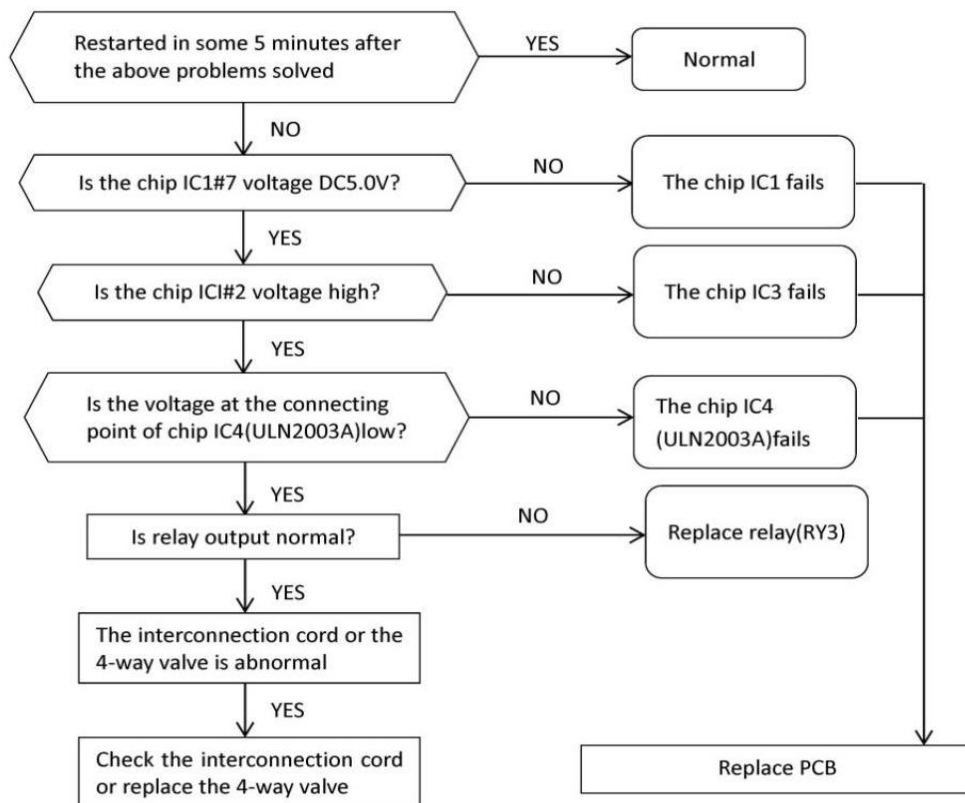

Maintenance

⑥ Remote Control Can Not Work

Trouble shooting procedure

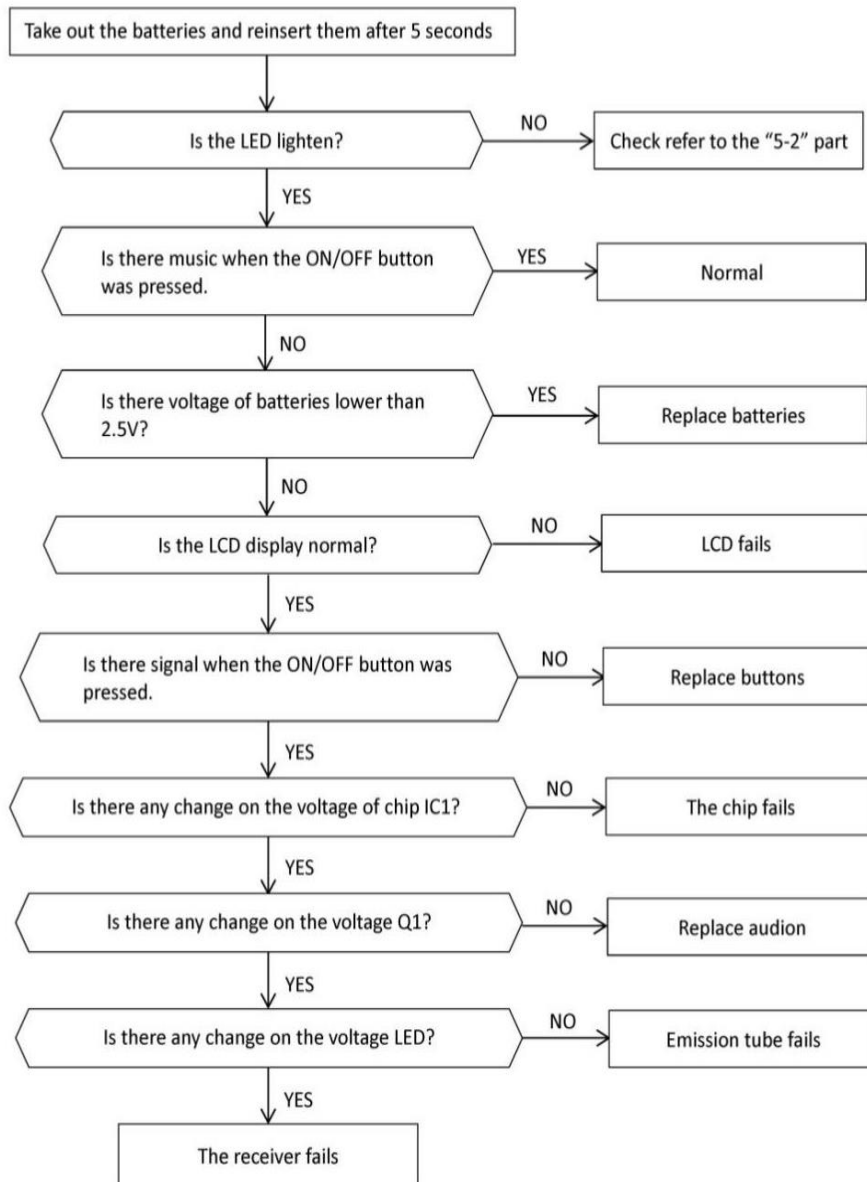



Trane optimizes the performance of homes and buildings around the world. A business of Ingersoll Rand, the leader in creating and sustaining safe, comfortable and energy efficient environments, Trane offers a broad portfolio of advanced controls and HVAC systems, comprehensive building services, and parts. For more information, visit www.Trane.com.

Trane has a policy of continuous product and product data improvements and reserves the right to change design and specifications without notice.

©2021Trane

Wall Mounted On-Off F Series_50Hz_202101001