

Hisense VRF

Hisense



Qingdao Hisense HVAC Equipment Co., Ltd.
Hisense Tower, Qingdao, China

<http://www.hisense-vrf.com> export@hisensehitachi.com [@HisenseVRFGlobal](#) [Hisense VRF](#) [Hisense VRF](#)



★ Design and specifications are subject to change without notice. Pictures and diagrams are for reference only and are subject to change without notice.
All rights reserved by Qingdao Hisense HVAC Equipment Co.,Ltd.



Reimagine your solution



Hisense SINCE 1969

Hisense Group is a well-known large-scale electronic information industry group company. Based on technology and focusing on innovation-oriented culture, its scientific and efficient technological innovation system makes Hisense always be at the forefront of the counterparts. Hisense brand family has continued to grow with Toshiba, Gorenje and ASKO. Multi-brand operations will be defined according to Group's Strategy Management Department.

SINCE 1969

BUSINESS LAYOUT

Multimedia

- TV and Display Devices
- Internet TV Operation
- Mobile Communication Devices
- Optical Communication Devices
- Chip

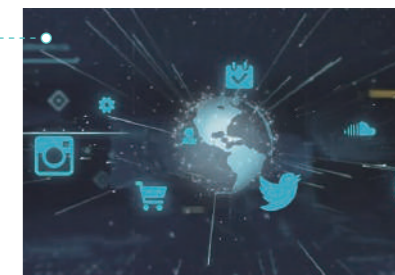

Household Appliances

- Refrigerator
- Freezer
- Air-conditioner
- Washing Machine
- Kitchen Appliance



IT Smart Systems

- Smart City
- Smart Community
- Smart Transportation
- Smart Business
- Medical Electronic Devices
- Smart Home System and Service

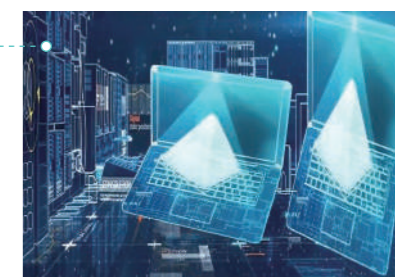

Real Estate & Modern Services

- Real Estate
- High-end Plaza Chains
- Mould Design and Manufacturing
- Finance
- Trade



GLOBAL MARKETING

Hisense has started a long-term sports marketing strategy to increase brand awareness worldwide. After the successful sponsorship of **UEFA EURO 2016** and **2018 FIFA WORLD CUP**, Hisense has made clear its focus on football. And now, Hisense becomes the official partner of **UEFA EURO 2020**.

2014
Official Sponsor of the Australian Open

2015
Title Sponsor of Hisense 300 NASCAR Xfinity Series and Team Sponsor of Joe Gibbs Racing

2016
Official Partner of UEFA EURO 2016

2018
Official Sponsor of the 2018 FIFA World Cup

2020
Official Partner of UEFA EURO 2020



Hisense VRF MANUFACTURING BASE

Qingdao Hisense HVAC Equipment Co., Ltd. is a wholly owned subsidiary of Qingdao Hisense Hitachi Air-conditioning Systems Co., Ltd., who is a joint-venture of Hisense and Hitachi (changed to Johnson Control Hitachi in 2015) and was established in 2003.

It integrates technology development for commercial and residential central air conditioners, product manufacturing, marketing and service as a whole. With the full support of all the shareholders such as Hisense and Johnson Control Hitachi, Hisense VRF is committed to becoming the market leader in the industry.

With solid technical innovation strength, Hisense VRF has participated in the formulation and revision of 38 national standards, industry standards and association standards, and has 659 authorized patents in the field of CAC and heat pump products. Since 2008, 58 technologies have reached the advanced level through authorized certification. Now Hisense VRF has become a leading CAC enterprise in China.

Note: The above data is valid before Dec. 31th, 2020.



266,000 m²
Manufacturing Area



40+
Production Line



6,000,000 units/year
Production Capacity



16,700 m²/70+
Laboratory



Why Hisense VRF?

Because It...

- Adopts newest technology.
- Owns comprehensive product lineup.
- Maintains high efficiency performance with reliable quality.
- Provides modular combination design.
- Assures convenient and fast transportation and installation.
- Meets intelligent control system.
- Serves as a local team of sale, technical supports and maintenance.
- Wins an excellent reputation all over the world.

Contents

01 Core
Technology

/ 11 Hisense VRF
Advantage

/ 29 Outdoor Unit
Specification

/ 51 Indoor
Unit

/ 85 Controller

/ 99 Accessory

Intelligent Self-cleaning Function

Sand accumulation on condenser coil can lead to decrease in the life of condenser coil and increase in energy consumption. With Hisense Innovative "Auto Self-cleaning Function", the condenser fan rotates in the reverse direction on every ON cycle to blow away dust.

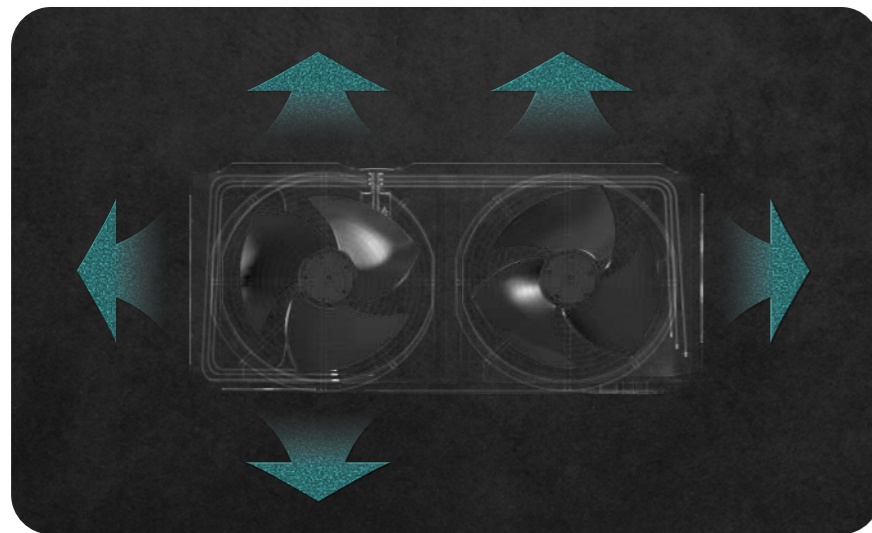

The sands and dust can be cleaned from different directions.

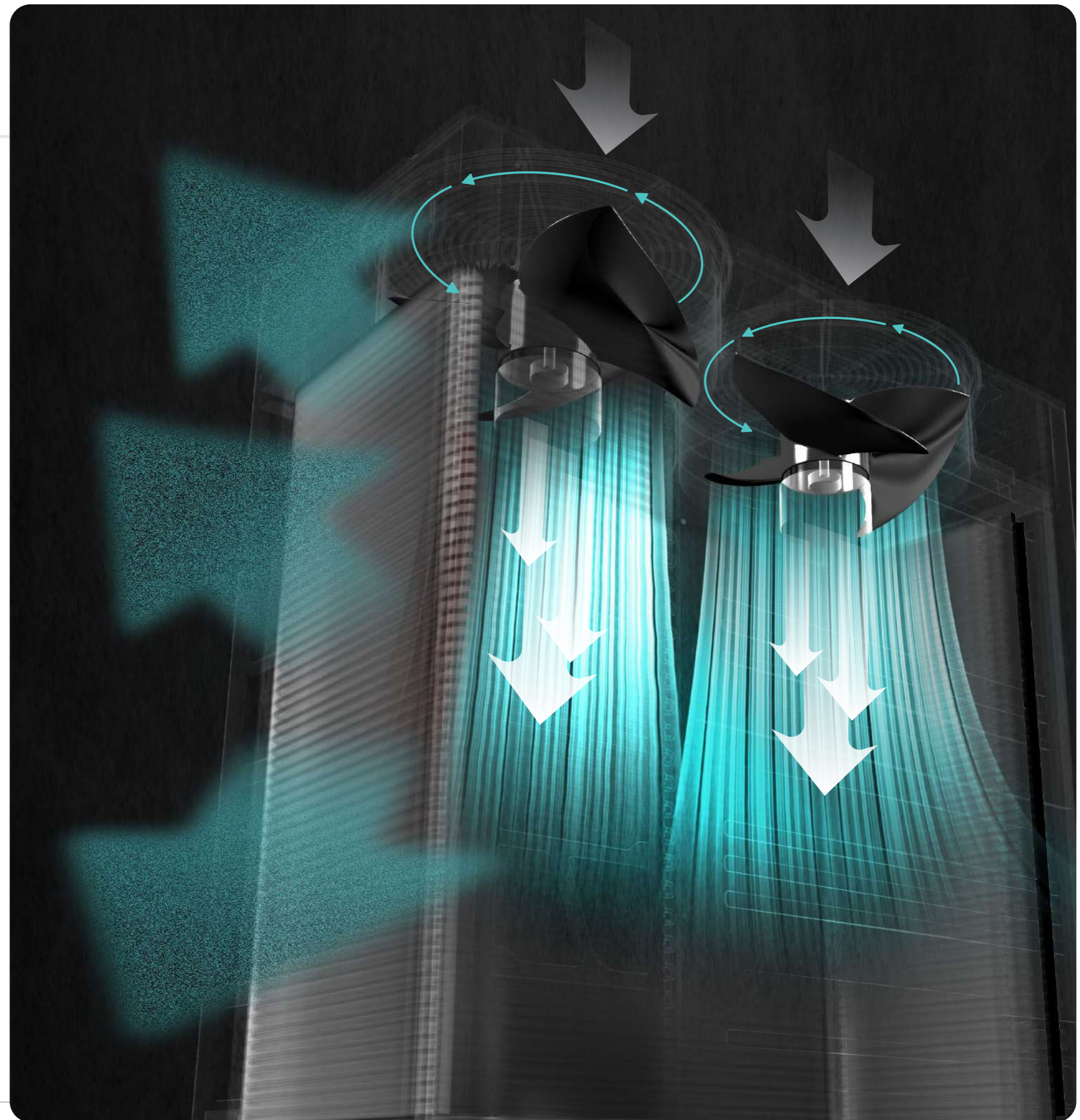

VIP Mode

Hisense outdoor units have VIP mode setting function. Under this mode, the system will satisfy the cooling need of the VIP room first.

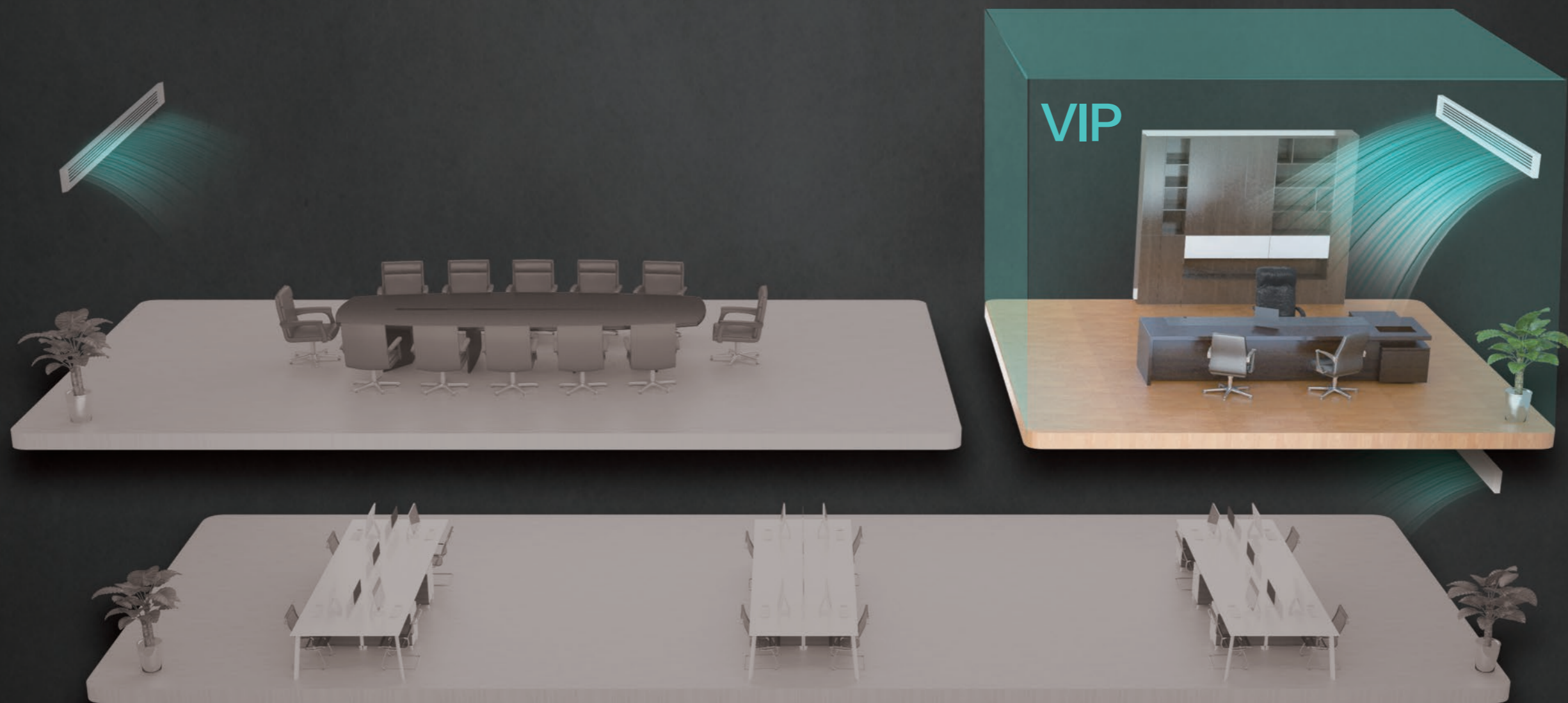

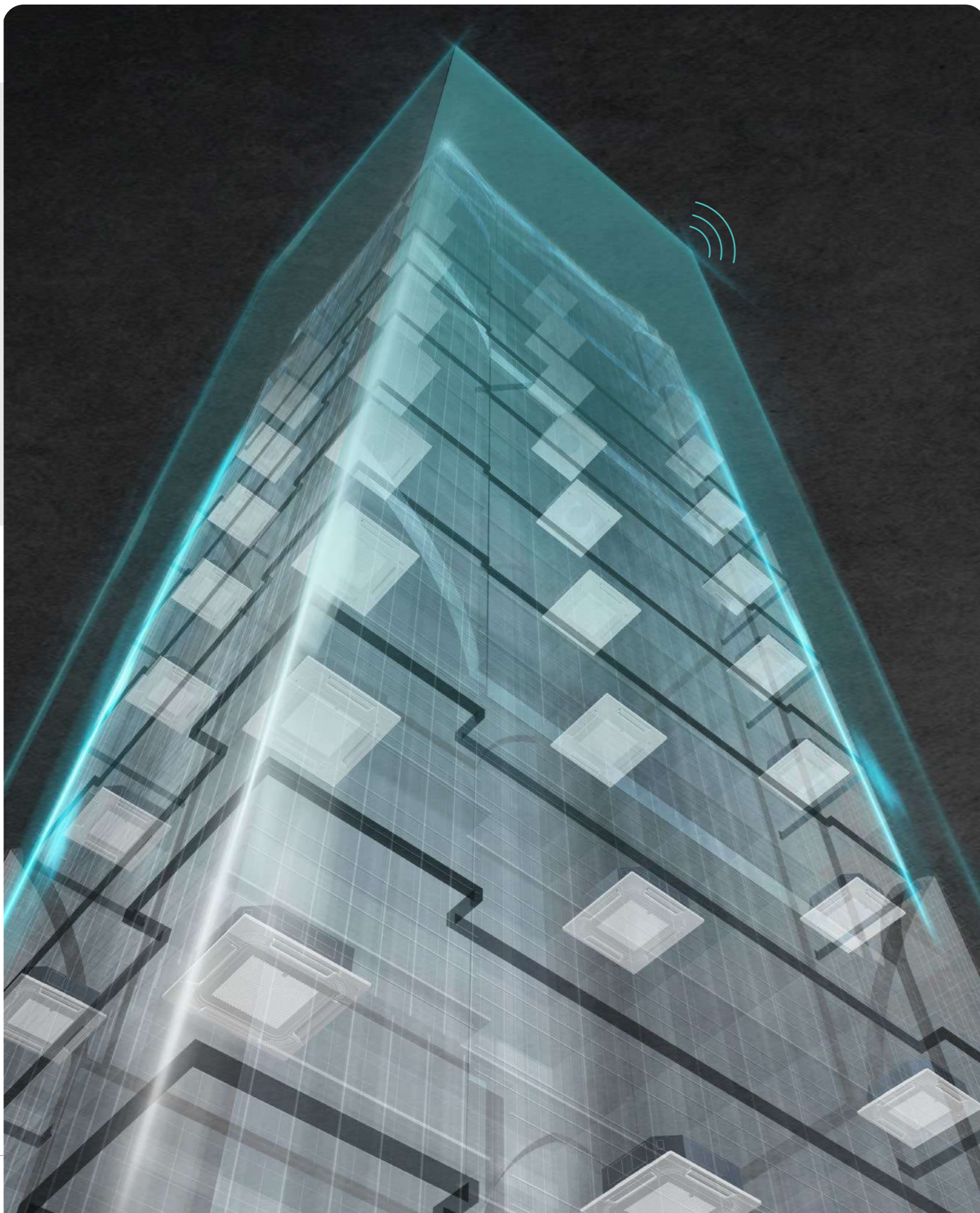

Hi-Motion



Hi-Mit II

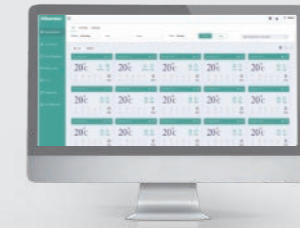

Hi-DOM III

Intelligent Control Hi-Dom III

Hi-Dom III air conditioning management system adopts communication bus connection; air conditioning indoor units are connected to the computer through network converter; the system is all controlled automatically by a computer with powerful functions and simple operation.

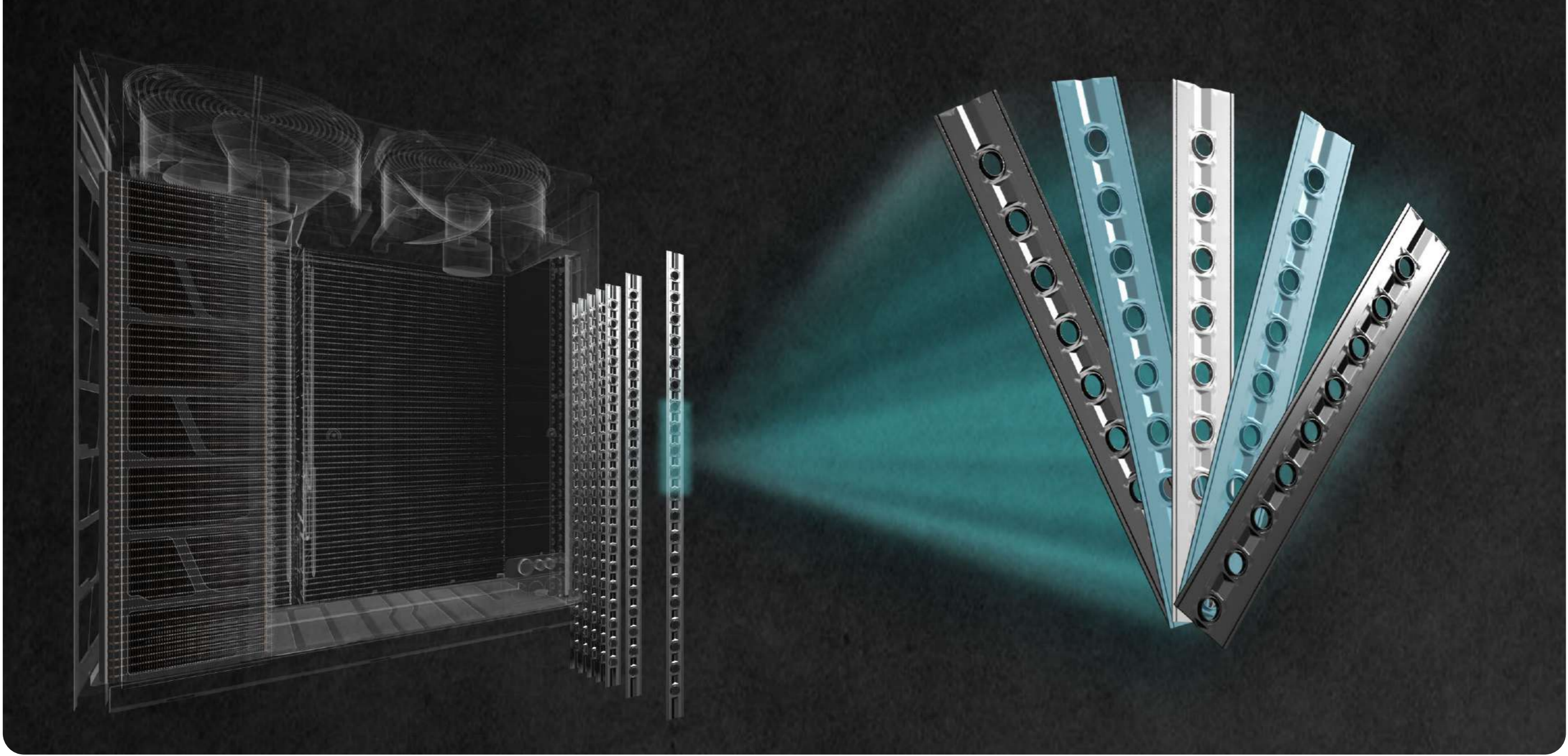

Hisense Anti-corrosion Black Fin (Optional)

Hisense anti-corrosive fins are coated with epoxy resin using film-forming techniques while the traditional resins are acrylic resins. The epoxy resin is 1.5 times thicker than acrylic resin, and its acid-resistant, alkali-resistant and salt-fog resistant properties is 3 times better than acrylic resin.

Hi Black Fin

The moisture facilitates ionization of Zinc. It will protect fins from corrosion.

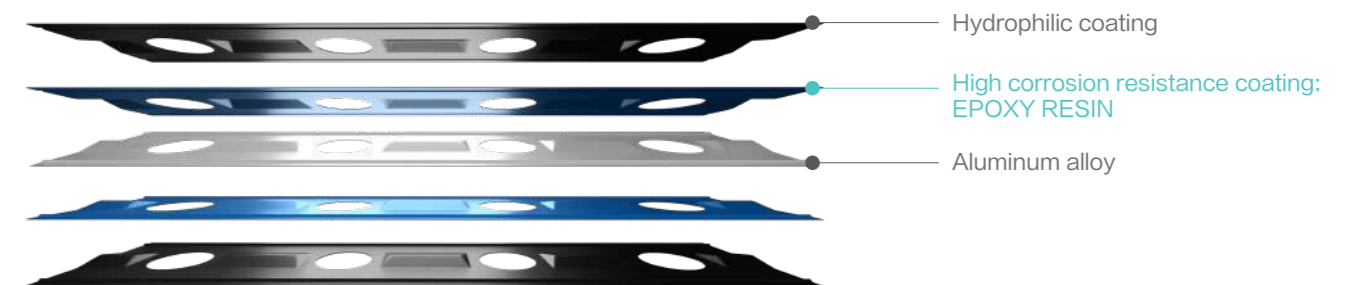

Dehumidification

Although all variables of the air cannot be controlled or affected completely, Hisense VRF can have a positive impact by regulating the temperature, humidity and moisture in the air. To choose humidity sensor installed in the IDU and match the appropriate controller, it is more comfortable to adjust humidity of room and achieve dehumidification function. The humidity sensor has more precise to control the humidity that can effectively inhibit the growth of bacteria and create a comfortable or healthy environment.

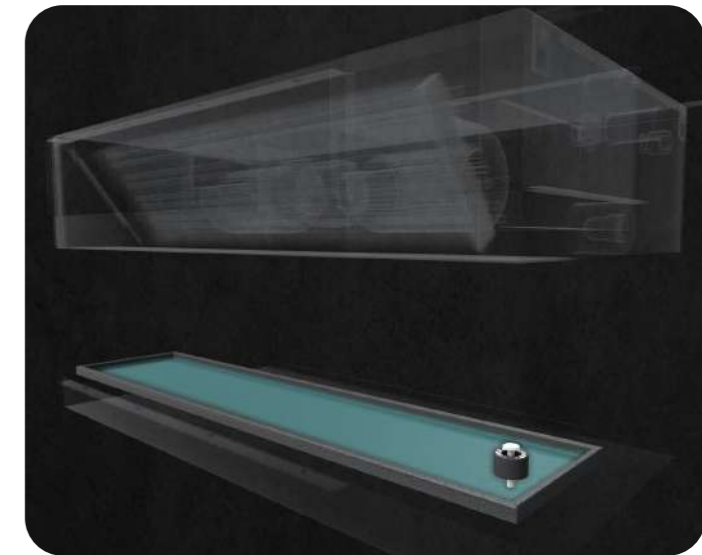
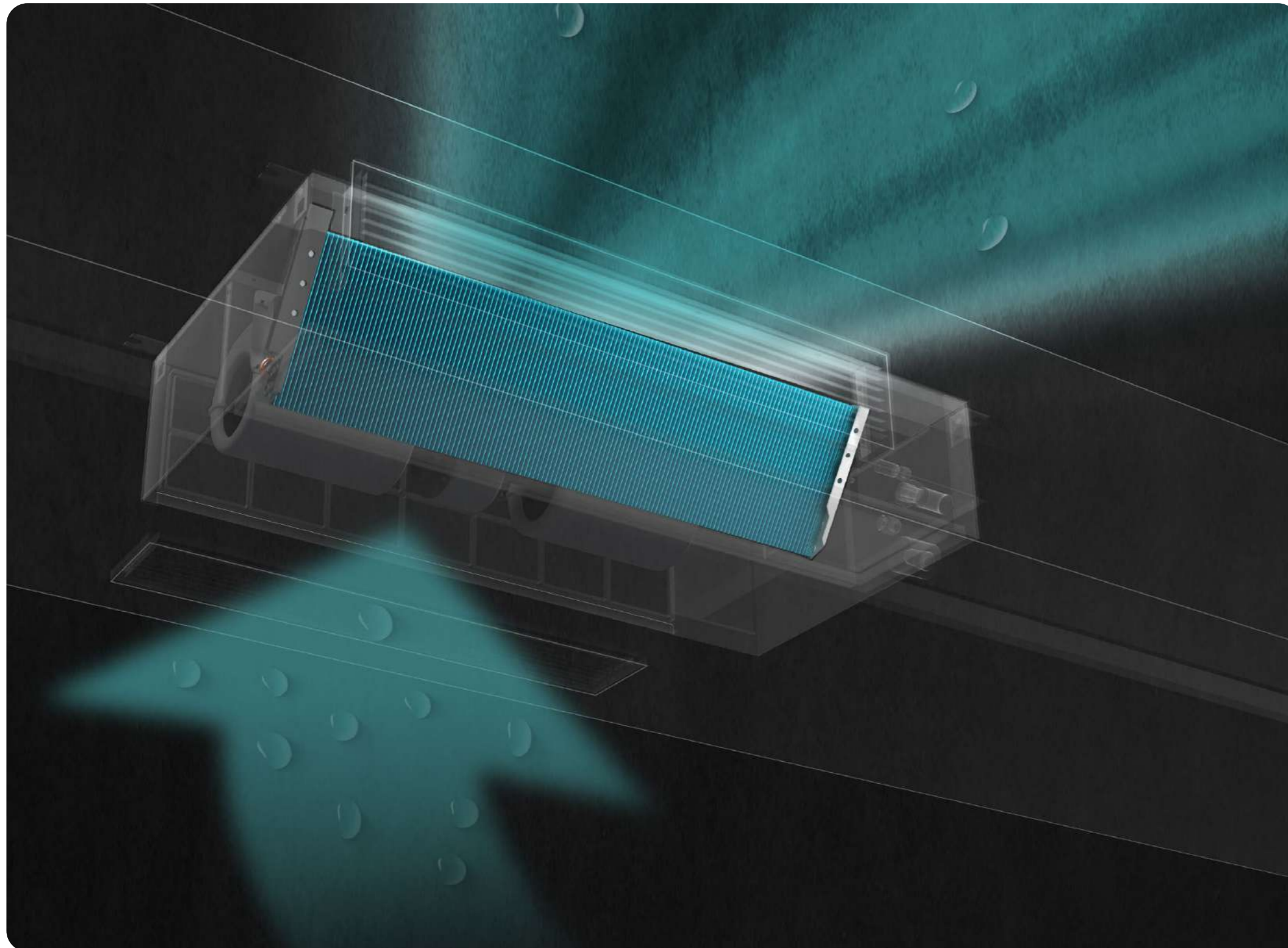

Float Switch

Besides providing reliable air-conditioning units, we also want to keep your possessions lasting. Hence, our indoor units have build-in water-leakage float switches. Alarming warnings will be displayed on controllers when condensate reaches a certain level, and would automatically turn-off itself when reaches a threatening level. Saving your ceilings and carpets from being soaked in times when drain pipes are clogged or drain pump breakdowns.

Hisense VRF Advantage

High Reliability

High Efficiency

Comfort

Convenience

Intelligence



High Reliability

Wide Operating Range

With a wide operating temperature range, the outdoor unit can run from -5°C to 55°C for cooling, which perfectly meets the customers' needs in different environments.

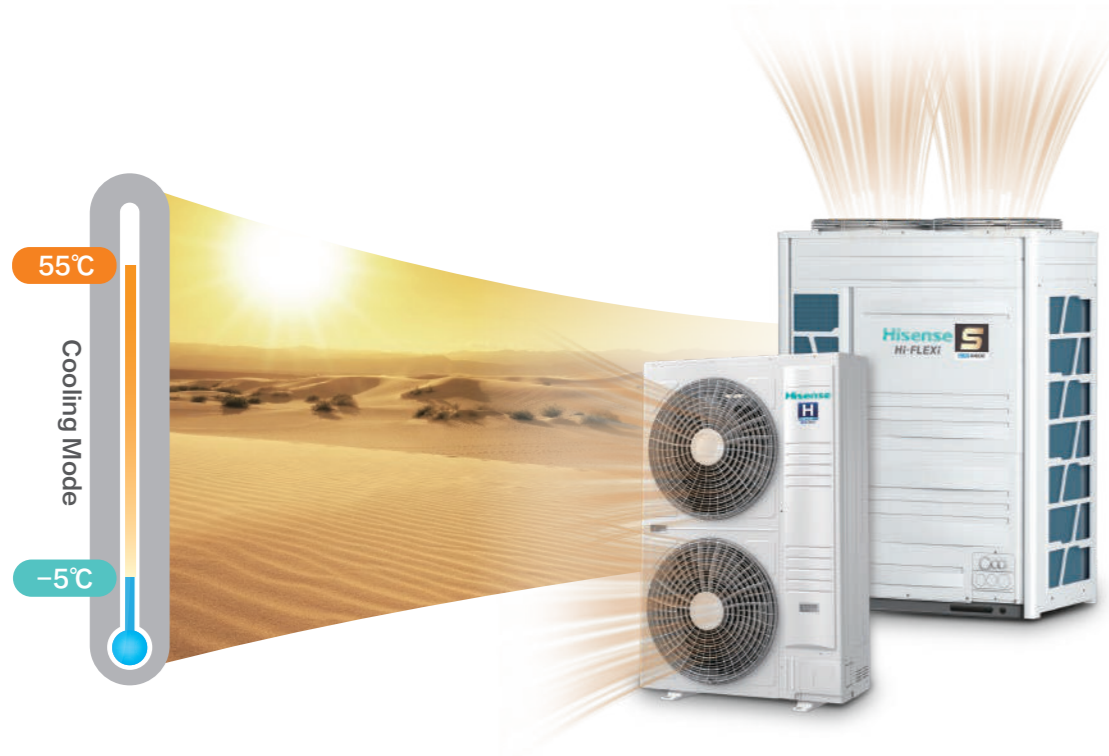

Reliable and Stable Electrical Box

Electrical box is designed with a unique labyrinth type, which can easily deal with rainstorms, typhoons and other severe weather. Even if there is heavy rainfall, it can be ensured no water inside, making electrical equipment safe secure and reliable.



Fan Backup Operation

Hi-FLEXi S+ Series High Ambient can achieve that in one double-fan module when one of the fan breakdown, it will not influence the other fan and the module can work normally. In the combined double-fan modules, when one of the fan breakdown the other modules will work normally.

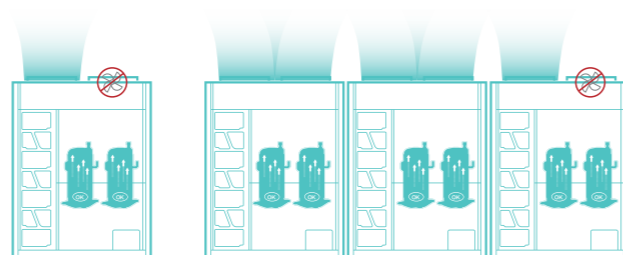

High Reliability

Rotation Technology

– Rotation technology --- compressor

Through the rotation technology, the running time of each outdoor unit is shared to ensure durability and extend life of each compressor.

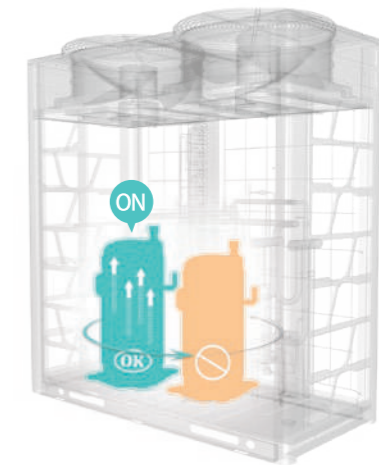

– Rotation technology --- module combination

To ensure the system reliability, the unit that runs less time will have priority to be used. It is very important to extend system life.

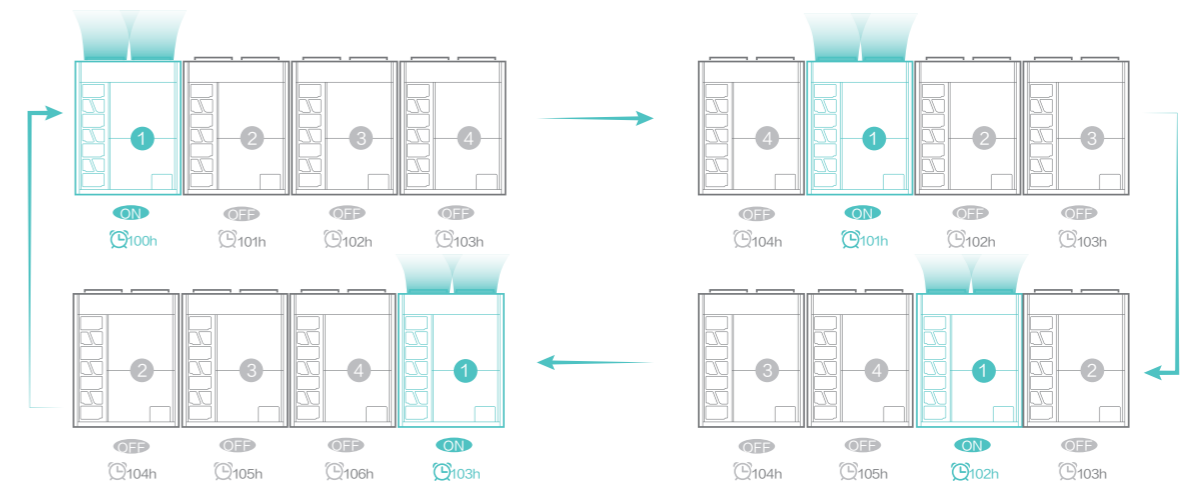

Dual Backup Operation

Hi-FLEXi S+ Series High Ambient has dual backup operation.

As for the first backup, if one of the two compressors in the outdoor unit fails (more than 18HP), the other compressor can run in emergency mode.

As for the second backup, if one module in a system fails then the alternative module can run in emergency mode.

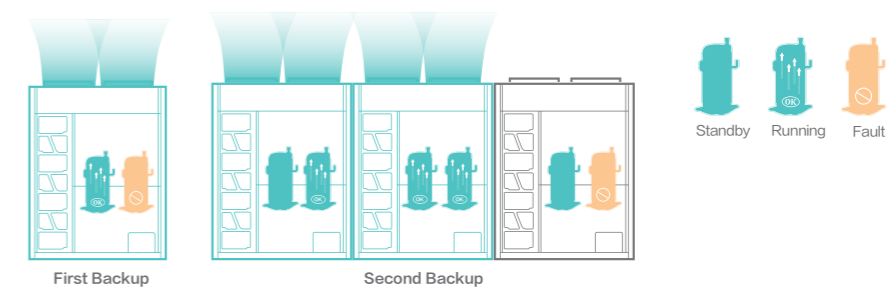

High Reliability

Oil Technology

– System oil cycle

The role of oil is extremely critical in maintaining the reliability and performance of compressor and hence the whole system. By recycling oil back into the compressor as much as possible, the lesser maintenance and servicing is needed.

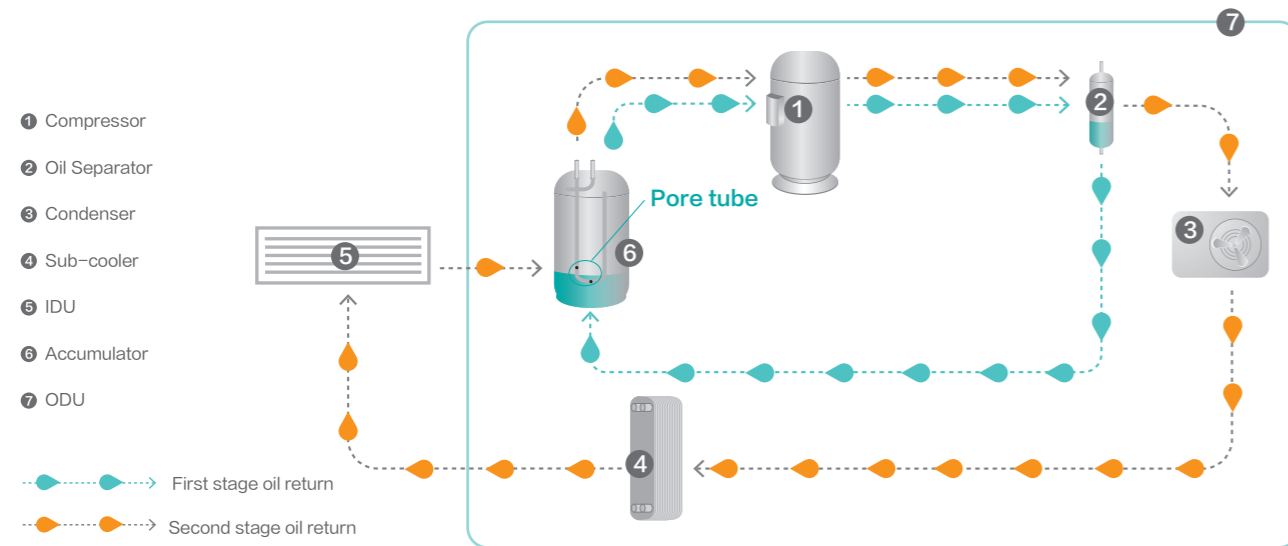

– Needless of oil balancing pipes

Hence oil balancing pipes creating extra cost and hassle during installation are unnecessary. Absence of oil balancing piping system, prevents system pressure and temperature fluctuations thus maintaining overall system's continuous stability.

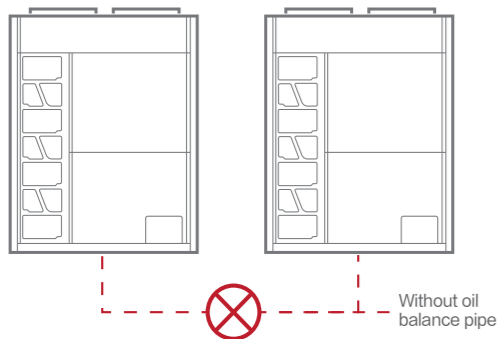

– Oil separation

First-stage oil separation is realized through efficient oil separation structure inside the compressor. Only a small amount of oil is brought out of the compressor. During second-stage oil separation, the small amount of oil discharged from compressor is separated by a large-capacity, high-efficiency centrifugal oil separator, with efficiency over 99%.

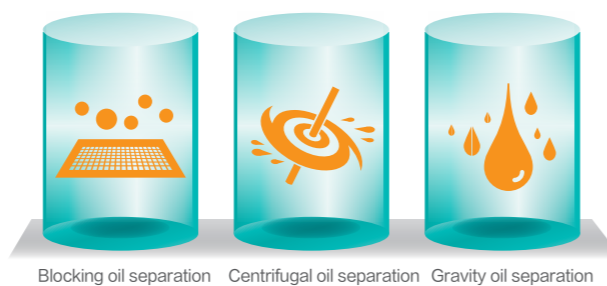

High Reliability

Self-protection

Taking a step further, Hisense VRF is capable of keeping themselves protected with algorithms embedded to make necessary protective decisions and measures based on different sensor readings & parameters. Including compressor protections, heat and temperature protections, over and under pressure protections and electricity protections.

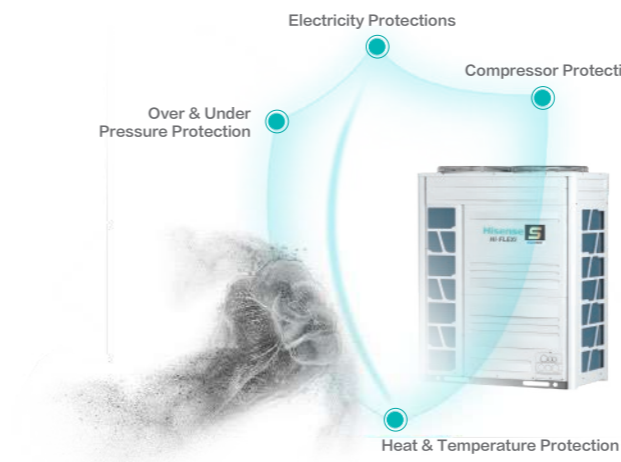

Electro-magnetic Protection

Air-conditioning units produced by Hisense VRF requires strict electromagnetic protection. As to overcome such inevitable natural phenomenon to cause damages, 4000V sudden high voltage tests are infused into the long list of electromagnetic quality tests in our internationally qualified test laboratories.



Reliability transportation

To make sure Hisense VRF units' capability to perform more than just coping to such conditions, strict laboratory assessments are required using simulators for the real shipping conditions of upto 6000 km and longer road and sea distance. Hence, tested to be capable to be shipping from China to Americas without damages, good as new.



High Efficiency

Optimized Refrigerant Circuit

As refrigerant flows in the system, energy will be lost due to friction and other factors naturally especially when refrigerant change phase, latent heat are lost when gas turns to liquid. Whereby, as more heat is dissipated out, higher the heat exchanger efficiency is. By making full use of heat dissipation, refrigerant flow layout is maneuvered into 2 to 1 Refrigerant Flow Path extends liquid refrigerant's occupancy and eventually the efficiency too.

2-to-1 Refrigerant flow path

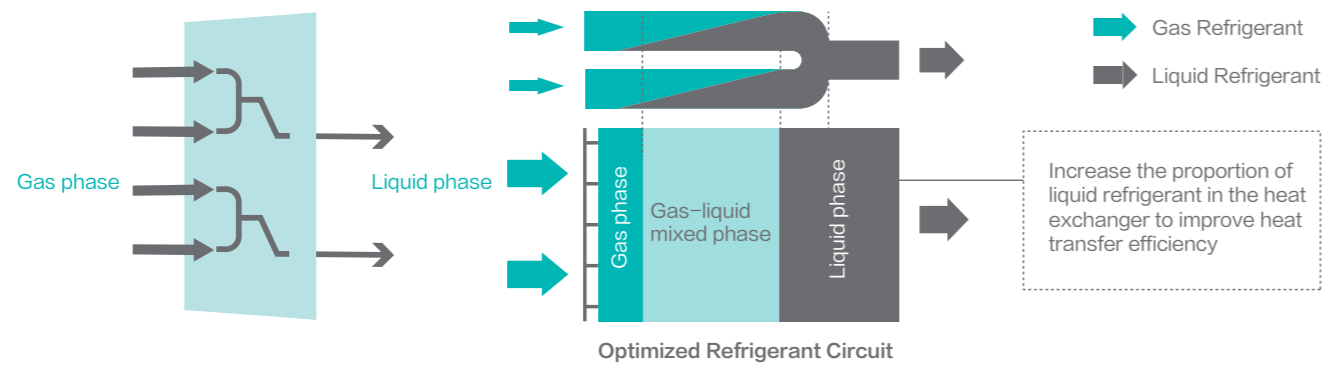

High Efficiency Aerodynamic Axial Fan

Fan blades are aerodynamically designed to reduce energy wastage in converting power consumed to unnecessary noise energy, reserving the energy to improve on flowrate performance and static pressure. Integration with brushless DC fan motor further improves the efficiency and noise of the propeller structure.

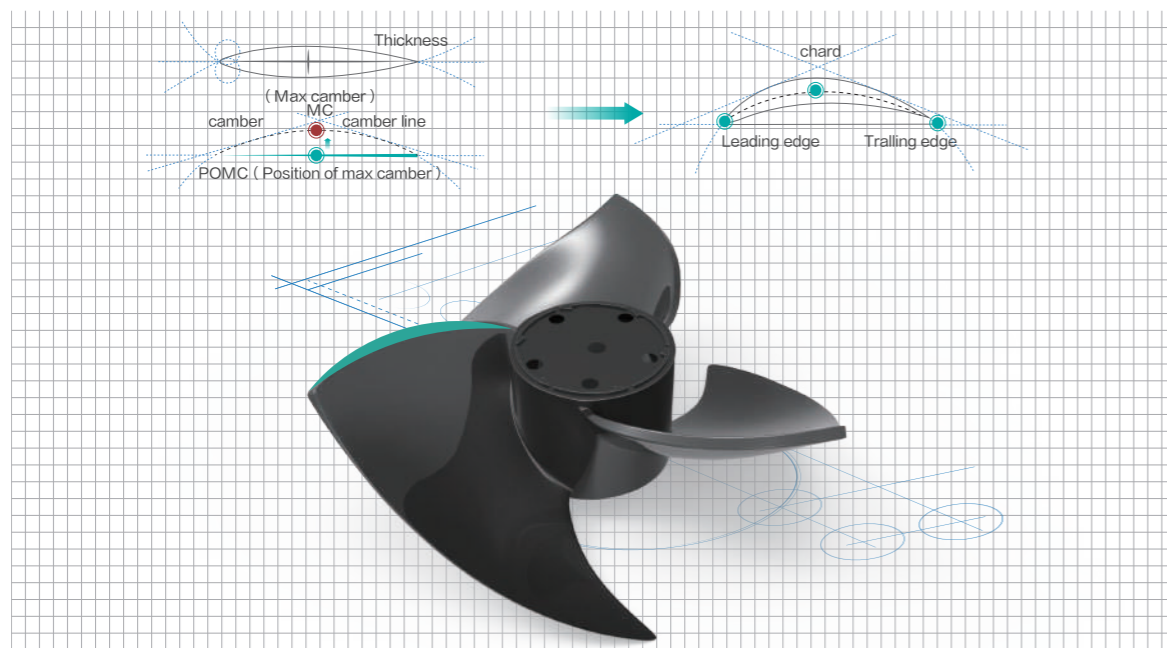

High Efficiency

High Efficiency Compressor

The scroll compressor has an excellent mechanism called as FCM (Frame Compliant Mechanism) which will perfectly increase the performance of the whole compressor. The heating performance will improve because there is storage heat inside the compressor's mass, example motor, compressor shell. The storage heat can be moved to condensing by reduce compressor's temperature or by lower superheat to optimum temperature. All of these increase the comprehensive competitiveness of the scroll compressor.

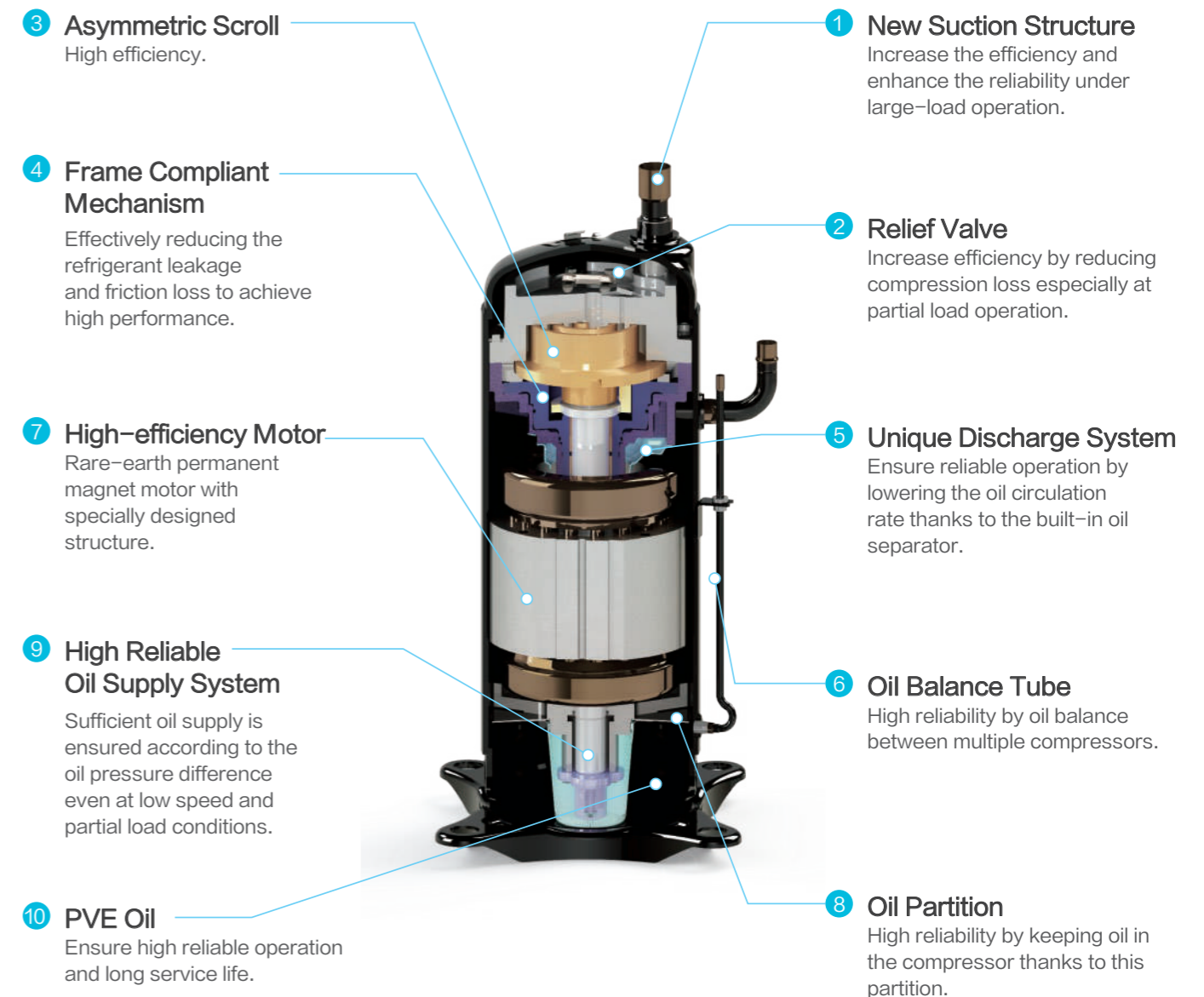

New Advanced Wavy Fin Design

A new commitment is made on new fin design to create better efficiency and more durable heat exchanger. With this new design, larger amount of fins can be allocated into the heat exchanger, increasing 22% heat exchange surface area.

As to improve heating capability, the new design fins are 40% more tolerant to frost, stretching out indoor heating time interval and further enhancing user's coziness. Heating time interval are tested to reach 50% increment compare to our previous models.

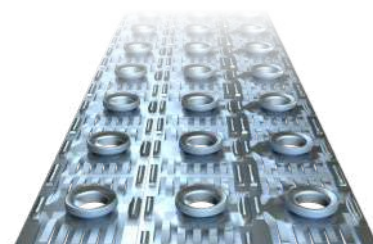

Stepped fins

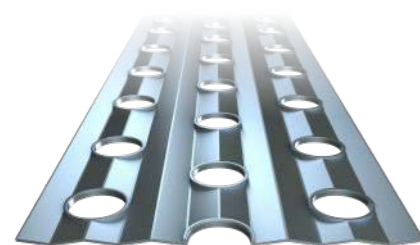

Latest wavy fins

Second-stage Sub-cooling Technology

The cooling section of the outdoor heat exchanger is uniquely designed to be more effective than the traditional outdoor units of the multi-split air conditioner without a sub-cooling design.

First-stage sub-cooling can reduce temperature by 12.5°C while second-stage sub-cooling can help achieve up to 27°C for efficient sub-cooling.

- Increasing cooling capacity of the unit refrigerant
- Reducing the resistance when refrigerant flowing in pipelines
- Increasing sub-cooling degree, more accurate controlling of electronic expansion valve, more stable operation
- Increasing sub-cooling degree, increasing the length of refrigerant pipe

Second-stage Sub-cooling Cycle Diagram

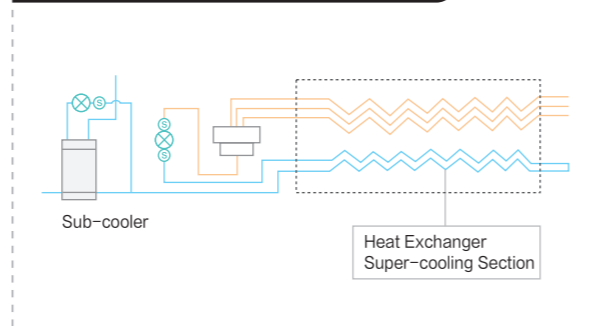

Second-stage Sub-cooling Pressure Enthalpy Diagram

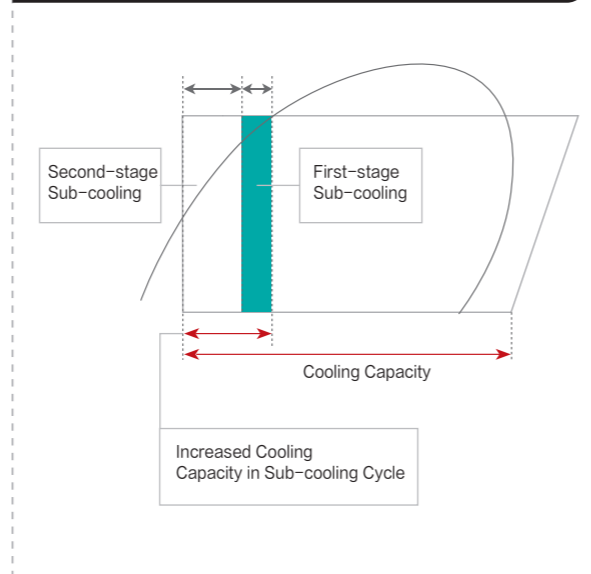

Features and Benefit		
Air Flow Resistance	Decreased 20%	↓
Total Heat Transfer Area	Improved 21.4%	↑
Heating Capacity Without Frost (Test Condition 7°C DB / 6°C WB)	Improved 1-3%	↑
Heating Capacity When Frosting (Test Condition 2°C DB / 1°C WB)	Improved 8-12%	↑
Ability to Resist Frost	Improved 40%	↑
Anti-corrosion Ability		↑

AirPure

Do you often bother with the poor air quality after staying for a long time in a confined room? Hisense VRF AirPure effectively purifies the air-conditioned space and keeps us safe and healthy.

All-in-one Purifying Ionizer

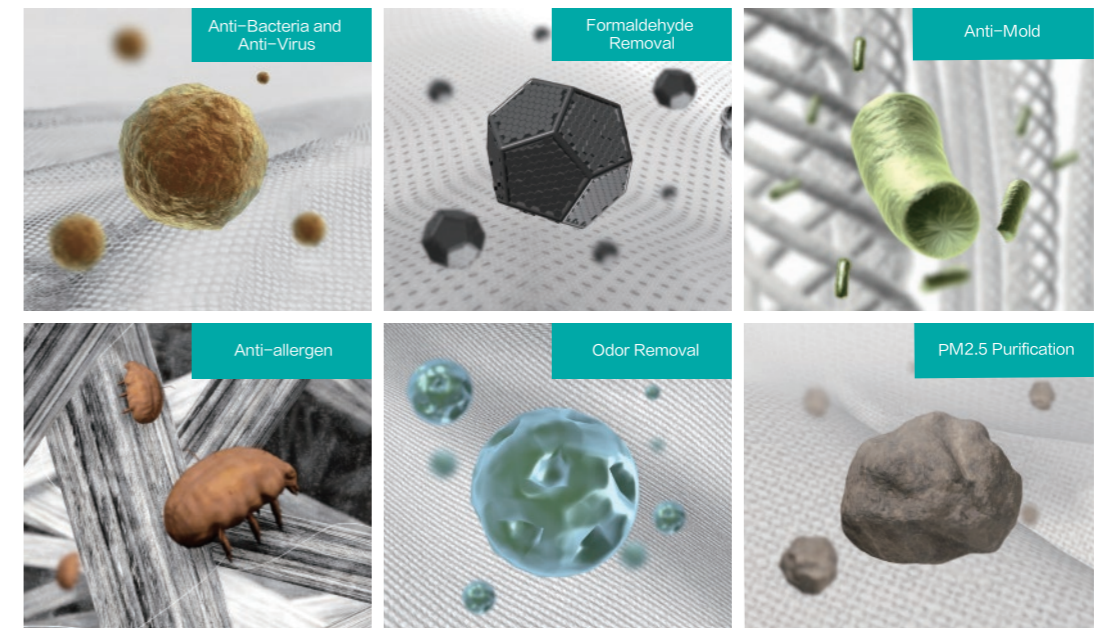

Hisense VRF indoor unit equipped with AirPure kit can release lots of negative ions, about 20 million pcs/cc.

These negative ions are carried throughout the room with air-conditioned air flow whereby obtaining air conditioning and air purification simultaneously. With the AirPure kit, the indoor unit has got the Tick Mark certification for air-conditioning sterilization products.

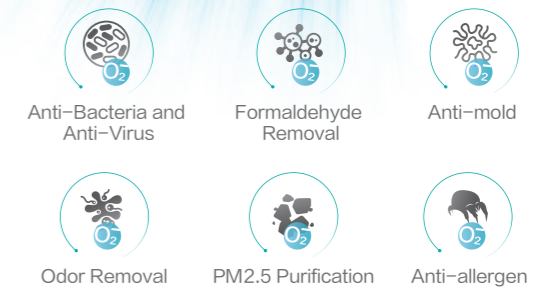
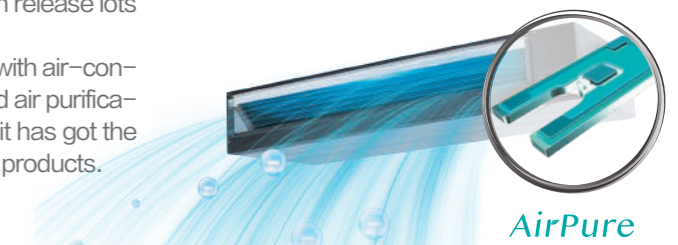

Note

4-way Cassette, Mini 4-way Cassette, Console, Ceiling Ducted and the new Wall Mounted which will be launched in the second half of 2021 can be equipped with the AirPure kit.

Hisense Refrigerant Temperature Setting

Features:

- 1) Evaporating temperature can be adjusted between 2°C to 16°C which is the widest on the market.
- 2) Rapidly cooling depends on the lower evaporating temperature.
- 3) Preventing cold draft bases on the higher evaporating temperatures.
- 4) Saving energy by increasing seasonal efficiency.

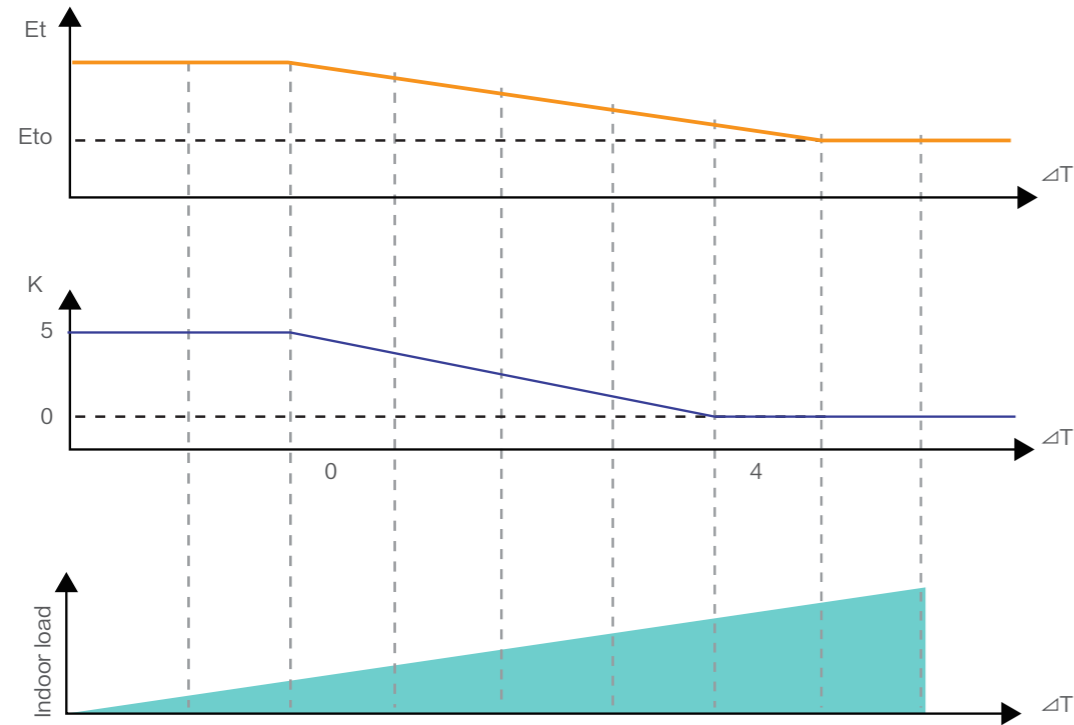

Refrigerant evaporation temperature : $E_t = E_{t0} + K$
 Evaporating temperature setting could be adjusted based on the difference between the indoor temperature (T_{in}) and the setting temperature (T_{set}).

$$\Delta T = T_{in} - T_{set}$$

E_t : evaporating temperature
 E_{t0} : initial value of evaporation temperature, E_{t0} can be adjusted through the outdoor unit setting.
 K can be automatically adjusted according to the difference between the indoor temperature and the setting temperature ΔT .

More Comfortable Air Distribution

User-friendly air supply mode and louvers control independently.

- a. The unit has the breeze mode that provides miniature draft through the holes at the four flat corners.
- b. The 4 air louvers can be controlled independently and 4 air speed adjustment are available to meet various requirement.

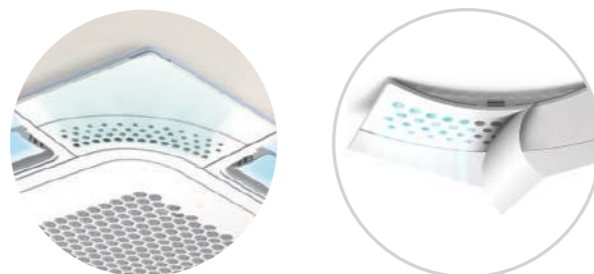

Automatically Control ON/OFF and Wind Direction

With motion sensor, the indoor unit will automatically adjust the setting temperature according to the indoor heat source load. The indoor unit will be turned off automatically when no people in room. The sensor also comes with draft functions to direct the air blowing people or avoiding people.

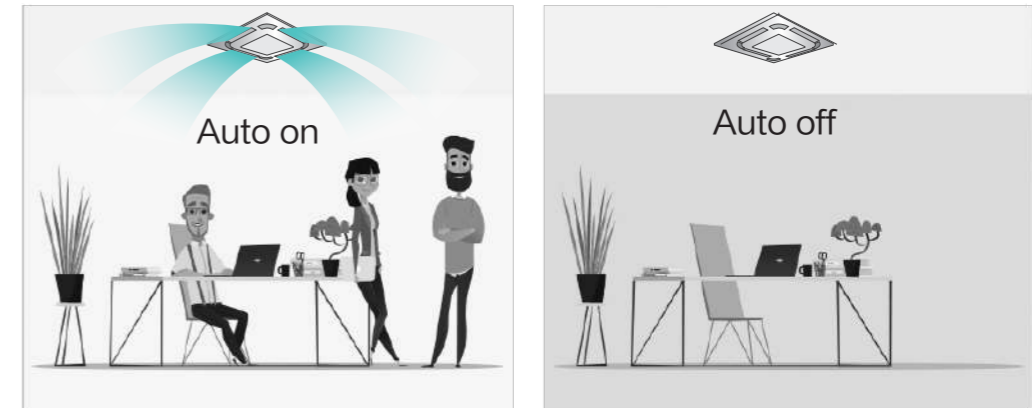

Precise Temperature Setting

Hisense VRF provides very close tolerance of temperature in the range of $\pm 0.5^\circ\text{C}$, reduces temperature fluctuation and effectively maintains the desired temperature.

Precisely judge indoor temperature:

- 1 Air return temperature sensor
- 2 Temperature sensor on wired remote controller
- 3 Based on the average value suitable for irregularly shaped rooms

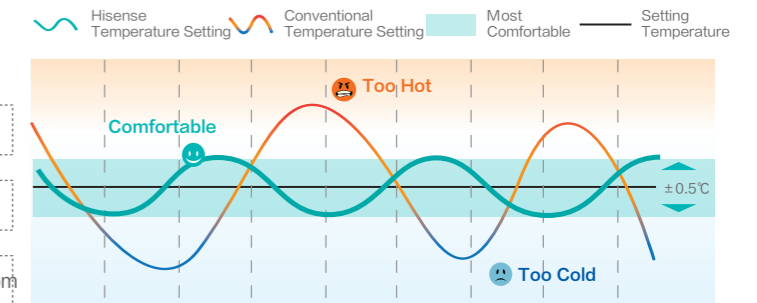

- Precisely judge

$\pm 0.5^\circ\text{C}$ tolerance is made true by high quality and high precision 2000 steps electronic expansion valve (EEV) used to control refrigerant flow more precisely depending on the real-time room temperature feedbacks from temperature sensors on controllers and indoor units.

2000-step electronic expansion valve to ensure precise flow adjustment based on the actual load of Indoor Unit.



2000-step Electronic Expansion Valve

Convenience

Top Class Low Noise Design

In accordance with application situation and structure, Hisense has been studying the technical and installation methods for noise reduction of indoor units from various aspects of fan motor, fan blade and air duct layout, which provides customers with the quietest air conditioned environment.

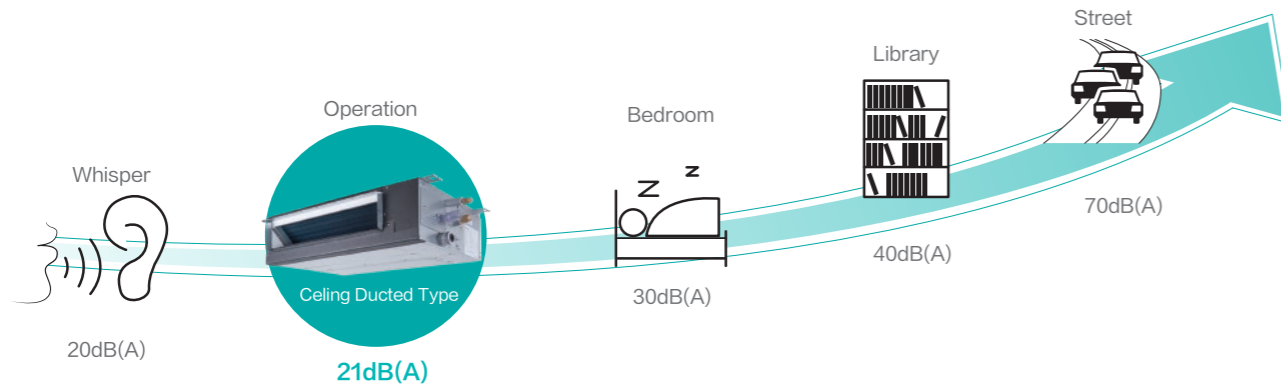

Automatic Restart

Hisense VRF is capable to restart automatically whenever there is an involuntary power supply shortage. Customers are free to choose from restoring to it to the state before power failure state or restarting the system completely. Such function comes in handy in equipment rooms whereby are constantly humanless, like server rooms.

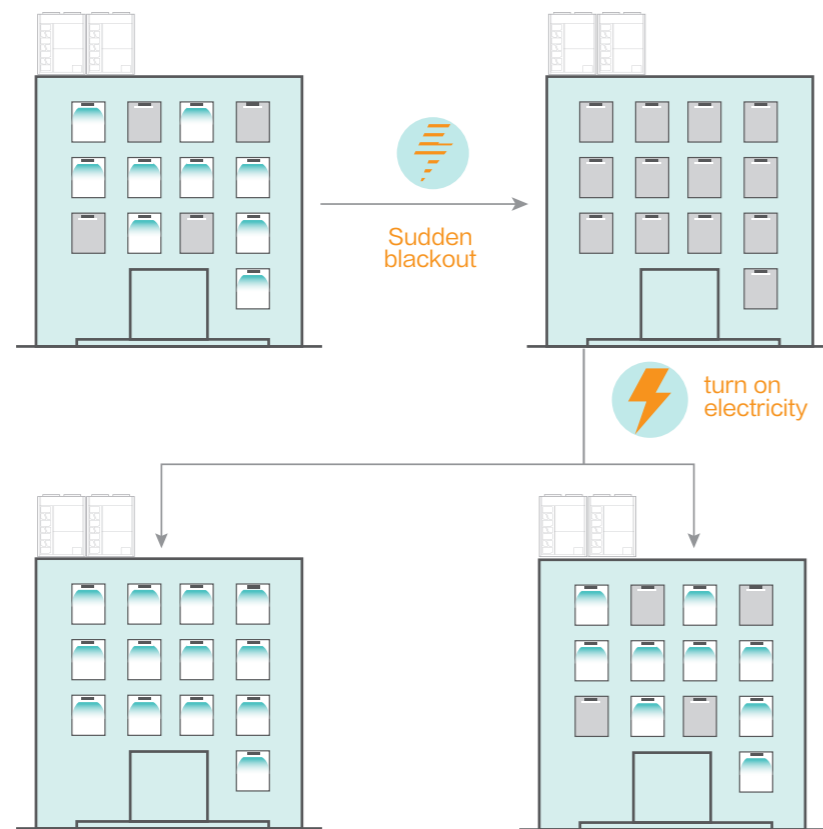

The ODU will re-start and return to default conditions.

The ODU will re-start and return to last conditions (keep memory).

Convenience

Night Mode

When outdoor conditions call for special low noise requirements, like in cases where outdoor units are installed in indoor equipment rooms with poor soundproof walls or continuous night operating conditions. Fear not, we've got you covered with our night mode to reduce sound pressure levels upto 30% routinely with flexible time intervals to meet different customer needs.

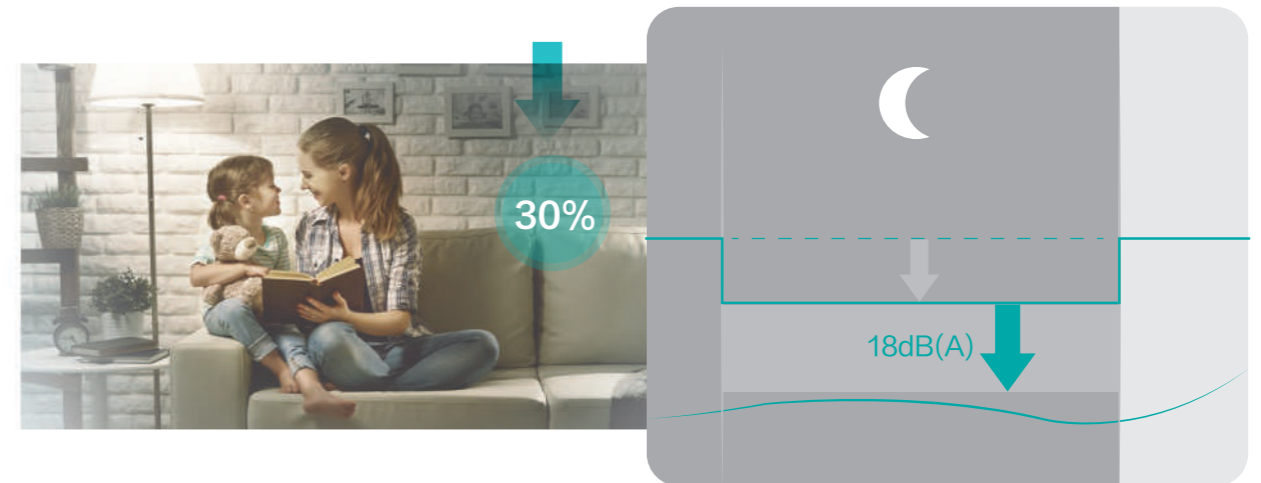

Fresh air duct adapter

New Hisense VRF indoor units are now infused with a fresh air duct opening for 10% free fresh air introductory directly from outdoor air, reducing the need of fresh air systems for medium to small spaces.

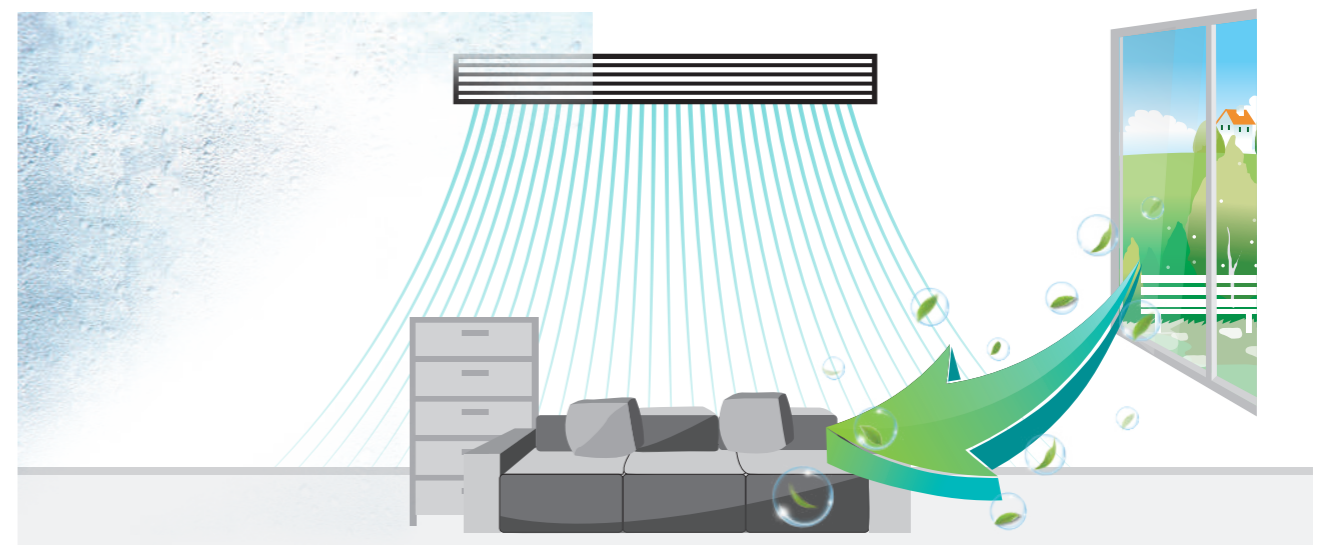

Convenience

Demand Mode

The intelligent demand mode can adjust the air conditioning automatically according to peak-valley requirements of electricity. It achieves balance between comfort and energy-saving while meeting the power demand for daily work.

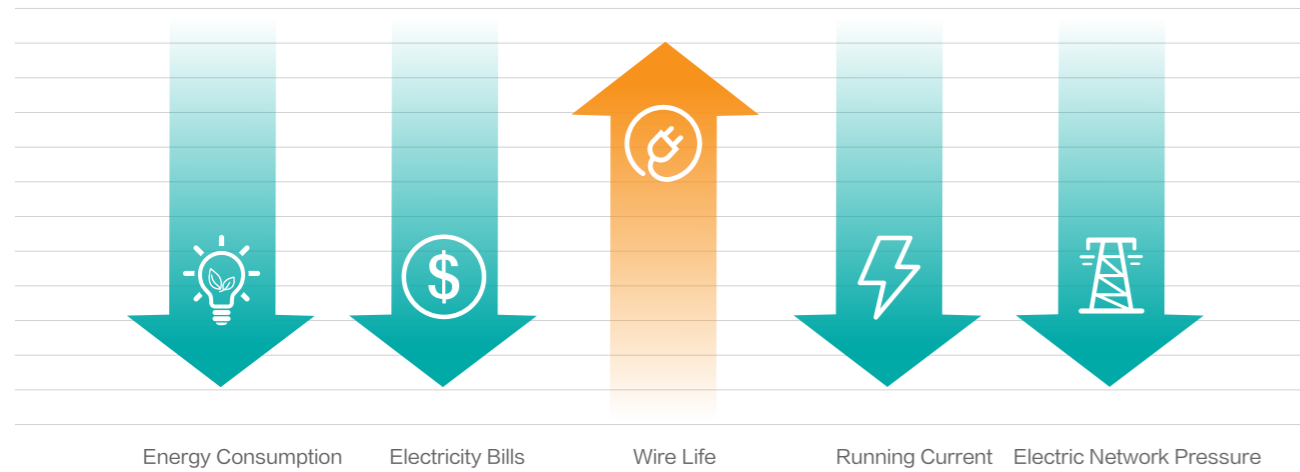

Intelligent Detection

The specially designed data collector can automatically detect the systems running condition. With real time monitoring, system parameters, trouble shooting, preventative maintenance can be managed.

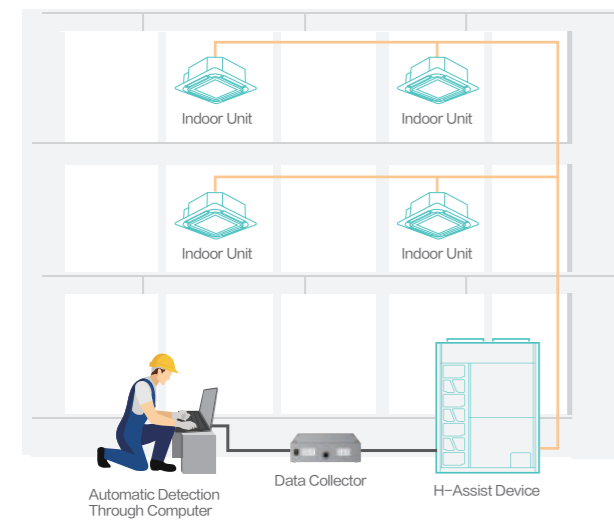

Independent Electrical and Mechanical Rooms

Hi-FLEXi S+ Series High Ambient divides the electrical and mechanical rooms. Also be same with two panels. Engineers are free to take the panels apart to check and maintain every details separately. All designs provide the convenience for installation and maintenance.

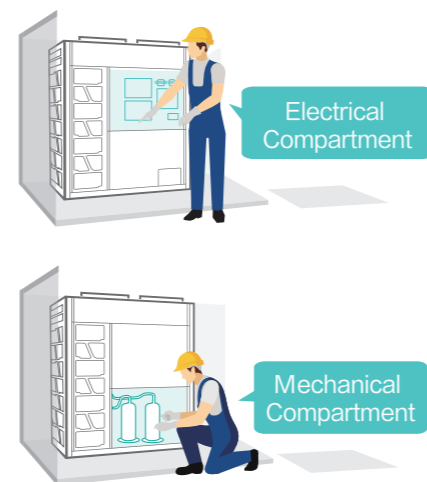

Convenience

Urgent Power-off Maintenance of IDUs

When one indoor unit need maintenance, it can be powered off separately. Also, it does not need any setting on outdoor, automatically re-registering all indoor unit and having no influence on the whole system.

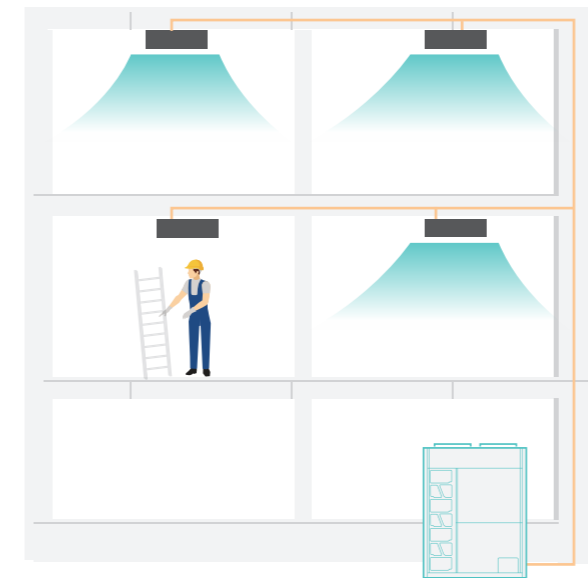

7-segment LED on the Outdoor

The 7-segment LED on the outdoor unit makes it easy to monitor and check the details about the operating status such as refrigerant temperature, pressure, compressor frequency, alarm code, etc., which makes both operation management and maintenance more convenient.

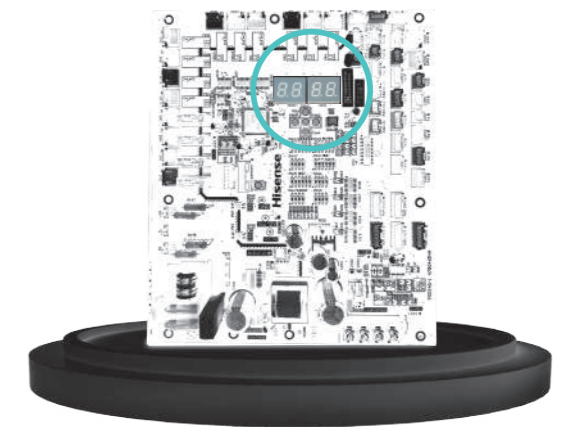

One-touch Test Run

Test runs are one of the essential part in testing & commissioning to make sure the HVAC system in a building works steadily and safely before hand over or soft openings. To make test run as simple as possible, Hisense VRF systems are capable to conduct test runs with just a button away wherever installers are, despite indoors or outdoors as one-touch test run functions are applicable in both outdoor and indoor units.

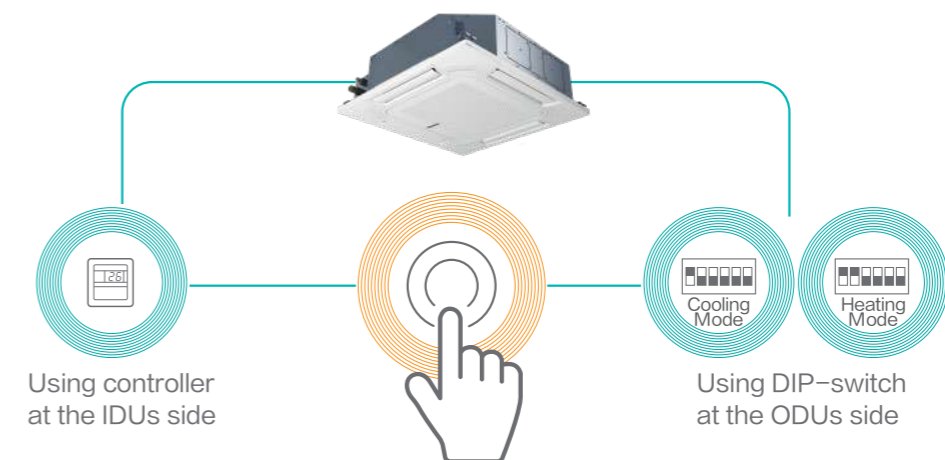

Convenience

Automatic Addressing

Imagine a large system with lots of indoor units, it could be tens or even hundreds as the number of system increases. The necessity to address each units could be so troublesome hence why not letting the software to auto address each indoor units by default. Such function is very important in troubleshooting and fault diagnosis when only specific indoor units malfunctioned. It is as easy as plug and play, connect the indoor units to the outdoor units and indoor unit addresses are completely set automatically.

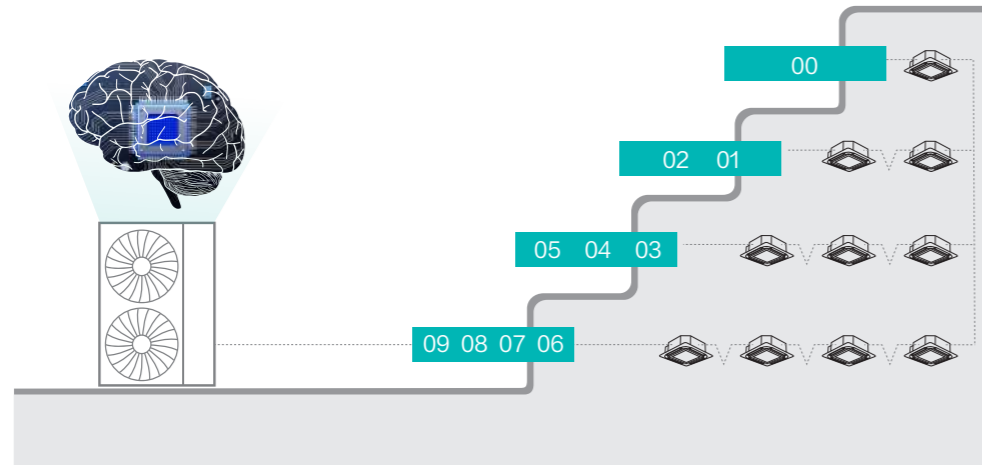

Note: only for 8-10HP

Compact Making Transportation and Installation Easier

Hi-FLEXi S+ Series High Ambient has the light weight and suitable size. It is easier to transport and install.

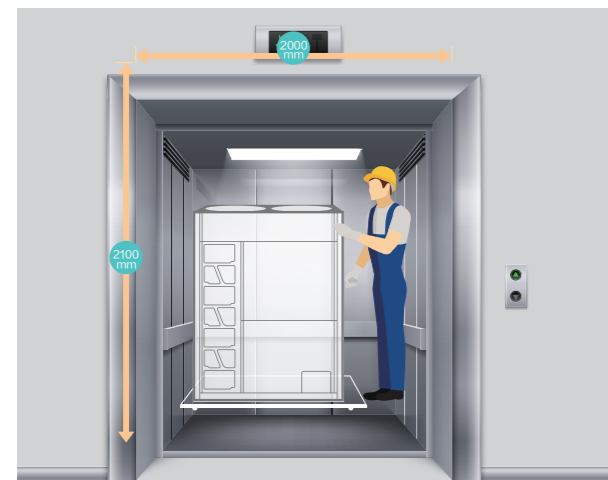

– Size suitable to be delivered by elevators

The largest size of module 28HP is only 1730mm × 1600mm × 750mm (H × W × D), which can be delivered through freight elevator, making transportation and installation easier.

Intelligent Matching IDUs

Match all kinds of hisense indoor units. If each air deflector can be controlled independently, the key will light. On the contrary, the key will dim and you can not click.



Connect with ceiling ducted type



Connect with 4-way cassette type

Intelligence

Indoor unit dry contact interface

In the indoor unit, ports are reserved for wider choice range of applications to turn the AC unit ON or OFF, like key-card power, window contact power and any other sensors or devices.

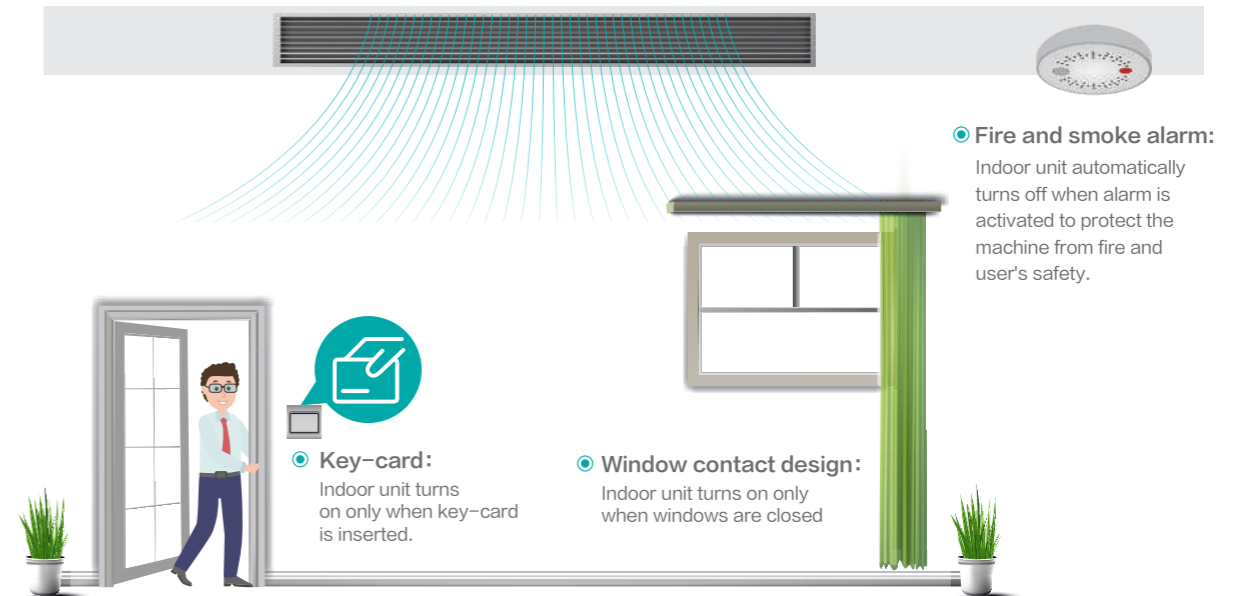

Note: this function can be achieved by the wired controller: HYPE-VA01A, HYXM-VB01A, HYPE-J01H.

Hi-Motion Intelligent Sensor

– Main Functions

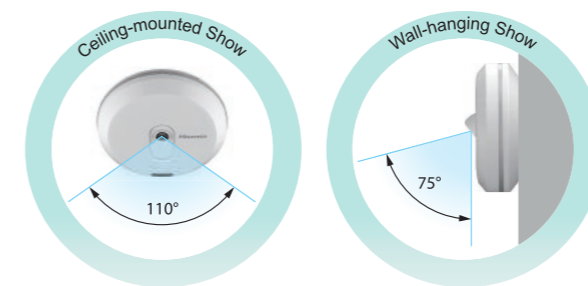

High Precision

Adjust AC temperature and air flow speed precisely according to the number of users

Wide Range

Sense as much as 34m² with almost no blind area

High Energy Conservation

Turn off AC automatically when nobody is in the room

Intelligent Control---Hi-Mit II

Users can control air-conditioning with phone APP. Different modes are chosen to meet the requirement. Do not worry data lost when APP is unloads. Hi-Mit II checks automatically and backups quickly the information.



Outdoor Unit

Hi-FLEXi S+ Series
High Ambient

Hi-Smart H Series
High Ambient



Hi-FLEXi S+ Series High Ambient

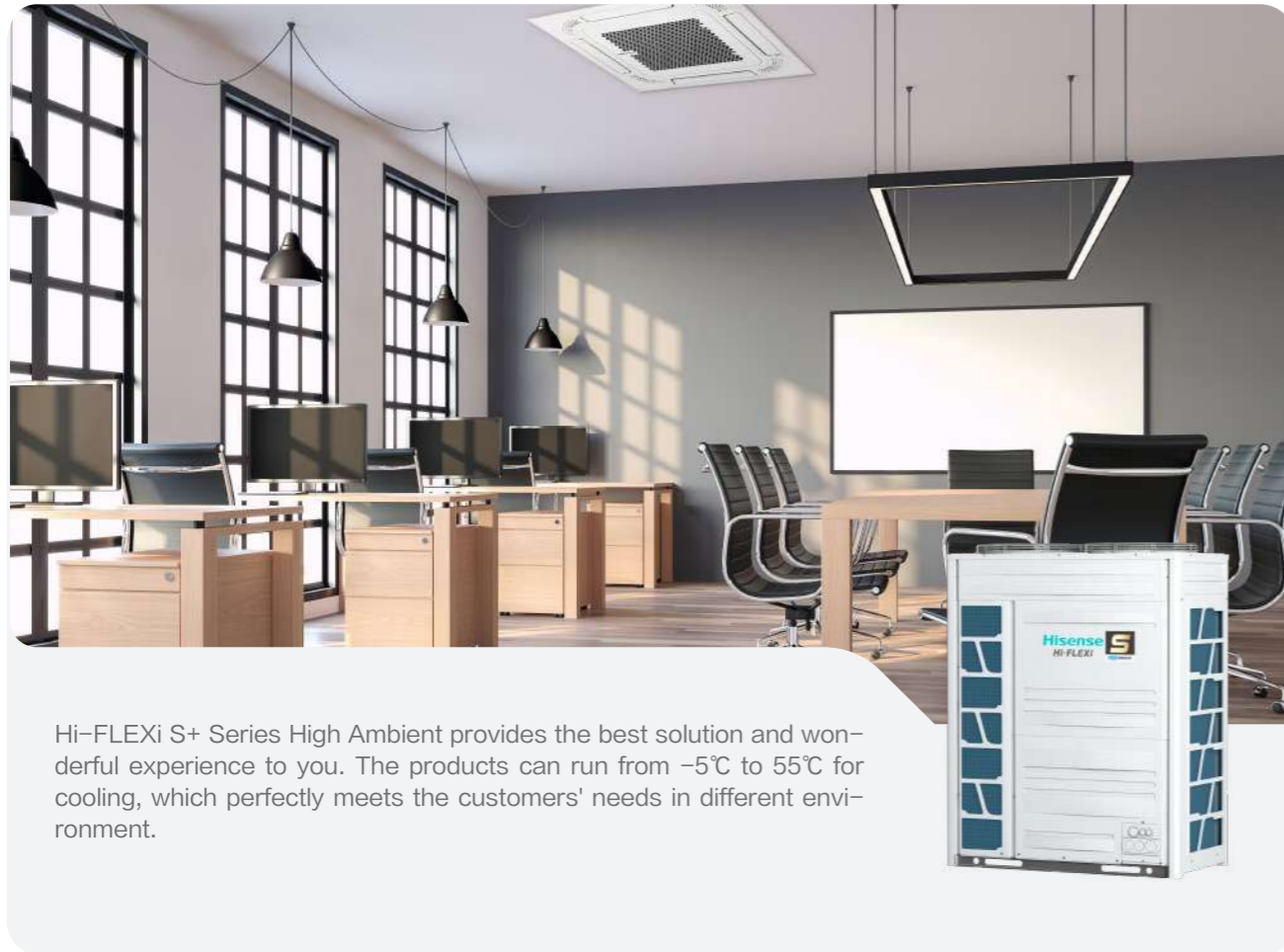

Hi-FLEXi S+ Series High Ambient provides the best solution and wonderful experience to you. The products can run from -5°C to 55°C for cooling, which perfectly meets the customers' needs in different environment.

Patented 360° Fitted Refrigerant Cooling Technology

To maintain the lifespan of the delicate electronics, Hi-FLEXi S+ Series High Ambient uses refrigerant cooling technology to effectively cool the whole electronic box. As such, it will overcome poor heat dissipation and high ambient temperature issues to maintain efficient operation even at harsh environment.

The refrigerant cooling unit adds the temperature sensor, which will be more precise to control the refrigerant cooling temperature and enhance the whole system reliability.

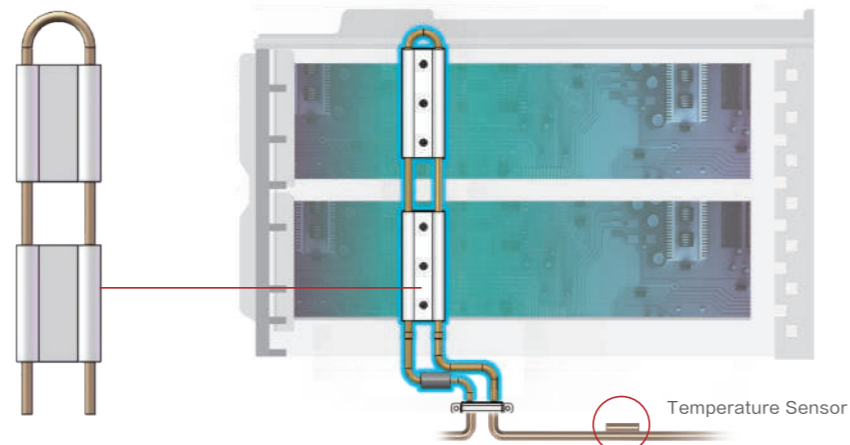

Hi-FLEXi S+ Series High Ambient

Extra Long Pipe Design

With extra long pipe, the height difference between the indoor unit and outdoor unit is up to 90m^* , which makes installation more flexible.

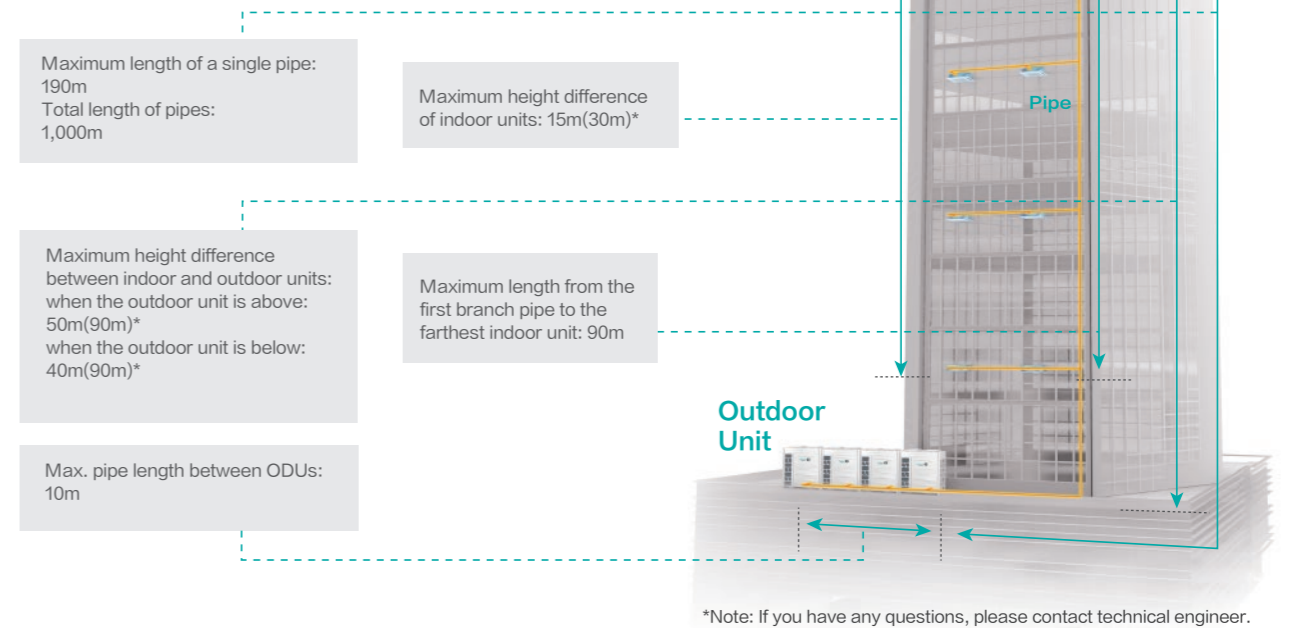

Fan Static Pressure Adaptive Technology

With static pressure adaptive technology, the fan of the outdoor unit can be adjusted in free static pressure based on system requirements to meet a variety of needs in different environments. The maximum external static pressure of the outdoor unit can be up to 110Pa^* , which provides better conditions for the layered installation and centralized installation. Higher static pressure and further distance of air supply of the outdoor unit ensure the smooth flow of air and solve condensing problems of the outdoor unit effectively.

*Note: For detailed information, please contact Hisense's technical staff.

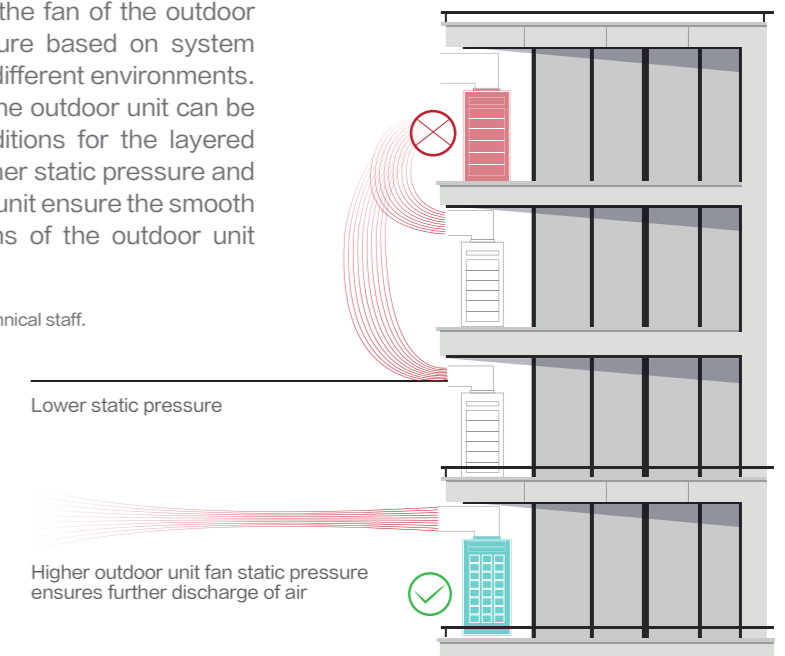

Hi-FLEXi S+ Series High Ambient



HP		8	10	12	14	16	18	
Model	Model	AVWT-76MHKFSE	AVWT-96MHKFSE	AVWT-114MHKFSE	AVWT-136MHKFSE	AVWT-154MHKFSE	AVWT-170MHKFSE	
	Modules	AVWT-76MHKFSE	AVWT-96MHKFSE	AVWT-114MHKFSE	AVWT-136MHKFSE	AVWT-154MHKFSE	AVWT-170MHKFSE	
		/	/	/	/	/	/	
		/	/	/	/	/	/	
Power Supply		AC 3Φ 380V~415V/50Hz/60Hz						
Cooling	Nominal Capacity T1 35°C	kW	22.4	28.0	33.5	40.0	45.0	50.0
		Btu/h	76000	96000	114000	136000	154000	170000
	Actual Capacity T3 46°C	kW	20.2	25.0	29.8	35.5	39.8	43.8
		Btu/h	69000	85000	102000	121000	136000	150000
	Power Consumption T1 35°C	kW	5.21	6.78	8.09	9.78	11.00	12.25
	Power Consumption T3 46°C	kW	6.43	8.11	9.63	11.67	13.40	14.85
EER T1 35°C	Btu/(W-h)	14.60	14.15	14.10	13.90	14.00	13.90	
EER T3 46°C	Btu/(W-h)	10.75	10.50	10.60	10.35	10.15	10.10	
Heating	Capacity	kW	25.0	31.5	37.5	45.0	50.0	56.0
		Btu/h	85000	107000	128000	154000	170000	192000
	Power Consumption	kW	5.77	7.59	9.21	11.72	13.70	16.97
	COP	kW/kW	4.33	4.15	4.07	3.84	3.65	3.30
Fan	Air Flow Rate	m³/min	183	183	183	200	200	200
	Fan Quantity		1	1	1	2	2	2
	Fan Style		DC Inverter					
	Static Pressure	Pa	110					
Sound	Sound Pressure Level ¹	dB(A)	59	61	61	62	62	63
Compressor	Type	-	Scroll Comp.					
	Compressor Quantity	PC	1	1	1	1	1	1
Refrigerant	Type	-	R410A					
	Pre-charged Quantity	kg	5.3	5.3	6.2	8.0	8.0	11.1
Weight	Net Weight	kg	218	220	222	270	271	293
	Gross Weight	kg	247	249	251	294	295	327
Dimensions	External (H×W×D)	mm	1730×950×750			1730×1210×750		
	Packing (H×W×D)	mm	1950×1015×790			1950×1275×790		
Ref. Piping	Gas	mm	φ19.05	φ22.20	φ25.40	φ25.40	φ28.60	φ28.60
	Liquid	mm	φ9.53	φ9.53	φ12.70	φ12.70	φ12.70	φ15.88
	Pressure (High/Low Pressure)	MPa	4.15/2.21	4.15/2.21	4.15/2.21	4.15/2.21	4.15/2.21	4.15/2.21
Connectable Indoor Units	Quantity	PC	13	16	19	23	26	29
Crankcase Heater Capacity	kW	0.08	0.08	0.08	0.08	0.08	0.08	
Refrigerant Flow Control		Micro-computer Control Expansion Valve						
Heat Exchanger Type		Multi-pass Cross-finned Tube						
Piping Design	Height Difference Between ODU and IDU	m(above)	50 (90m ²)					
		m(below)	40 (90m ²)					
	Height Difference Between IDUs	m	15 (30m ²)					
	Max. Piping Length	m	1000					
Operation Range	Cooling ³	°C DB	-5~55					
	Heating ³	°C WB	-25~16.5					

Notes: The above cooling and heating capacities show the capacities when the outdoor unit is operated with the 100% rating of indoor units, Cooling Operation Conditions (T1) Cooling Operation Conditions (T3) Heating Operation Conditions
 Indoor Air Inlet Temperature: 27°C DB / 19°C WB Indoor Air Inlet Temperature: 29°C DB / 19°C WB Indoor Air Inlet Temperature: 20°C DB / 15°C WB
 Outdoor Air Inlet Temperature: 35°C DB / 24°C WB Outdoor Air Inlet Temperature: 46°C DB / 24°C WB Outdoor Air Inlet Temperature: 7°C DB / 6°C WB
 Piping Length: 7.5 meters, Piping Lift: 0 meter
¹The above noise values are measured in the anechoic chamber without reflected echo, therefore the impact of the reflected echo must be included at the scene.
 Measurement point: 1 meter from the service cover surface and 1.5 meters from floor level.
²For detailed information, please contact Hisense's technical staff.
³Operation Control Range: 52°C~55°C / -25°C~-20°C.

Hi-FLEXi S+ Series High Ambient



HP		20	22	24	26	28	
Model	Model	AVWT-190MHKFSE	AVWT-212MHKFSE	AVWT-232MHKFSE	AVWT-250MHKFSE	AVWT-272MHKFSE	
	Modules	AVWT-190MHKFSE	AVWT-212MHKFSE	AVWT-232MHKFSE	AVWT-250MHKFSE	AVWT-272MHKFSE	
		/	/	/	/	/	
		/	/	/	/	/	
Power Supply		AC 3Φ 380V~415V/50Hz/60Hz					
Cooling	Nominal Capacity T1 35°C	kW	56.0	61.5	68.0	72.5	80.0
		Btu/h	192000	210000	232000	248000	272000
	Actual Capacity T3 46°C	kW	49.6	54.0	58.0	63.5	68.0
		Btu/h	170000	184000	198000	216000	232000
	Power Consumption T1 35°C	kW	13.49	14.89	16.50	18.90	21.00
	Power Consumption T3 46°C	kW	17.06	19.09	21.02	22.10	24.36
EER T1 35°C	Btu/(W-h)	14.25	14.10	14.05	13.10	12.95	
EER T3 46°C	Btu/(W-h)	9.95	9.65	9.40	9.75	9.50	
Heating	Capacity	kW	63.0	69.0	75.0	80.0	90.0
		Btu/h	214000	236000	256000	272000	308000
	Power Consumption	kW	19.87	22.48	24.59	26.85	31.58
	COP	kW/kW	3.17	3.07	3.05	2.98	2.85
Fan	Air Flow Rate	m³/min	267	296	296	350	350
	Fan Quantity		2	2	2	2	2
	Fan Style		DC Inverter				
	Static Pressure	Pa	110				
Sound	Sound Pressure Level ¹	dB(A)	63	64	65	66	67
Compressor	Type	-	Scroll Comp.				
	Compressor Quantity	PC	2	2	2	2	2
Refrigerant	Type	-	R410A				
	Pre-charged Quantity	kg	11.8	12.7	12.7	13.5	13.5
Weight	Net Weight	kg	363	364	365	389	390
	Gross Weight	kg	401	402	403	433	434
Dimensions	External (H×W×D)	mm	1730×1350×750			1730×1600×750	
	Packing (H×W×D)	mm	1950×1420×790			1950×1665×790	
Ref. Piping	Gas	mm	φ28.60	φ28.60	φ28.60	φ31.75	φ31.75
	Liquid	mm	φ15.88	φ15.88	φ15.88	φ19.05	φ19.05
	Pressure (High/Low Pressure)	MPa	4.15/2.21	4.15/2.21	4.15/2.21	4.15/2.21	4.15/2.21
Connectable Indoor Units	Quantity	PC	33	36	40	43	47
Crankcase Heater Capacity	kW	0.16	0.16	0.16	0.16	0.16	
Refrigerant Flow Control		Micro-computer Control Expansion Valve					
Heat Exchanger Type		Multi-pass Cross-finned Tube					
Piping Design	Height Difference Between ODU and IDU	m(above)	50 (90m ²)				
		m(below)	40 (90m ²)				
	Height Difference Between IDUs	m	15 (30m ²)				
	Max. Piping Length	m	1000				
Operation Range	Cooling ³	°C DB	-5~55				
	Heating ³	°C WB	-25~16.5				

Hi-FLEXi S+ Series High Ambient



HP		16		18		20		22	
Model	Model	AVWT-152MHKFSE	AVWT-172MHKFSE	AVWT-192MHKFSE	AVWT-210MHKFSE				
	Modules	AVWT-76MHKFSE	AVWT-76MHKFSE	AVWT-96MHKFSE	AVWT-96MHKFSE				
		AVWT-76MHKFSE	AVWT-96MHKFSE	AVWT-96MHKFSE	AVWT-114MHKFSE				
		/	/	/	/				
Power Supply		AC 3Φ 380V-415V/50Hz/60Hz							
Cooling	Nominal Capacity T1 35°C	kW	44.8	50.4	56.0	61.5			
		Btu/h	152000	172000	192000	210000			
	Actual Capacity T3 46°C	kW	40.4	45.2	50.0	54.8			
		Btu/h	138000	154000	170000	186000			
	Power Consumption T1 35°C	kW	10.42	11.99	13.56	14.87			
	Power Consumption T3 46°C	kW	12.86	14.54	16.22	17.74			
EER T1 35°C	Btu/(W-h)	14.60	14.35	14.15	14.10				
	EER T3 46°C	Btu/(W-h)	10.75	10.60	10.50	10.50			
Heating	Capacity	kW	50.0	56.5	63.0	69.0			
		Btu/h	170000	192000	214000	236000			
	Power Consumption	kW	11.54	13.36	15.18	16.80			
COP	kW/kW	4.33	4.23	4.15	4.11				
	Air Flow Rate	m³/min	366	366	366	366			
Fan	Fan Quantity		1+1	1+1	1+1	1+1			
	Fan Style		DC Inverter						
	Static Pressure	Pa	110						
Sound	Sound Pressure Level ¹	dB(A)	62	63	64	64			
		Type	Scroll Comp.						
Compressor	Compressor Quantity	PC	1+1	1+1	1+1	1+1			
		Type	R410A						
Refrigerant	Pre-charged Quantity	kg	5.3+5.3	5.3+5.3	5.3+5.3	5.3+6.2			
		Net Weight	kg	218+218	218+220	220+220	220+222		
Weight	Gross Weight	kg	247+247	247+249	249+249	249+251			
		External (H×W×D)	mm	1730×(950+950)×750					
Dimensions	Packing (H×W×D)	mm	1950×(1015+1015)×790						
		Gas	mm	φ28.60	φ28.60	φ28.60	φ28.60		
Ref. Piping	Liquid	mm	φ12.70	φ15.88	φ15.88	φ15.88			
		Pressure (High/Low Pressure)	MPa	4.15/2.21	4.15/2.21	4.15/2.21	4.15/2.21		
	Connectable Indoor Units	Quantity	PC	26	29	33	36		
Crankcase Heater Capacity	kW	0.16	0.16	0.16	0.16				
Refrigerant Flow Control	Micro-computer Control Expansion Valve								
Heat Exchanger Type	Multi-pass Cross-finned Tube								
Piping Design	Height Difference Between ODU and IDU	m(above)	50 (90m ²)						
		m(below)	40 (90m ²)						
	Height Difference Between IDUs	m	15 (30m ²)						
Max. Piping Length	m	1000							
Operation Range	Cooling ³	°C DB	-5-55						
	Heating ³	°C WB	-25-16.5						

Notes: The above cooling and heating capacities show the capacities when the outdoor unit is operated with the 100% rating of indoor units, Cooling Operation Conditions (T1) Cooling Operation Conditions (T3) Heating Operation Conditions
 Indoor Air Inlet Temperature: 27°C DB / 19°C WB Indoor Air Inlet Temperature: 29°C DB / 19°C WB Indoor Air Inlet Temperature: 20°C DB / 15°C WB
 Outdoor Air Inlet Temperature: 35°C DB / 24°C WB Outdoor Air Inlet Temperature: 46°C DB / 24°C WB Outdoor Air Inlet Temperature: 7°C DB / 6°C WB
 Piping Length: 7.5 meters, Piping Lift: 0 meter
¹The above noise values are measured in the anechoic chamber without reflected echo, therefore the impact of the reflected echo must be included at the scene.
 Measurement point: 1 meter from the service cover surface and 1.5 meters from floor level.
²For detailed information, please contact Hisense's technical staff.
³Operation Control Range: 52°C-55°C / -25°C--20°C.

Hi-FLEXi S+ Series High Ambient



HP		24		26		28		30	
Model	Model	AVWT-228MHKFSE	AVWT-250MHKFSE	AVWT-272MHKFSE	AVWT-290MHKFSE				
	Modules	AVWT-114MHKFSE	AVWT-114MHKFSE	AVWT-136MHKFSE	AVWT-136MHKFSE				
		AVWT-114MHKFSE	AVWT-136MHKFSE	AVWT-136MHKFSE	AVWT-154MHKFSE				
		/	/	/	/				
Power Supply		AC 3Φ 380V-415V/50Hz/60Hz							
Cooling	Nominal Capacity T1 35°C	kW	67.0	73.5	80.0	85.0			
		Btu/h	228000	250000	272000	290000			
	Actual Capacity T3 46°C	kW	59.6	65.3	71.0	75.3			
		Btu/h	204000	222000	242000	256000			
	Power Consumption T1 35°C	kW	16.18	17.87	19.56	20.78			
	Power Consumption T3 46°C	kW	19.26	21.30	23.34	25.07			
EER T1 35°C	Btu/(W-h)	14.10	14.00	13.90	13.95				
	EER T3 46°C	Btu/(W-h)	10.60	10.40	10.35	10.20			
Heating	Capacity	kW	75.0	82.5	90.0	95.0			
		Btu/h	256000	282000	308000	324000			
	Power Consumption	kW	18.42	20.93	23.44	25.42			
COP	kW/kW	4.07	3.94	3.84	3.74				
	Air Flow Rate	m³/min	366	383	400	400			
Fan	Fan Quantity		1+1	1+2	2+2	2+2			
	Fan Style		DC Inverter						
	Static Pressure	Pa	110						
Sound	Sound Pressure Level ¹	dB(A)	64	65	65	65			
		Type	Scroll Comp.						
Compressor	Compressor Quantity	PC	1+1	1+1	1+1	1+1			
		Type	R410A						
Refrigerant	Pre-charged Quantity	kg	6.2+6.2	6.2+8	8+8	8+8			
		Net Weight	kg	222+222	222+270	270+270	270+271		
Weight	Gross Weight	kg	251+251	251+294	294+294	294+295			
		External (H×W×D)	mm	1730×(950+950)×750	1730×(950+1210)×750	1730×(1210+1210)×750			
Dimensions	Packing (H×W×D)	mm	1950×(1015+1015)×790	1950×(1015+1275)×790	1950×(1275+1275)×790				
		Gas	mm	φ28.60	φ31.75	φ31.75	φ31.75		
Ref. Piping	Liquid	mm	φ15.88	φ19.05	φ19.05	φ19.05			
		Pressure (High/Low Pressure)	MPa	4.15/2.21	4.15/2.21	4.15/2.21	4.15/2.21		
	Connectable Indoor Units	Quantity	PC	40	43	47	49		
Crankcase Heater Capacity	kW	0.16	0.16	0.16	0.16				
Refrigerant Flow Control	Micro-computer Control Expansion Valve								
Heat Exchanger Type	Multi-pass Cross-finned Tube								
Piping Design	Height Difference Between ODU and IDU	m(above)	50 (90m ²)						
		m(below)	40 (90m ²)						
	Height Difference Between IDUs	m	15 (30m ²)						
Max. Piping Length	m	1000							
Operation Range	Cooling ³	°C DB	-5-55						
	Heating ³	°C WB	-25-16.5						

Hi-FLEXi S+ Series High Ambient



HP		32	34	36	38	
Model	Model	AVWT-308MHKFSE	AVWT-324MHKFSE	AVWT-340MHKFSE	AVWT-360MHKFSE	
	Modules	AVWT-154MHKFSE	AVWT-154MHKFSE	AVWT-170MHKFSE	AVWT-170MHKFSE	
		AVWT-154MHKFSE	AVWT-170MHKFSE	AVWT-170MHKFSE	AVWT-190MHKFSE	
		/	/	/	/	
Power Supply		AC 3φ 380V~415V/50Hz/60Hz				
Cooling	Nominal Capacity T1 35°C	kW	90.0	95.0	100.0	106.0
		Btu/h	308000	324000	342000	362000
	Actual Capacity T3 46°C	kW	79.6	83.6	87.6	93.4
		Btu/h	272000	286000	298000	318000
	Power Consumption T1 35°C	kW	22.00	23.25	24.50	25.74
	Power Consumption T3 46°C	kW	26.80	28.25	29.70	31.91
EER T1 35°C	Btu/(W-h)	14.00	13.95	13.95	14.05	
EER T3 46°C	Btu/(W-h)	10.15	10.10	10.05	9.95	
Heating	Capacity	kW	100.0	106.0	112.0	119.0
		Btu/h	342000	362000	382000	405000
	Power Consumption	kW	27.40	30.67	33.94	36.84
COP	kW/kW	3.65	3.46	3.30	3.23	
Fan	Air Flow Rate	m³/min	400	400	400	467
	Fan Quantity		2+2	2+2	2+2	2+2
	Fan Style		DC Inverter			
Sound	Sound Pressure Level ¹	Pa	110			
		dB(A)	65	66	66	66
Compressor	Type	-	Scroll Comp.			
	Compressor Quantity	PC	1+1	1+1	1+1	1+2
Refrigerant	Type	-	R410A			
	Pre-charged Quantity	kg	8+8	8+11.1	11.1+11.1	11.1+11.8
Weight	Net Weight	kg	271+271	271+293	293+293	293+363
	Gross Weight	kg	295+295	295+327	327+327	327+401
Dimensions	External (H×W×D)	mm	1730×(1210+1210)×750			1730×(1210+1350)×750
	Packing (H×W×D)	mm	1950×(1275+1275)×790			1950×(1275+1420)×790
Ref. Piping	Gas	mm	φ31.75	φ38.1	φ38.1	φ38.1
	Liquid	mm	φ19.05	φ19.05	φ19.05	φ19.05
	Pressure (High/Low Pressure)	MPa	4.15/2.21	4.15/2.21	4.15/2.21	4.15/2.21
Connectable Indoor Units	Quantity	PC	52	55	59	62
Crankcase Heater Capacity	kW		0.16	0.16	0.16	0.24
Refrigerant Flow Control			Micro-computer Control Expansion Valve			
Heat Exchanger Type			Multi-pass Cross-finned Tube			
Piping Design	Height Difference Between ODU and IDU	m(above)	50 (90m ²)			
		m(below)	40 (90m ²)			
	Height Difference Between IDUs	m	15 (30m ²)			
Max. Piping Length	m	1000				
Operation Range	Cooling ³	°C DB	-5~55			
	Heating ³	°C WB	-25~16.5			

Notes: The above cooling and heating capacities show the capacities when the outdoor unit is operated with the 100% rating of indoor units, Cooling Operation Conditions (T1) Cooling Operation Conditions (T3) Heating Operation Conditions
 Indoor Air Inlet Temperature: 27°C DB / 19°C WB Indoor Air Inlet Temperature: 29°C DB / 19°C WB Indoor Air Inlet Temperature: 20°C DB / 15°C WB
 Outdoor Air Inlet Temperature: 35°C DB / 24°C WB Outdoor Air Inlet Temperature: 46°C DB / 24°C WB Outdoor Air Inlet Temperature: 7°C DB / 6°C WB
 Piping Length: 7.5 meters, Piping Lift: 0 meter
¹The above noise values are measured in the anechoic chamber without reflected echo, therefore the impact of the reflected echo must be included at the scene.
 Measurement point: 1 meter from the service cover surface and 1.5 meters from floor level.
²For detailed information, please contact Hisense's technical staff.
³Operation Control Range: 52°C~55°C / -25°C~-20°C.

Hi-FLEXi S+ Series High Ambient



HP		40	42	44	46	48	
Model	Model	AVWT-382MHKFSE	AVWT-402MHKFSE	AVWT-422MHKFSE	AVWT-444MHKFSE	AVWT-464MHKFSE	
	Modules	AVWT-170MHKFSE	AVWT-170MHKFSE	AVWT-190MHKFSE	AVWT-212MHKFSE	AVWT-232MHKFSE	
		AVWT-212MHKFSE	AVWT-232MHKFSE	AVWT-232MHKFSE	AVWT-232MHKFSE	AVWT-232MHKFSE	
		/	/	/	/	/	
Power Supply		AC 3φ 380V~415V/50Hz/60Hz					
Cooling	Nominal Capacity T1 35°C	kW	111.5	118.0	124.0	129.5	136.0
		Btu/h	380000	405000	425000	440000	465000
	Actual Capacity T3 46°C	kW	97.8	101.8	107.6	112.0	116.0
		Btu/h	334000	348000	368000	382000	396000
	Power Consumption T1 35°C	kW	27.14	28.75	29.99	31.39	33.00
	Power Consumption T3 46°C	kW	33.94	35.87	38.08	40.11	42.04
EER T1 35°C	Btu/(W-h)	14.00	14.10	14.15	14.00	14.10	
EER T3 46°C	Btu/(W-h)	9.85	9.70	9.65	9.50	9.40	
Heating	Capacity	kW	125.0	131.0	138.0	144.0	150.0
		Btu/h	425000	445000	470000	490000	510000
	Power Consumption	kW	39.45	41.56	44.46	47.07	49.18
COP	kW/kW	3.17	3.15	3.10	3.06	3.05	
Fan	Air Flow Rate	m³/min	496	496	563	592	592
	Fan Quantity		2+2	2+2	2+2	2+2	2+2
	Fan Style		DC Inverter				
Sound	Sound Pressure Level ¹	Pa	110				
		dB(A)	67	67	67	68	68
Compressor	Type	-	Scroll Comp.				
	Compressor Quantity	PC	1+2	1+2	2+2	2+2	2+2
Refrigerant	Type	-	R410A				
	Pre-charged Quantity	kg	11.1+12.7	11.1+12.7	11.8+12.7	12.7+12.7	12.7+12.7
Weight	Net Weight	kg	293+364	293+365	363+365	364+365	365+365
	Gross Weight	kg	327+402	327+403	401+403	402+403	403+403
Dimensions	External (H×W×D)	mm	1730×(1210+1350)×750			1730×(1350+1350)×750	
	Packing (H×W×D)	mm	1950×(1275+1420)×790			1950×(1420+1420)×790	
Ref. Piping	Gas	mm	φ38.1	φ38.1	φ38.1	φ41.3	φ41.3
	Liquid	mm	φ19.05	φ19.05	φ19.05	φ22.2	φ22.2
	Pressure (High/Low Pressure)	MPa	4.15/2.21	4.15/2.21	4.15/2.21	4.15/2.21	4.15/2.21
Connectable Indoor Units	Quantity	PC	64	64	64	64	64
Crankcase Heater Capacity	kW		0.24	0.24	0.32	0.32	0.32
Refrigerant Flow Control			Micro-computer Control Expansion Valve				
Heat Exchanger Type			Multi-pass Cross-finned Tube				
Piping Design	Height Difference Between ODU and IDU	m(above)	50 (90m ²)				
		m(below)	40 (90m ²)				
	Height Difference Between IDUs	m	15 (30m ²)				
Max. Piping Length	m	1000					
Operation Range	Cooling ³	°C DB	-5~55				
	Heating ³	°C WB	-25~16.5				

Hi-FLEXi S+ Series High Ambient



HP		50		52		54		56	
Model	Model	AVWT-482MHKFSE	AVWT-504MHKFSE	AVWT-522MHKFSE	AVWT-544MHKFSE				
	Modules	AVWT-232MHKFSE	AVWT-232MHKFSE	AVWT-250MHKFSE	AVWT-272MHKFSE				
		AVWT-250MHKFSE	AVWT-272MHKFSE	AVWT-272MHKFSE	AVWT-272MHKFSE				
		/	/	/	/				
Power Supply		AC 3 ϕ 380V-415V/50Hz/60Hz							
Cooling	Nominal Capacity T1 35°C	kW	140.5	148.0	152.5	160.0			
		Btu/h	480000	505000	520000	545000			
	Actual Capacity T3 46°C	kW	121.5	126.0	131.5	136.0			
		Btu/h	415000	430000	450000	465000			
	Power Consumption T1 35°C	kW	35.40	37.50	39.90	42.00			
	Power Consumption T3 46°C	kW	43.12	45.38	46.46	48.72			
EER	EER T1 35°C	Btu/(W-h)	13.55	13.45	13.05	13.00			
	EER T3 46°C	Btu/(W-h)	9.60	9.50	9.70	9.55			
Heating	Capacity	kW	155.0	165.0	170.0	180.0			
		Btu/h	530000	565000	580000	615000			
	Power Consumption	kW	51.44	56.17	58.43	63.16			
COP	COP	kW/kW	3.01	2.94	2.91	2.85			
	Air Flow Rate	m ³ /min	646	646	700	700			
Fan	Fan Quantity		2+2	2+2	2+2	2+2			
	Fan Style		DC Inverter						
	Static Pressure	Pa	110						
Sound	Sound Pressure Level ¹	dB(A)	69	69	70	70			
		Type	Scroll Comp.						
Compressor	Compressor Quantity	PC	2+2	2+2	2+2	2+2			
		Type	R410A						
Refrigerant	Pre-charged Quantity	kg	12.7+13.5	12.7+13.5	13.5+13.5	13.5+13.5			
		Net Weight	kg	365+389	365+390	389+390	390+390		
Weight	Gross Weight	kg	403+433	403+434	433+434	434+434			
		External (H×W×D)	mm	1730×(1350+1600)×750			1730×(1600+1600)×750		
Dimensions	Packing (H×W×D)	mm	1950×(1420+1665)×790			1950×(1665+1665)×790			
		Gas	mm	φ41.3	φ41.3	φ41.3	φ41.3		
Ref. Piping	Liquid	mm	φ22.2	φ22.2	φ22.2	φ22.2			
		Pressure (High/Low Pressure)	MPa	4.15/2.21	4.15/2.21	4.15/2.21	4.15/2.21		
		Connectable Indoor Units	Quantity	PC	64	64	64	64	
Crankcase Heater Capacity	kW	0.32	0.32	0.32	0.32				
Refrigerant Flow Control	Micro-computer Control Expansion Valve								
Heat Exchanger Type	Multi-pass Cross-finned Tube								
Piping Design	Height Difference Between ODU and IDU	m(above)	50 (90m ²)						
		m(below)	40 (90m ²)						
	Height Difference Between IDUs	m	15 (30m ²)						
Max. Piping Length	m	1000							
Operation Range	Cooling ³	°C DB	-5~55						
	Heating ³	°C WB	-25~-16.5						

Notes: The above cooling and heating capacities show the capacities when the outdoor unit is operated with the 100% rating of indoor units, Cooling Operation Conditions (T1) Cooling Operation Conditions (T3) Heating Operation Conditions
 Indoor Air Inlet Temperature: 27°C DB / 19°C WB Indoor Air Inlet Temperature: 29°C DB / 19°C WB Indoor Air Inlet Temperature: 20°C DB / 15°C WB
 Outdoor Air Inlet Temperature: 35°C DB / 24°C WB Outdoor Air Inlet Temperature: 46°C DB / 24°C WB Outdoor Air Inlet Temperature: 7°C DB / 6°C WB
 Piping Length: 7.5 meters, Piping Lift: 0 meter
¹The above noise values are measured in the anechoic chamber without reflected echo, therefore the impact of the reflected echo must be included at the scene.
 Measurement point: 1 meter from the service cover surface and 1.5 meters from floor level.
²For detailed information, please contact Hisense's technical staff.
³Operation Control Range: 52°C-55°C / -25°C--20°C.

Hi-FLEXi S+ Series High Ambient



HP		58		60		62		64	
Model	Model	AVWT-552MHKFSE	AVWT-572MHKFSE	AVWT-592MHKFSE	AVWT-614MHKFSE				
	Modules	AVWT-170MHKFSE	AVWT-170MHKFSE	AVWT-170MHKFSE	AVWT-170MHKFSE				
		AVWT-170MHKFSE	AVWT-170MHKFSE	AVWT-190MHKFSE	AVWT-212MHKFSE				
		AVWT-212MHKFSE	AVWT-232MHKFSE	AVWT-232MHKFSE	AVWT-232MHKFSE				
Power Supply		AC 3 ϕ 380V-415V/50Hz/60Hz							
Cooling	Nominal Capacity T1 35°C	kW	161.5	168.0	174.0	179.5			
		Btu/h	550000	575000	595000	610000			
	Actual Capacity T3 46°C	kW	141.6	145.6	151.4	155.8			
		Btu/h	485000	495000	515000	530000			
	Power Consumption T1 35°C	kW	39.39	41.00	42.24	43.64			
	Power Consumption T3 46°C	kW	48.79	50.72	52.93	54.96			
EER	EER T1 35°C	Btu/(W-h)	13.95	14.00	14.10	14.00			
	EER T3 46°C	Btu/(W-h)	9.95	9.75	9.75	9.65			
Heating	Capacity	kW	181.0	187.0	194.0	200.0			
		Btu/h	620000	640000	660000	680000			
	Power Consumption	kW	56.42	58.53	61.43	64.04			
COP	COP	kW/kW	3.21	3.19	3.16	3.12			
	Air Flow Rate	m ³ /min	696	696	763	792			
Fan	Fan Quantity		2+2+2	2+2+2	2+2+2	2+2+2			
	Fan Style		DC Inverter						
	Static Pressure	Pa	110						
Sound	Sound Pressure Level ¹	dB(A)	68	69	69	69			
		Type	Scroll Comp.						
Compressor	Compressor Quantity	PC	1+1+2	1+1+2	1+2+2	1+2+2			
		Type	R410A						
Refrigerant	Pre-charged Quantity	kg	11.1+11.1+12.7	11.1+11.1+12.7	11.1+11.8+12.7	11.1+12.7+12.7			
		Net Weight	kg	293+293+364	293+293+365	293+363+365	293+364+365		
Weight	Gross Weight	kg	327+327+402	327+327+403	327+401+403	327+402+403			
		External (H×W×D)	mm	1730×(1210+1210+1350)×750			1730×(1210+1350+1350)×750		
Dimensions	Packing (H×W×D)	mm	1950×(1275+1275+1420)×790			1950×(1275+1420+1420)×790			
		Gas	mm	φ44.5	φ44.5	φ44.5	φ44.5		
Ref. Piping	Liquid	mm	φ22.2	φ22.2	φ22.2	φ22.2			
		Pressure (High/Low Pressure)	MPa	4.15/2.21	4.15/2.21	4.15/2.21	4.15/2.21		
		Connectable Indoor Units	Quantity	PC	64	64	64	64	
Crankcase Heater Capacity	kW	0.32	0.32	0.40	0.40				
Refrigerant Flow Control	Micro-computer Control Expansion Valve								
Heat Exchanger Type	Multi-pass Cross-finned Tube								
Piping Design	Height Difference Between ODU and IDU	m(above)	50 (90m ²)						
		m(below)	40 (90m ²)						
	Height Difference Between IDUs	m	15 (30m ²)						
Max. Piping Length	m	1000							
Operation Range	Cooling ³	°C DB	-5~55						
	Heating ³	°C WB	-25~-16.5						

Hi-FLEXi S+ Series High Ambient



HP		66	68	70	72	
Model	Model	AVWT-634MHKFSE	AVWT-654MHKFSE	AVWT-676MHKFSE	AVWT-696MHKFSE	
	Modules	AVWT-170MHKFSE	AVWT-190MHKFSE	AVWT-212MHKFSE	AVWT-232MHKFSE	
		AVWT-232MHKFSE	AVWT-232MHKFSE	AVWT-232MHKFSE	AVWT-232MHKFSE	
		AVWT-232MHKFSE	AVWT-232MHKFSE	AVWT-232MHKFSE	AVWT-232MHKFSE	
Power Supply		AC 3φ 380V~415V/50Hz/60Hz				
Cooling	Nominal Capacity T1 35°C	kW	186.0	192.0	197.5	204.0
		Btu/h	635000	655000	675000	695000
	Actual Capacity T3 46°C	kW	159.8	165.6	170.0	174.0
		Btu/h	545000	565000	580000	595000
	Power Consumption T1 35°C	kW	45.25	46.49	47.89	49.50
	Power Consumption T3 46°C	kW	56.89	59.10	61.13	63.06
EER T1 35°C	Btu/(W-h)	14.05	14.10	14.10	14.05	
EER T3 46°C	Btu/(W-h)	9.60	9.55	9.50	9.45	
Heating	Capacity	kW	206.0	213.0	219.0	225.0
	Btu/h	705000	725000	745000	770000	
	Power Consumption	kW	66.15	69.05	71.66	73.77
COP	kW/kW	3.11	3.08	3.06	3.05	
Fan	Air Flow Rate	m³/min	792	859	888	888
	Fan Quantity		2+2+2	2+2+2	2+2+2	2+2+2
	Fan Style		DC Inverter			
	Static Pressure	Pa	110			
Sound	Sound Pressure Level ¹	dB(A)	69	69	69	70
	Type		Scroll Comp.			
Compressor	Type		Scroll Comp.			
	Compressor Quantity	PC	1+2+2	2+2+2	2+2+2	2+2+2
Refrigerant	Type		R410A			
	Pre-charged Quantity	kg	11.1+12.7+12.7	11.8+12.7+12.7	12.7+12.7+12.7	12.7+12.7+12.7
Weight	Net Weight	kg	293+365+365	363+365+365	364+365+365	365+365+365
	Gross Weight	kg	327+403+403	401+403+403	402+403+403	403+403+403
Dimensions	External (H×W×D)	mm	1730×(1210+1350+1350)×750	1730×(1350+1350+1350)×750		
	Packing (H×W×D)	mm	1950×(1275+1420+1420)×790	1950×(1420+1420+1420)×790		
Ref. Piping	Gas	mm	φ44.5	φ50.8	φ50.8	φ50.8
	Liquid	mm	φ22.2	φ25.4	φ25.4	φ25.4
	Pressure (High/Low Pressure)	MPa	4.15/2.21	4.15/2.21	4.15/2.21	4.15/2.21
Connectable Indoor Units	Quantity	PC	64	64	64	64
Crankcase Heater Capacity	kW	0.40	0.48	0.48	0.48	
Refrigerant Flow Control		Micro-computer Control Expansion Valve				
Heat Exchanger Type		Multi-pass Cross-finned Tube				
Piping Design	Height Difference Between ODU and IDU	m(above)	50 (90m ²)			
		m(below)	40 (90m ²)			
	Height Difference Between IDUs	m	15 (30m ²)			
	Max. Piping Length	m	1000			
Operation Range	Cooling ³	°C DB	-5~55			
	Heating ³	°C WB	-25~16.5			

Notes: The above cooling and heating capacities show the capacities when the outdoor unit is operated with the 100% rating of indoor units,
 Cooling Operation Conditions (T1) Cooling Operation Conditions (T3) Heating Operation Conditions
 Indoor Air Inlet Temperature: 27°C DB / 19°C WB Indoor Air Inlet Temperature: 29°C DB / 19°C WB Indoor Air Inlet Temperature: 20°C DB / 15°C WB
 Outdoor Air Inlet Temperature: 35°C DB / 24°C WB Outdoor Air Inlet Temperature: 46°C DB / 24°C WB Outdoor Air Inlet Temperature: 7°C DB / 6°C WB
 Piping Length: 7.5 meters, Piping Lift: 0 meter
¹The above noise values are measured in the anechoic chamber without reflected echo, therefore the impact of the reflected echo must be included at the scene.
 Measurement point: 1 meter from the service cover surface and 1.5 meters from floor level.
²For detailed information, please contact Hisense's technical staff.
³Operation Control Range: 52°C~55°C / -25°C~-20°C.

Hi-FLEXi S+ Series High Ambient



HP		74	76	78	80	
Model	Model	AVWT-714MHKFSE	AVWT-732MHKFSE	AVWT-754MHKFSE	AVWT-776MHKFSE	
	Modules	AVWT-232MHKFSE	AVWT-232MHKFSE	AVWT-232MHKFSE	AVWT-232MHKFSE	
		AVWT-232MHKFSE	AVWT-250MHKFSE	AVWT-250MHKFSE	AVWT-272MHKFSE	
		AVWT-250MHKFSE	AVWT-250MHKFSE	AVWT-272MHKFSE	AVWT-272MHKFSE	
Power Supply		AC 3φ 380V~415V/50Hz/60Hz				
Cooling	Nominal Capacity T1 35°C	kW	208.5	213.0	220.5	228.0
		Btu/h	710000	725000	750000	780000
	Actual Capacity T3 46°C	kW	179.5	185.0	189.5	194.0
		Btu/h	610000	630000	645000	660000
	Power Consumption T1 35°C	kW	51.90	54.30	56.40	58.50
	Power Consumption T3 46°C	kW	64.14	65.22	67.48	69.74
EER T1 35°C	Btu/(W-h)	13.70	13.35	13.30	13.35	
EER T3 46°C	Btu/(W-h)	9.50	9.65	9.55	9.45	
Heating	Capacity	kW	230.0	235.0	245.0	255.0
	Btu/h	785000	800000	835000	870000	
	Power Consumption	kW	76.03	78.29	83.02	87.75
COP	kW/kW	3.03	3.00	2.95	2.91	
Fan	Air Flow Rate	m³/min	942	996	996	996
	Fan Quantity		2+2+2	2+2+2	2+2+2	2+2+2
	Fan Style		DC Inverter			
	Static Pressure	Pa	110			
Sound	Sound Pressure Level ¹	dB(A)	70	70	71	71
	Type		Scroll Comp.			
Compressor	Type		Scroll Comp.			
	Compressor Quantity	PC	2+2+2	2+2+2	2+2+2	2+2+2
Refrigerant	Type		R410A			
	Pre-charged Quantity	kg	12.7+12.7+13.5	12.7+13.5+13.5	12.7+13.5+13.5	12.7+13.5+13.5
Weight	Net Weight	kg	365+365+389	365+389+389	365+389+390	365+390+390
	Gross Weight	kg	403+403+433	403+433+433	403+433+434	403+434+434
Dimensions	External (H×W×D)	mm	1730×(1350+1350+1600)×750	1730×(1350+1600+1600)×750		
	Packing (H×W×D)	mm	1950×(1420+1420+1665)×790	1950×(1420+1665+1665)×790		
Ref. Piping	Gas	mm	φ50.8	φ50.8	φ50.8	φ50.8
	Liquid	mm	φ25.4	φ25.4	φ25.4	φ25.4
	Pressure (High/Low Pressure)	MPa	4.15/2.21	4.15/2.21	4.15/2.21	4.15/2.21
Connectable Indoor Units	Quantity	PC	64	64	64	64
Crankcase Heater Capacity	kW	0.48	0.48	0.48	0.48	
Refrigerant Flow Control		Micro-computer Control Expansion Valve				
Heat Exchanger Type		Multi-pass Cross-finned Tube				
Piping Design	Height Difference Between ODU and IDU	m(above)	50 (90m ²)			
		m(below)	40 (90m ²)			
	Height Difference Between IDUs	m	15 (30m ²)			
	Max. Piping Length	m	1000			
Operation Range	Cooling ³	°C DB	-5~55			
	Heating ³	°C WB	-25~16.5			

Hi-FLEXi S+ Series High Ambient



HP		82	84	86	88	
Model	Model	AVWT-794MHKFSE	AVWT-816MHKFSE	AVWT-824MHKFSE	AVWT-844MHKFSE	
	Modules	AVWT-250MHKFSE	AVWT-272MHKFSE	AVWT-190MHKFSE	AVWT-190MHKFSE	
		AVWT-272MHKFSE	AVWT-272MHKFSE	AVWT-190MHKFSE	AVWT-190MHKFSE	
		AVWT-272MHKFSE	AVWT-272MHKFSE	AVWT-212MHKFSE	AVWT-232MHKFSE	
Power Supply		AC 3φ 380V-415V/50Hz/60Hz				
Cooling	Nominal Capacity T1 35°C	kW	232.5	240.0	241.5	248.0
		Btu/h	795000	820000	825000	845000
	Actual Capacity T3 46°C	kW	199.5	204.0	211.2	215.2
		Btu/h	680000	695000	720000	735000
	Power Consumption T1 35°C	kW	60.90	63.00	58.37	59.98
	Power Consumption T3 46°C	kW	70.82	73.08	74.23	76.16
EER T1 35°C	Btu/(W-h)	13.05	13.00	14.15	14.10	
EER T3 46°C	Btu/(W-h)	9.60	9.50	9.70	9.65	
Heating	Capacity	kW	260.0	270.0	270.0	276.0
	Power Consumption	kW	90.01	94.74	86.81	88.92
	COP	kW/kW	2.89	2.85	3.11	3.10
Fan	Air Flow Rate	m³/min	1050	1050	1126	1126
	Fan Quantity		2+2+2	2+2+2	2+2+2+2	2+2+2+2
	Fan Style		DC Inverter			
Static Pressure	Pa	110				
Sound	Sound Pressure Level ¹	dB(A)	71	72	70	70
Compressor	Type	Scroll Comp.				
	Compressor Quantity	PC	2+2+2	2+2+2	2+2+2+2	2+2+2+2
Refrigerant	Type	R410A				
	Pre-charged Quantity	kg	13.5+13.5+13.5	13.5+13.5+13.5	11.8+11.8+12.7+12.7	11.8+11.8+12.7+12.7
Weight	Net Weight	kg	389+390+390	390+390+390	363+363+364+365	363+363+365+365
	Gross Weight	kg	433+434+434	434+434+434	401+401+402+403	401+401+403+403
Dimensions	External (H×W×D)	mm	1730×(1600+1600+1600)×750		1730×(1350+1350+1350+1350)×750	
	Packing (H×W×D)	mm	1950×(1665+1665+1665)×790		1950×(1420+1420+1420+1420)×790	
Ref. Piping	Gas	mm	φ50.8	φ50.8	φ50.8	φ50.8
	Liquid	mm	φ25.4	φ25.4	φ25.4	φ25.4
	Pressure (High/Low Pressure)	MPa	4.15/2.21	4.15/2.21	4.15/2.21	4.15/2.21
Connectable Indoor Units	Quantity	PC	64	64	64	64
Crankcase Heater Capacity	kW	0.48	0.48	0.64	0.64	
Refrigerant Flow Control		Micro-computer Control Expansion Valve				
Piping Design	Heat Exchanger Type	Multi-pass Cross-finned Tube				
		Height Difference Between ODU and IDU	m(above)	50 (90m ²)		
	Height Difference Between IDUs	m(below)	40 (90m ²)			
		m	15 (30m ²)			
Max. Piping Length	m	1000				
Operation Range	Cooling ³	°C DB	-5-55			
	Heating ³	°C WB	-25-16.5			

Notes: The above cooling and heating capacities show the capacities when the outdoor unit is operated with the 100% rating of indoor units, Cooling Operation Conditions (T1) Cooling Operation Conditions (T3) Heating Operation Conditions
 Indoor Air Inlet Temperature: 27°C DB / 19°C WB Indoor Air Inlet Temperature: 29°C DB / 19°C WB Indoor Air Inlet Temperature: 20°C DB / 15°C WB
 Outdoor Air Inlet Temperature: 35°C DB / 24°C WB Outdoor Air Inlet Temperature: 46°C DB / 24°C WB Outdoor Air Inlet Temperature: 7°C DB / 6°C WB
 Piping Length: 7.5 meters, Piping Lift: 0 meter
¹The above noise values are measured in the anechoic chamber without reflected echo, therefore the impact of the reflected echo must be included at the scene.
 Measurement point: 1 meter from the service cover surface and 1.5 meters from floor level.
²For detailed information, please contact Hisense's technical staff.
³Operation Control Range: 52°C-55°C / -25°C--20°C.

Hi-FLEXi S+ Series High Ambient



HP		90	92	94	96	
Model	Model	AVWT-866MHKFSE	AVWT-886MHKFSE	AVWT-908MHKFSE	AVWT-928MHKFSE	
	Modules	AVWT-190MHKFSE	AVWT-190MHKFSE	AVWT-212MHKFSE	AVWT-232MHKFSE	
		AVWT-212MHKFSE	AVWT-232MHKFSE	AVWT-232MHKFSE	AVWT-232MHKFSE	
		AVWT-232MHKFSE	AVWT-232MHKFSE	AVWT-232MHKFSE	AVWT-232MHKFSE	
Power Supply		AC 3φ 380V-415V/50Hz/60Hz				
Cooling	Nominal Capacity T1 35°C	kW	253.5	260.0	265.5	272.0
		Btu/h	865000	885000	905000	930000
	Actual Capacity T3 46°C	kW	219.6	223.6	228.0	232.0
		Btu/h	750000	765000	780000	790000
	Power Consumption T1 35°C	kW	61.38	62.99	64.39	66.00
	Power Consumption T3 46°C	kW	78.19	80.12	82.15	84.08
EER T1 35°C	Btu/(W-h)	14.10	14.05	14.05	14.10	
EER T3 46°C	Btu/(W-h)	9.60	9.55	9.50	9.40	
Heating	Capacity	kW	282.0	288.0	294.0	300.0
	Power Consumption	kW	91.53	93.64	96.25	98.36
	COP	kW/kW	3.08	3.08	3.05	3.05
Fan	Air Flow Rate	m³/min	1155	1155	1184	1184
	Fan Quantity		2+2+2+2	2+2+2+2	2+2+2+2	2+2+2+2
	Fan Style		DC Inverter			
Static Pressure	Pa	110				
Sound	Sound Pressure Level ¹	dB(A)	70	71	71	71
Compressor	Type	Scroll Comp.				
	Compressor Quantity	PC	2+2+2+2	2+2+2+2	2+2+2+2	2+2+2+2
Refrigerant	Type	R410A				
	Pre-charged Quantity	kg	11.8+12.7+12.7+12.7	11.8+12.7+12.7+12.7	12.7+12.7+12.7+12.7	12.7+12.7+12.7+12.7
Weight	Net Weight	kg	363+364+365+365	363+365+365+365	364+365+365+365	365+365+365+365
	Gross Weight	kg	401+402+403+403	401+403+403+403	402+403+403+403	403+403+403+403
Dimensions	External (H×W×D)	mm	1730×(1350+1350+1350+1350)×750			
	Packing (H×W×D)	mm	1950×(1420+1420+1420+1420)×790			
Ref. Piping	Gas	mm	φ50.8	φ50.8	φ50.8	φ50.8
	Liquid	mm	φ25.4	φ25.4	φ25.4	φ25.4
	Pressure (High/Low Pressure)	MPa	4.15/2.21	4.15/2.21	4.15/2.21	4.15/2.21
Connectable Indoor Units	Quantity	PC	64	64	64	64
Crankcase Heater Capacity	kW	0.64	0.64	0.64	0.64	
Refrigerant Flow Control		Micro-computer Control Expansion Valve				
Piping Design	Heat Exchanger Type	Multi-pass Cross-finned Tube				
		Height Difference Between ODU and IDU	m(above)	50 (90m ²)		
	Height Difference Between IDUs	m(below)	40 (90m ²)			
		m	15 (30m ²)			
Max. Piping Length	m	1000				
Operation Range	Cooling ³	°C DB	-5-55			
	Heating ³	°C WB	-25-16.5			

Hi-FLEXi S+ Series High Ambient



HP		98	100	102	104	
Model	Model	AVWT-946MHKFSE	AVWT-968MHKFSE	AVWT-986MHKFSE	AVWT-1008MHKFSE	
	Modules	AVWT-232MHKFSE	AVWT-232MHKFSE	AVWT-232MHKFSE	AVWT-232MHKFSE	
		AVWT-232MHKFSE	AVWT-232MHKFSE	AVWT-232MHKFSE	AVWT-232MHKFSE	
		AVWT-232MHKFSE	AVWT-232MHKFSE	AVWT-250MHKFSE	AVWT-272MHKFSE	
		AVWT-250MHKFSE	AVWT-272MHKFSE	AVWT-272MHKFSE	AVWT-272MHKFSE	
Power Supply		AC 3Φ 380V~415V/50Hz/60Hz				
Cooling	Nominal Capacity T1 35°C	kW	276.5	284.0	288.5	296.0
		Btu/h	945000	970000	985000	1010000
	Actual Capacity T3 46°C	kW	237.5	242.0	247.5	252.0
		Btu/h	810000	825000	845000	860000
	Power Consumption T1 35°C	kW	68.40	70.50	72.90	75.00
	Power Consumption T3 46°C	kW	85.16	87.42	88.50	90.76
EER T1 35°C	Btu/(W·h)	13.80	13.75	13.50	13.45	
EER T3 46°C	Btu/(W·h)	9.50	9.45	9.55	9.50	
Heating	Capacity	kW	305.0	315.0	320.0	330.0
		Btu/h	1040000	1075000	1090000	1125000
	Power Consumption	kW	100.62	105.35	107.61	112.34
	COP	kW/kW	3.03	2.99	2.97	2.94
Fan	Air Flow Rate	m³/min	1238	1238	1292	1292
	Fan Quantity		2+2+2+2	2+2+2+2	2+2+2+2	2+2+2+2
	Fan Style		DC Inverter			
	Static Pressure	Pa	110			
Sound	Sound Pressure Level ¹	dB(A)	71	72	72	72
Compressor	Type		Scroll Comp.			
	Compressor Quantity	PC	2+2+2+2	2+2+2+2	2+2+2+2	2+2+2+2
Refrigerant	Type		R410A			
	Pre-charged Quantity	kg	12.7+12.7+12.7+13.5	12.7+12.7+12.7+13.5	12.7+12.7+13.5+13.5	12.7+12.7+13.5+13.5
Weight	Net Weight	kg	365+365+365+389	365+365+365+390	365+365+389+390	365+365+390+390
	Gross Weight	kg	403+403+403+433	403+403+403+434	403+403+433+434	403+403+434+434
Dimensions	External (H×W×D)	mm	1730×(1350+1350+1350+1600)×750		1730×(1350+1350+1600+1600)×750	
	Packing (H×W×D)	mm	1950×(1420+1420+1420+1665)×790		1950×(1420+1420+1665+1665)×790	
Ref. Piping	Gas	mm	φ50.8	φ50.8	φ50.8	φ50.8
	Liquid	mm	φ25.4	φ25.4	φ25.4	φ25.4
	Pressure (High/Low Pressure)	MPa	4.15/2.21	4.15/2.21	4.15/2.21	4.15/2.21
Connectable Indoor Units	Quantity	PC	64	64	64	64
Crankcase Heater Capacity	kW	0.64	0.64	0.64	0.64	
Refrigerant Flow Control		Micro-computer Control Expansion Valve				
Piping Design	Heat Exchanger Type		Multi-pass Cross-finned Tube			
		Height Difference Between ODU and IDU	m(above)	50 (90m ²)		
		m(below)	40 (90m ²)			
	Height Difference Between IDUs	m	15 (30m ²)			
	Max. Piping Length	m	1000			
Operation Range	Cooling ³	°C DB	-5~55			
	Heating ³	°C WB	-25~-16.5			

Hi-FLEXi S+ Series High Ambient



HP		106	108	110	112	
Model	Model	AVWT-1026MHKFSE	AVWT-1048MHKFSE	AVWT-1066MHKFSE	AVWT-1088MHKFSE	
	Modules	AVWT-232MHKFSE	AVWT-232MHKFSE	AVWT-250MHKFSE	AVWT-272MHKFSE	
		AVWT-250MHKFSE	AVWT-272MHKFSE	AVWT-272MHKFSE	AVWT-272MHKFSE	
		AVWT-272MHKFSE	AVWT-272MHKFSE	AVWT-272MHKFSE	AVWT-272MHKFSE	
		AVWT-272MHKFSE	AVWT-272MHKFSE	AVWT-272MHKFSE	AVWT-272MHKFSE	
Power Supply		AC 3Φ 380V~415V/50Hz/60Hz				
Cooling	Nominal Capacity T1 35°C	kW	300.5	308.0	312.5	320.0
		Btu/h	1025000	1050000	1065000	1090000
	Actual Capacity T3 46°C	kW	257.5	262.0	267.5	272.0
		Btu/h	880000	895000	915000	930000
	Power Consumption T1 35°C	kW	77.40	79.50	81.90	84.00
	Power Consumption T3 46°C	kW	91.84	94.10	95.18	97.44
EER T1 35°C	Btu/(W·h)	13.25	13.20	13.00	13.00	
EER T3 46°C	Btu/(W·h)	9.60	9.50	9.60	9.55	
Heating	Capacity	kW	335.0	345.0	350.0	360.0
		Btu/h	1145000	1175000	1195000	1230000
	Power Consumption	kW	114.60	119.33	121.59	126.32
	COP	kW/kW	2.92	2.89	2.88	2.85
Fan	Air Flow Rate	m³/min	1346	1346	1400	1400
	Fan Quantity		2+2+2+2	2+2+2+2	2+2+2+2	2+2+2+2
	Fan Style		DC Inverter			
	Static Pressure	Pa	110			
Sound	Sound Pressure Level ¹	dB(A)	72	73	73	73
Compressor	Type		Scroll Comp.			
	Compressor Quantity	PC	2+2+2+2	2+2+2+2	2+2+2+2	2+2+2+2
Refrigerant	Type		R410A			
	Pre-charged Quantity	kg	12.7+13.5+13.5+13.5	12.7+13.5+13.5+13.5	13.5+13.5+13.5+13.5	13.5+13.5+13.5+13.5
Weight	Net Weight	kg	365+389+390+390	365+390+390+390	389+390+390+390	390+390+390+390
	Gross Weight	kg	403+433+434+434	403+434+434+434	433+434+434+434	434+434+434+434
Dimensions	External (H×W×D)	mm	1730×(1350+1600+1600+1600)×750		1730×(1600+1600+1600+1600)×750	
	Packing (H×W×D)	mm	1950×(1420+1665+1665+1665)×790		1950×(1665+1665+1665+1665)×790	
Ref. Piping	Gas	mm	φ50.8	φ50.8	φ50.8	φ50.8
	Liquid	mm	φ25.4	φ25.4	φ25.4	φ25.4
	Pressure (High/Low Pressure)	MPa	4.15/2.21	4.15/2.21	4.15/2.21	4.15/2.21
Connectable Indoor Units	Quantity	PC	64	64	64	64
Crankcase Heater Capacity	kW	0.64	0.64	0.64	0.64	
Refrigerant Flow Control		Micro-computer Control Expansion Valve				
Piping Design	Heat Exchanger Type		Multi-pass Cross-finned Tube			
		Height Difference Between ODU and IDU	m(above)	50 (90m ²)		
		m(below)	40 (90m ²)			
	Height Difference Between IDUs	m	15 (30m ²)			
	Max. Piping Length	m	1000			
Operation Range	Cooling ³	°C DB	-5~55			
	Heating ³	°C WB	-25~-16.5			

Notes: The above cooling and heating capacities show the capacities when the outdoor unit is operated with the 100% rating of indoor units, Cooling Operation Conditions (T1) Cooling Operation Conditions (T3) Heating Operation Conditions
 Indoor Air Inlet Temperature: 27°C DB / 19°C WB Indoor Air Inlet Temperature: 29°C DB / 19°C WB Indoor Air Inlet Temperature: 20°C DB / 15°C WB
 Outdoor Air Inlet Temperature: 35°C DB / 24°C WB Outdoor Air Inlet Temperature: 46°C DB / 24°C WB Outdoor Air Inlet Temperature: 7°C DB / 6°C WB
 Piping Length: 7.5 meters, Piping Lift: 0 meter
¹The above noise values are measured in the anechoic chamber without reflected echo, therefore the impact of the reflected echo must be included at the scene.
 Measurement point: 1 meter from the service cover surface and 1.5 meters from floor level.
²For detailed information, please contact Hisense's technical staff.
³Operation Control Range: 52°C~55°C / -25°C~-20°C.

Hi-Smart H Series High Ambient



Hi-Smart H Series High Ambient creates a high-quality quiet environment. The design of the grilling follows the design concept of the aircraft engine design, which conforms to the aerodynamics principle. The noise has been greatly reduced. The grilling also increases safety as being a preventative for child finger being injured by the fan blade.

DC Inverter Compressor

High-efficiency full DC inverter compressor is used for products of Hisense Hi-Smart H Series High Ambient, whose motor is more efficient and energy-saving. The compressor has a special anti-vibration structure design, ensuring stable operation, small vibration and a long service life. The design promotes the high reliability and low noise of outdoor unit, greatly improving user experience.

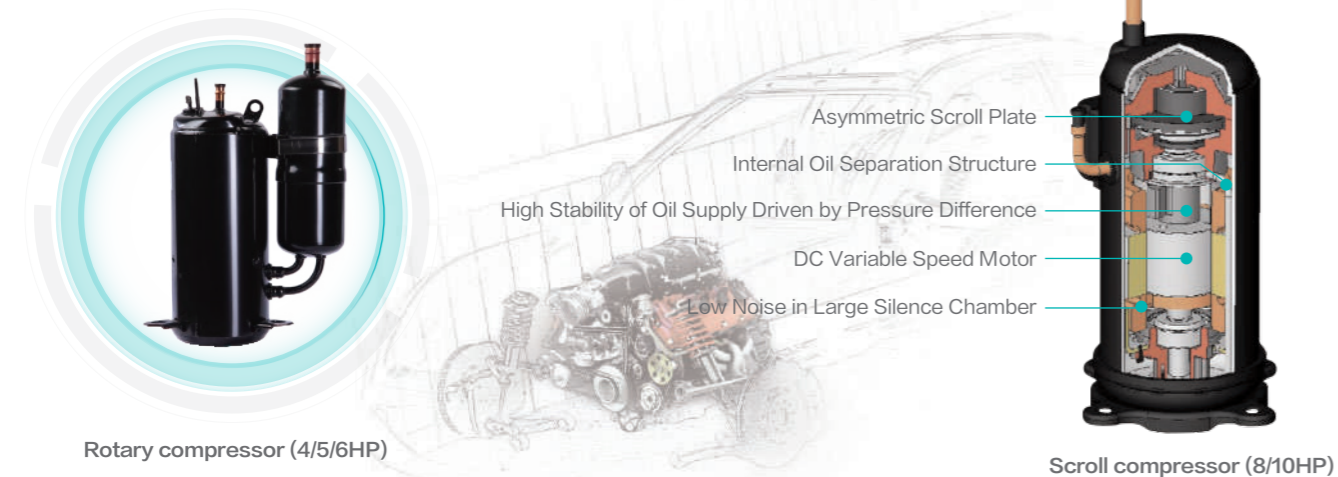

Hi-Smart H Series High Ambient

Slim and Refined Body Design

The compact outdoor unit can be flexibly placed according to outdoor condition. Low-height ducted type can be easily installed inside the low-height residential ceiling with a height of 192mm, which makes low height indoor units and elegant home decoration style set off mutually.



High Quality PCB Baseplate

To create high-quality electronic control board through rigorous testing: electronic control board runs for 1000 hours under the temperature of 60°C, and relative humidity of 95%. Outstanding performance of core components is ensured through rigorous testing.

Epoxy resin composite baseplate: printed on both sides and SMT welding; high strength, strong weather resistance, good flame resistance and high reliability; compact structure with small volume.

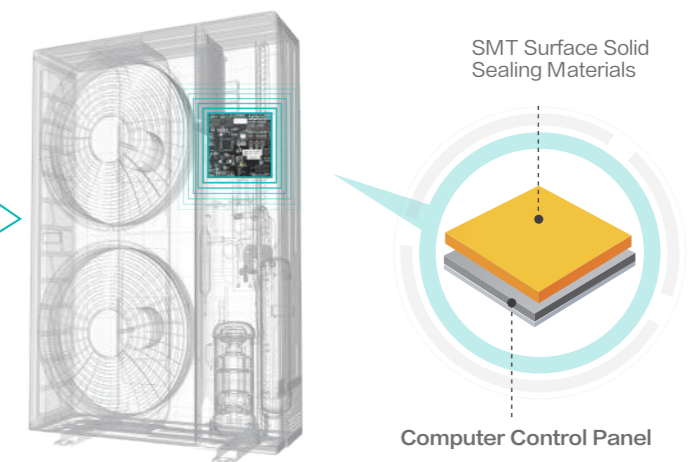

Hi-Smart H Series High Ambient

Long Piping Design

Long refrigerant piping design makes project design and installation works more convenient.

* Detailed value please refer to the parameter of outdoor units.

- Total piping length can be 120m.
- Max. height difference between outdoor and indoor units is 50m.
- Max. piping length is 100m.
- Max. height difference between the highest and the lowest indoor units is 15m.



Flexible Piping Connection

Installation restrictions on site does not stop Hisense mini VRF there with flexible piping directions which includes front, bottom, right, rear connections.



Hi-Smart H Series High Ambient



HP		4	5	6	8	10	
Model		AVW-38UJSCA	AVW-48UJSCA	AVW-54UJSCA	AVW-76UESRA	AVW-96UESRA	
Power Supply		AC1 220-240V 50/60Hz			AC3 380-415V/50Hz		
Cooling T1 35°C	Capacity	Ton	3.2	4.0	4.4	6.4	8.0
	Capacity	kW	11.1	13.9	15.4	22.3	28.1
	Capacity	Btu/h	38000	47500	52500	76000	96000
	EER	Btu/(Wh)	12.80	12.00	11.60	12.20	11.60
Cooling T3 46°C	PI	kW	2.97	3.96	4.53	6.23	8.28
	Capacity	kW	9.7	12.2	13.5	16.7	18.2
	Capacity	Btu/h	33000	41500	46000	57000	62000
	EER	Btu/(Wh)	10.50	9.93	9.31	9.78	9.28
Heating	PI	kW	3.14	4.18	4.94	5.83	6.68
	Capacity	kW	12.5	16	18	25	31.5
	Capacity	Btu/h	42700	54600	61400	85300	107500
	COP	(Btu/h)/W	14.4	13.6	12.9	13.6	13.0
	PI	kW	2.97	4.01	4.77	6.25	8.29
Air Flow Rate		m³/h	5400	5400	6000	9780	9780
Outer Dimensions	H × W × D	mm	1380 × 950 × 370			1650 × 1100 × 390	
Packing Dimensions	H × W × D	mm	1520 × 1025 × 460			1748 × 1151 × 500	
Net Weight	Unit	kg	93	95	97	171	171
Gross Weight	Unit	kg	106	108	110	182	182
Compressor Quantity			1				
Compressor Type			Rotary Compressor			Scroll Compressor	
Condenser Fan Quantity			2				
Cabinet Color			Ivory White				
Refrigerant Piping	Gas Line	mm	φ15.88			φ19.05	φ22.2
	Liquid Line	mm	φ9.53			φ9.53	φ12.7
Max. Connectable Indoor Units			7(9)*			10	
Max. Piping Length		m	75			100	
Height Difference	Between ODU&IDU	m	30			50(40)	
	Between IDUs	m	15			15	
Sound Level	Sound Power	dB(A)	64	65	66	70	71
	Sound Pressure	dB(A)	50	51	52	54	55
Operation Range Cooling			-5°C~55°C				
Operation Range Heating			-20°C~16.5°C				

Notes:

1.The cooling and heating performances are the values when combined with our specified indoor units (Piping length : 7.5 Meters, Piping lift : 0 Meter).

(1)Cooling Operation Conditions: Indoor Air Inlet Temperature 26.7°C DB/ 19.4°C WB, Outdoor Ambient Temperature 35°C DB.

(2)Cooling Operation Conditions: Indoor Air Inlet Temperature 29.0°C DB/ 19.0°C WB, Outdoor Ambient Temperature 46°C DB.

(3)Heating Operation Conditions: Indoor Air Inlet Temperature 20°C DB, Outdoor Ambient Temperature 7°C DB/ 6°C WB.

2. If you have any questions, please contact our engineers.

Indoor Unit



4-way Cassette Type

Mini 4-way Cassette Type

Ceiling Ducted Type

AC Low-height

DC Low-height

High Static Pressure

Low Static Pressure

1-way Cassette Type

2-way Cassette Type

Console Type

Wall Mounted Type

Ceiling & Floor Type

Floor Concealed Type

All Fresh Air Indoor Unit

Heat Recovery Ventilator

AHU Connection Kit

Functions & Accessories

Installation & Maintenance



1200mm condensate pump

Drain Pumps help to discharge condensate water from the indoor unit smoothly.



Self-Diagnosis

The self-diagnosis function in indoor units smartly determines and analyses problems occurred providing with troubleshooting hints. It is displayable and could be tracked on controller, outdoor and indoor unit itself.



Compact size

Compact size on indoor units offer greater installation flexibility especially in restricted space.



Easy cleaning

Clean effortlessly by dragging cloths across smooth flat surfaces on indoor units and prevents heavy dust accumulation.



Large capacity range

Indoor unit series with large capacity range offer more capacity options to closely satisfy various indoor loads.



Auto restart

Indoor units with Auto Restart Function, automatically restarts in default mode or restoring to the previous mode after any involuntary power cut off.



Low temperature cooling

Setting temperature of indoor units is widen with selectable temperature to as low as 16°C.



Wireless receiver

Indoor units compatible to an optional wireless receiver to enable remote control when an wireless control is not the standard controller of the unit.



Humidity sensor (optional)

Indoor units compatible with humidity sensor accessory could access to Auto Dehumidification function on the indoor unit.



Hi-Motion (optional)

Hi-Motion is an human presence sensor optional accessory which enables auto airflow direction, auto ON/OFF, auto fan and setting based on human presence.



Remote control

Control indoor units remotely using the blind spotless LCD display wireless controller.



Silent operation

Indoor units that offer very low sound pressure levels during operation.



Adjustable louver's position

Louver's position of indoor units can be adjusted and fixed in different levels and angles.



3D Air-flow Panel

Selectable wind settings from normal, 3D and super long distance mode are available thanks to the 3D air-flow panel.



Six levels of fan speed

Six levels of fan speed are available.



Auto fan speed

Automatically controls rotation speed of fan depending on indoor load to achieve efficiency and comfort simultaneously.



Fresh air introduction

Indoor units that are compatible to introduce fresh air into rooms with either an optional adapter or direct connection to the air return segment of the unit.



Standard filter included

Washable long life synthetic fibre return air filters are included with the unit.



Optional filter

Washable long life synthetic fibre air filters does not come with indoor unit but an optional accessory.



AirPure (optional)

Achieving air purification by equipping with AirPure kit.

Basic Function

Air Quality

Indoor Unit



Indoor Unit

4-way Cassette Type



Mini 4-way Cassette Type



Compact and Classy Design

The 4-way cassette is now as slim as 238mm and 215mm for mini 4-way cassettes, fit for narrow ceiling spaces. Boring straight return air grille patterns are replaced with exquisite hexagon pattern design, upgrading taste and classiness of any interior aesthetic.

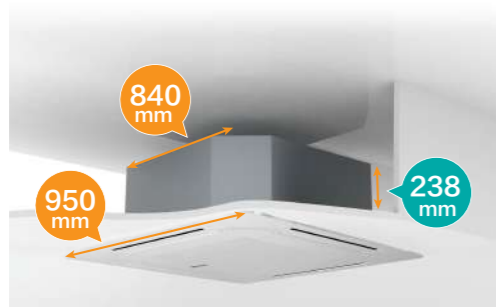

4-Way Cassette Type

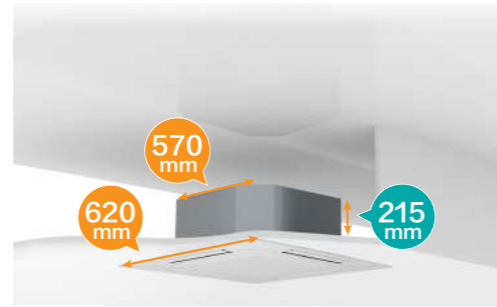

Mini 4-way Cassette Type

Higher Installation

Air from the cassette still manages to flow down from ceiling heights as high as 4.2m. Not to mention human presence and density detection by motion sensor at such height.

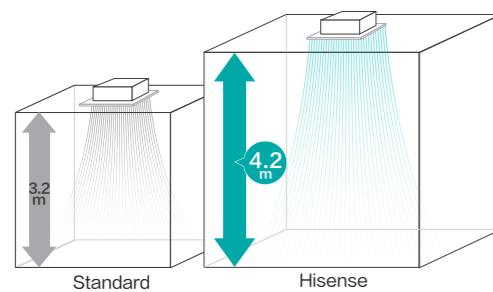

Branch Discharge Option

In irregular room layouts, branch discharge could come in handy by extending air distribution area to the most awkward corners without additional indoor units.



Individual Louvers Control

4-way cassettes louvers are now capable of individual control to freely choose how you want your AC unit supplies air according to different needs, applications and installation layout. Each louvers have 7 angle settings and maximum angle reach at 64°.

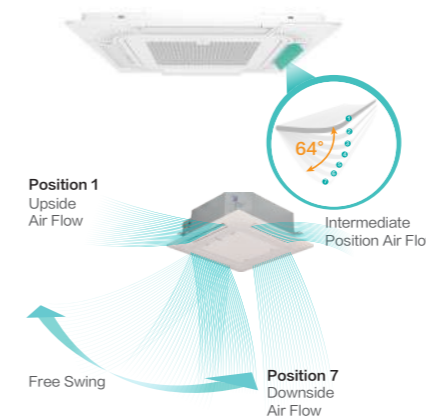

AirPure and Silver Ionizer

AirPure is a healthy alternative accessory to the normal conventional cassette unit to improve overall air quality. Airpure helps in improving skin condition, effective deodorizer and deactivating bacteria, virus and allergens floating in the air.

Silver ion accessory is also available to maintain the hygiene level of the drain pan preventing bacteria being transmitted out.

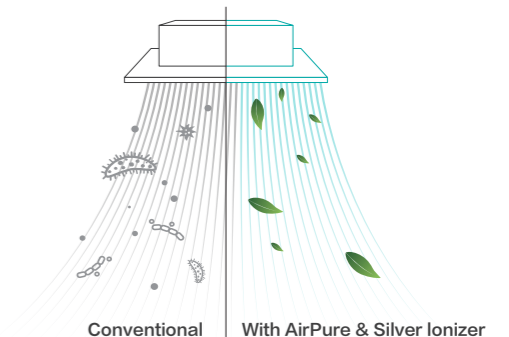

Motion Sensor

The sensor senses the presence of people to automatically turn the cassette unit on or off and whether to direct airflow towards or avoiding humans depend settings set on the controller. During crowded times, the setting temperature is automatically lowered down and vice versa. Meeting comfort and using energy only when necessary.

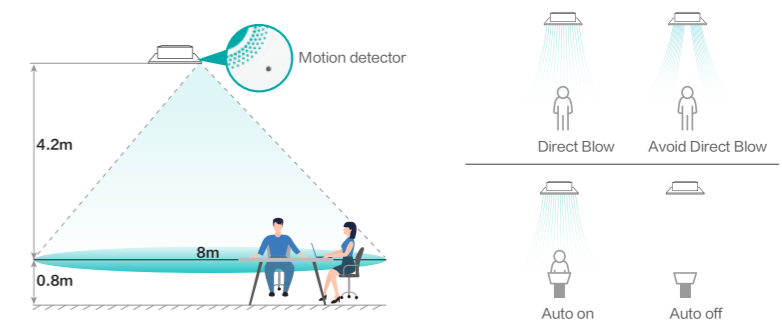

Indoor Unit

Indoor Unit

4-Way Cassette Type



Mini 4-Way Cassette Type



Model		AVBC-09 HJFKA	AVBC-12 HJFKA	AVBC-15 HJFKA	AVBC-19 HJFKA	AVBC-22 HJFKA	AVBC-24 HJFKA	AVBC-27 HJFKA	AVBC-30 HJFKA	AVBC-38 HJFKA	AVBC-48 HJFKA	AVBC-54 HJFKA	
Power Supply		AC 1ϕ, 220-240V/50Hz/60Hz											
Capacity	Cooling	kW	2.8	3.6	4.5	5.6	6.3	7.1	8.0	9.0	11.2	14.0	16.0
		Btu/h	9,600	12,300	15,400	19,100	21,500	24,200	27,300	30,700	38,200	47,800	54,600
Capacity	Heating	kW	3.2	4.0	5.0	6.3	7.1	8.0	9.0	10.0	12.5	16.0	18.0
		Btu/h	9,900	13,600	17,100	21,500	24,200	27,300	30,700	34,100	42,700	54,600	61,400
Power Input	Cooling	W	14	24	24	34	54	64	54	54	124	124	124
	Heating	W	14	24	24	34	54	64	54	54	124	124	124
Sound Pressure		dB(A)	30/28/28/ 27/26/26	32/29/29/ 28/27/26	33/31/29/ 29/27/26	34/31/30/ 28/28/26	36/33/32/ 31/29/28	36/33/32/ 31/29/28	37/36/35/ 33/31/30	37/36/35/ 33/31/30	42/40/38/ 36/34/33	46/44/40/ 38/36/34	46/44/41/ 40/38/36
Airflow Rate		L/s	250/223/ 200/180/ 167/147	283/233/ 213/197/ 180/152	350/267/ 248/227/ 212/187	367/292/ 265/258/ 227/208	433/333/ 305/283/ 252/217	450/350/ 318/300/ 272/245	450/367/ 338/312/ 280/257	450/383/ 345/327/ 295/268	617/500/ 457/413/ 373/327	617/558/ 493/453/ 403/373	617/567/ 512/482/ 427/397
Piping	Connection Type	-	Flare-nut Connection(With Flare Nuts)										
	Liquid	mm	ϕ6.35				ϕ9.53						
		in.	1/4				3/8						
	Gas	mm	ϕ12.7				ϕ15.88						
		in.	1/2				5/8						
Condensate Drain	mm	O.D.32											
Weight	Net Weight	kg	20	20	21	21	23	23	26	26	26	26	26
	Gross Weight	kg	24	24	25	25	27	27	31	31	31	31	31
Dimensions	External (H×W×D)	mm	238×840×840				288×840×840						
	Packaging (H×W×D)	mm	292×945×945				342×945×945						
Panel	Model	-	HP-G-NK										
	Panel Colour	-	Neutral White										
	Body Dimensions (H×W×D)	mm	47×950×950										
	Packaging Dimensions (H×W×D)	mm	105×1014×1014										
	Net Weight	kg	5.7										
	Gross Weight	kg	8										

NOTES: 1.The nominal cooling capacity and heating capacity are based on the following conditions:
Cooling Operation Conditions
Indoor Air Inlet Temperature: 27°C DB(80°F DB), 19.0°CWB(66.2°F WB)
Outdoor Air Inlet Temperature: 35°C DB(95°F DB)
Piping Length: 7.5 Meters Piping Lift: 0 Meter

Heating Operation Conditions
Indoor Air Inlet Temperature: 20°C DB(68°F DB)
Outdoor Air Inlet Temperature: 7°C DB(45°F DB), 6°C WB(43°F WB)
2.The sound pressure level is based on the following conditions: 1.5m beneath the unit.
The above data was measured in an anechoic chamber so that the reflected sound should be taken into consideration in the field.

Model		AVC-05HJFA	AVC-07HJFA	AVC-09HJFA	AVC-12HJFA	AVC-15HJFA	AVC-17HJFA	AVC-19HJFA	
Power Supply		AC 1ϕ, 220-240V/50Hz/60Hz							
Capacity	Cooling	kW	1.5	2.2	2.8	3.6	4.5	5.0	5.6
		Btu/h	5,100	7,480	9,520	12,240	15,300	17,000	19,040
Capacity	Heating	kW	2.0	2.5	3.3	4.2	5.0	5.6	6.3
		Btu/h	6,800	8,500	11,220	14,280	17,000	19,040	21,420
Power Input	Cooling	W	14	14	14	16	22	30	40
	Heating	W	14	14	14	16	22	30	40
Sound Pressure		dB(A)	30/29/28/26	30/29/28/26	32/30/28/26	34/32/29/26	38/36/31/28	42/39/36/31	45/42/38/34
Airflow Rate		L/s	119/108/103/93	119/108/103/93	131/119/108/97	136/119/108/97	156/146/118/111	183/158/146/118	208/181/156/133
Piping	Connection Type	-	Flare-nut Connection(With Flare Nuts)						
	Liquid	mm	ϕ6.35						
		in.	1/4						
	Gas	mm	ϕ12.7						
		in.	1/2						
Condensate Drain	mm	O.D.32							
Weight	Net Weight	kg	14.5	14.5	14.8	14.8	15.8	15.8	15.8
	Gross Weight	kg	17.3	17.3	17.6	17.6	18.6	18.6	18.6
Dimensions	External (H×W×D)	mm	215×570×570						
	Packaging (H×W×D)	mm	292×668×730						
Panel	Model	-	HPE-D-NK						
	Panel Colour	-	Neutral White						
	Body Dimensions (H×W×D)	mm	37×620×620						
	Packaging Dimensions (H×W×D)	mm	115×680×690						
	Net Weight	kg	2.7						
	Gross Weight	kg	4.5						

NOTES: 1.The nominal cooling capacity and heating capacity are based on the following conditions:
Cooling Operation Conditions
Indoor Air Inlet Temperature: 27°C DB(80°F DB), 19.0°CWB(66.2°F WB)
Outdoor Air Inlet Temperature: 35°C DB(95°F DB)
Piping Length: 7.5 Meters Piping Lift: 0 Meter

Heating Operation Conditions
Indoor Air Inlet Temperature: 20°C DB(68°F DB)
Outdoor Air Inlet Temperature: 7°C DB(45°F DB), 6°C WB(43°F WB)
2.The sound pressure level is based on the following conditions: 1.5m beneath the unit.
The above data was measured in an anechoic chamber so that the reflected sound should be taken into consideration in the field.

Indoor Unit



Indoor Unit

Ceiling Ducted Type

- AC Low-height
- DC Low-height



Ceiling Ducted Type

- High Static Pressure
- Low Static Pressure



Adjustable Static Pressure

Static pressures in free supply applications would create unnecessary air-blowing noises. Hence, the fan's static pressure is made adjustable to suit different applications more precisely with smaller steps.

NOTE: AC/DC Low-height and High/Low Static Pressure have different static pressure choices. Please refer to the specifications for more detail information.

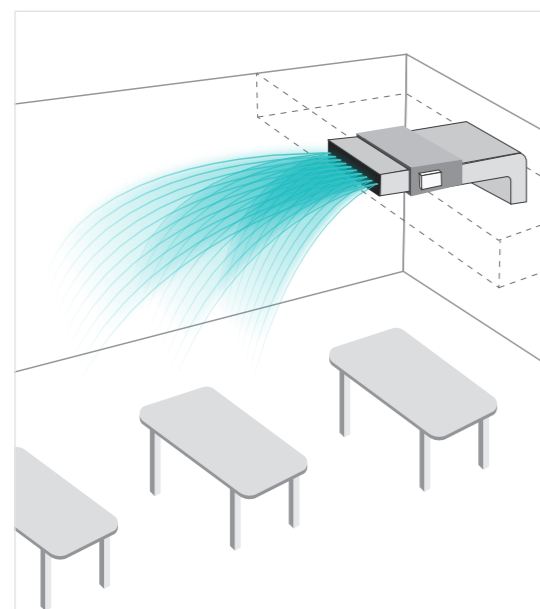

Satisfying Varied Requests on Installation

Free air introduction and air filter keep the indoor air clean.

NOTE: When bottom air inlet is adopted, sound pressure will increase according to factors such as installation mode and the room structure.

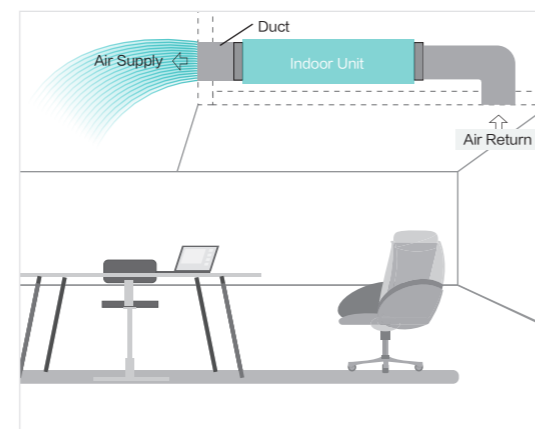

3D-Airflow

The 3D louvers on the panel offers wide air flow coverage to keep every corners of your room cool or warm in any seasons of the year.

NOTE: 3D-Airflow Panel is an optional accessory only for AC/DC Low-height. For more information please refer to Hisense engineers.

Smart & Precise Temperature Setting

To prevent the human height area of the room cools or warms to user's ideal temperature setting. Triple Temperature Sensor Control Technology is integrated into the unit whereby the controller, indoor unit supply and return section consist of built in temperature sensors to send real-time signals to the unit for a more precise supplying temperature.

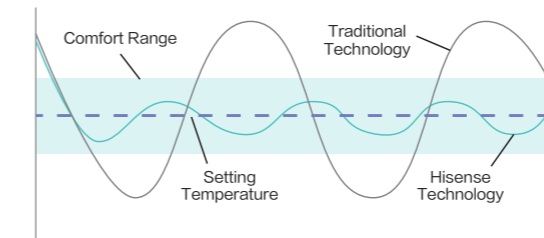

Standard Equipped Drain Pump

Standard equipped drain pump with the maximum drainage height up to 1200mm.

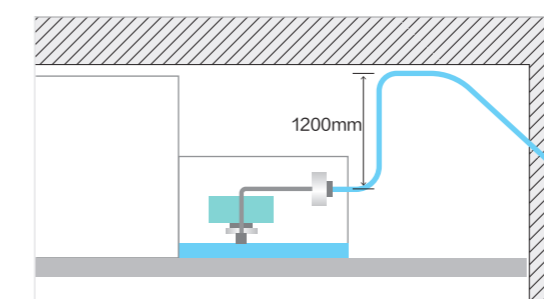

NOTE: Only for DC/AC low-height

Various Device Connection Options.

Third party devices and sensors to control the power supply is possible with dry contact connections to the indoor unit. Devices like Hotel room key card, window contact and fire alarms can be connected simultaneously.

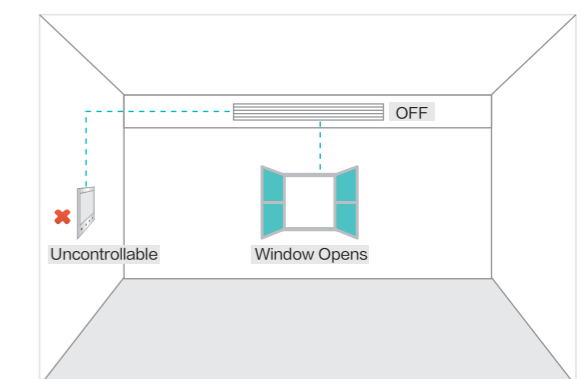
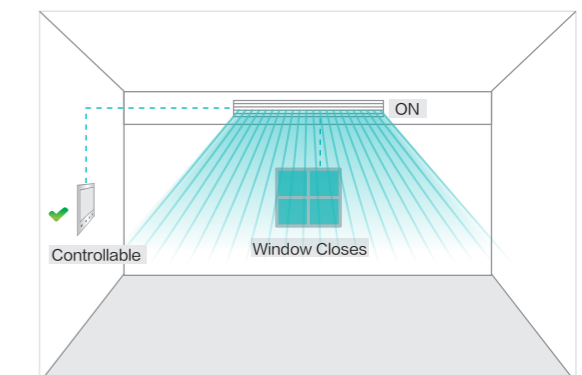

Indoor Unit

Ceiling Ducted Type

- AC Low-height



Model		AVE-05 HCFRL	AVE-07 HCFRL	AVE-09 HCFRL	AVE-12 HCFRL	AVE-15 HCFRL	AVE-17 HCFRL	AVE-19 HCFRL	AVE-22 HCFRL	AVE-24 HCFRL		
Power Supply		AC 1 ϕ , 220V-240V/50Hz										
Capacity	Cooling	kW	1.7	2.2	2.8	3.6	4.5	5.0	5.6	6.3	7.1	
		Btu/h	5,800	7,500	9,600	12,300	15,300	17,100	19,100	21,500	24,200	
	Heating	kW	1.9	2.5	3.2	4.0	5.0	5.6	6.3	7.1	8.0	
		Btu/h	6,500	8,500	11,300	13,600	17,100	19,100	21,500	24,200	27,300	
Power Input	Cooling	W	50	50	70	70	80	80	100	120	120	
	Heating	W	50	50	70	70	80	80	100	120	120	
Sound Pressure		dB(A)	29/24/22	29/24/22	35/25/23	35/25/23	36/25/23	36/25/23	35/25/23	39/26/25	39/26/25	
Airflow Rate		L/s	117/92/78	117/92/78	150/95/80	150/95/80	200/105/92	200/105/92	225/133/128	300/155/145	300/155/145	
External Static Pressure		Pa	10(30)									
Piping	Connection Type	-	Flare-nut Connection(With Flare Nuts)									
	Liquid	mm	ϕ 6.35			ϕ 6.35	ϕ 9.53	ϕ 9.53				
		in.	1/4			1/4	3/8	3/8				
	Gas	mm	ϕ 12.7			ϕ 15.88	ϕ 15.88	ϕ 15.88				
		in.	1/2			5/8	5/8	5/8				
Condensate Drain	mm	I.D.32										
Weight	Net Weight	kg	16	16	17	17	21	21	25	26	26	
	Gross Weight	kg	19	19	20	20	24	24	29	29	29	
Dimensions	External (H×W×D)	mm	192×700×447			192×910×447		192×1180×447				
	Packaging (H×W×D)	mm	270×925×574			270×1136×574		270×1406×574				

NOTES: 1.The nominal cooling capacity and heating capacity are based on the following conditions:
 Cooling Operation Conditions
 Indoor Air Inlet Temperature: 27°C DB(80°F DB), 19.0°CWB(66.2°F WB)
 Outdoor Air Inlet Temperature: 35°C DB(95°F DB)
 Piping Length: 7.5 Meters Piping Lift: 0 Meter

Heating Operation Conditions
 Indoor Air Inlet Temperature: 20°C DB(68°F DB).
 Outdoor Air Inlet Temperature: 7°C DB(45°F DB), 6°C WB(43°F WB)

2.The sound pressure level is based on the following conditions: 1.5m beneath the unit.
 The above data was measured in an anechoic chamber so that the reflected sound should be taken into consideration in the field.

Indoor Unit

Ceiling Ducted Type

- DC Low-height



Model		AVE-05 HJFDL	AVE-07 HJFDL	AVE-09 HJFDL	AVE-12 HJFDL	AVE-15 HJFDL	AVE-17 HJFDL	AVE-19 HJFDL	AVE-22 HJFDL	AVE-24 HJFDL		
Power Supply		AC 1 ϕ , 220V-240V/50Hz/60Hz										
Capacity	Cooling	kW	1.7	2.2	2.8	3.6	4.5	5.0	5.6	6.3	7.1	
		Btu/h	5,800	7,500	9,600	12,300	15,300	17,100	19,100	21,500	24,200	
	Heating	kW	1.9	2.5	3.2	4.0	5.0	5.6	6.3	7.1	8.0	
		Btu/h	6,500	8,500	11,300	13,600	17,100	19,100	21,500	24,200	27,300	
Power Input	Cooling	W	35	35	64	64	65	65	60	100	100	
	Heating	W	35	35	64	64	65	65	60	100	100	
Sound Pressure		dB(A)	28/27/26/ 24/23/21	28/27/26/ 24/23/21	35/32/32/ 30/26/23	35/32/32/ 30/26/23	35/32/32/ 30/26/23	35/32/32/ 30/26/23	35/32/30/ 28/25/23	38/36/35/ 33/31/24	38/36/35/ 33/31/24	
Airflow Rate		L/s	117/108/102/ 95/88/80	117/108/102/ 95/88/80	150/135/122/ 112/98/87	150/135/122/ 112/98/87	200/180/157/ 135/113/92	200/180/157/ 135/113/92	225/208/187/ 167/147/128	300/268/238/ 205/175/145	300/268/238/ 205/175/145	
External Static Pressure		Pa	10(0-10-30)									
Piping	Connection Type	-	Flare-nut Connection(With Flare Nuts)									
	Liquid	mm	ϕ 6.35			ϕ 6.35	ϕ 9.53	ϕ 9.53				
		in.	1/4			1/4	3/8	3/8				
	Gas	mm	ϕ 12.7			ϕ 15.88	ϕ 15.88	ϕ 15.88				
		in.	1/2			5/8	5/8	5/8				
Condensate Drain	mm	I.D.32										
Weight	Net Weight	kg	16	16	17	17	20	20	24	24	24	
	Gross Weight	kg	19	19	20	20	24	24	29	29	29	
Dimensions	External (H×W×D)	mm	192×700×447			192×910×447		192×1180×447				
	Packaging (H×W×D)	mm	270×925×574			270×1136×574		270×1406×574				

NOTES: 1.The nominal cooling capacity and heating capacity are based on the following conditions:
 Cooling Operation Conditions
 Indoor Air Inlet Temperature: 27°C DB(80°F DB), 19.0°CWB(66.2°F WB)
 Outdoor Air Inlet Temperature: 35°C DB(95°F DB)
 Piping Length: 7.5 Meters Piping Lift: 0 Meter

Heating Operation Conditions
 Indoor Air Inlet Temperature: 20°C DB(68°F DB).
 Outdoor Air Inlet Temperature: 7°C DB(45°F DB), 6°C WB(43°F WB)

2.The sound pressure level is based on the following conditions: 1.5m beneath the unit.
 The above data was measured in an anechoic chamber so that the reflected sound should be taken into consideration in the field.

Indoor Unit

Ceiling Ducted Type

- High Static Pressure

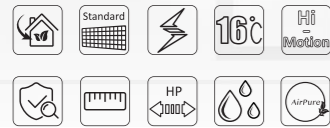

Model		AVD-07	AVD-09	AVD-12	AVD-15	AVD-19	AVD-22	AVD-24	AVD-27	AVD-30	AVD-38	AVD-48	AVD-54	AVD-76	AVD-96		
		HCFC	HCFC	HCFC	HCFC	HCFC	HCFC	HCFC	HCFC	HCFC	HCFC	HCFC	HCFC	UX6SEH*1	UX6SFL*1		
Power Supply		AC 1φ, 220V-240V/50Hz												AC 3φ, 380-415V/50Hz			
Capacity	Cooling	kW	2.2	2.8	3.6	4.5	5.6	6.3	7.1	8.0	9.0	11.2	14.0	16.0	22.4	28.0	
		Btu/h	7,500	9,600	12,300	15,400	19,100	21,600	24,200	27,400	30,800	38,000	48,000	54,500	76,500	95,600	
Capacity	Heating	kW	2.5	3.2	4.0	5.0	6.3	6.5	7.3	8.7	9.3	11.6	16.0	18.0	25.0	31.5	
		Btu/h	8,500	10,900	13,700	17,100	21,600	22,200	25,000	29,600	31,800	39,500	54,500	61,500	85,300	107,500	
Power Input	Cooling	W	100	100	130	130	140	190	190	250	250	250	340	430	1030	1280	
	Heating	W	100	100	130	130	140	190	190	250	250	250	340	430	1030	1280	
Sound Pressure		dB(A)	32/27/25	32/27/25	35/32/26	35/32/26	36/35/30	39/32/25	39/32/25	42/39/34	42/39/34	42/39/34	43/40/35	46/40/35	52	54	
Airflow Rate Under (50Pa)		L/s	185/150/97		212/200/160		272/250/200		347/317/212		542/517/458		663/635/42		767/717/567	967	1292
External Static Pressure		Pa	50(80)	50(80)	50(80)	50(80)	50(80)	50(80)	50(80)	50(80)	120(90)	120(90)	120(90)	120(90)	220	220	
Piping	Connection Type	-	Flare-nut Connection(With Flare Nuts)										Brazing				
	Liquid	mm	φ 6.35	φ 6.35	φ 6.35	φ 6.35	φ 6.35	φ 9.53	φ 9.53	φ 9.53	φ 9.53	φ 9.53	φ 9.53	φ 9.53	φ 9.53	φ 9.53	φ 9.53
		in.	1/4	1/4	1/4	1/4	1/4	3/8	3/8	3/8	3/8	3/8	3/8	3/8	3/8	3/8	3/8
	Gas	mm	φ 12.7	φ 12.7	φ 12.7	φ 12.7	φ 15.88	φ 15.88	φ 15.88	φ 15.88	φ 15.88	φ 15.88	φ 15.88	φ 15.88	φ 19.05	φ 22.2	
in.		1/2	1/2	1/2	1/2	5/8	5/8	5/8	5/8	5/8	5/8	5/8	5/8	3/4	7/8		
Condensate Drain		mm	I.D.32														
Weight	Net Weight	kg	25	25	25	25	30	30	30	45	45	45	53	53	94	106	
	Gross Weight	kg	30	30	30	30	38	38	38	52	52	52	59	69	106	111	
Dimensions	External (H×W×D)	mm	270×(650+75)×720			270×(900+75)×720			300×(1100+75)×800			300×(1400+75)×800			470×1060×1120	470×1250×1120	
	Packaging (H×W×D)	mm	385×895×870			385×1140×870			415×1345×950			415×1640×950			1345×1276×546	1345×1466×546	

NOTES: 1.The nominal cooling capacity and heating capacity are based on the following conditions:
Cooling Operation Conditions
Indoor Air Inlet Temperature: 27°C DB(80°F DB), 19.0°C WB(66.2°F WB)
Outdoor Air Inlet Temperature: 35°C DB(95°F DB)
Piping Length: 7.5 Meters Piping Lift: 0 Meter
Heating Operation Conditions
Indoor Air Inlet Temperature: 20°C DB(68°F DB)
Outdoor Air Inlet Temperature: 7°C DB(45°F DB), 6°C WB(43°F WB)

2. The sound pressure level is based on the following conditions: 1.5m beneath the unit.
With discharge duct (2.0m) and return duct(1.0m)
The above data was measured in an anechoic chamber so that the reflected sound should be taken into consideration in the field.

3. When bottom air inlet is adopted, the sound pressure will increase according to factors such as installation mode and the room structure.
*1: AC 3φ, 380V/50Hz

Indoor Unit

Ceiling Ducted Type

- Low Static Pressure

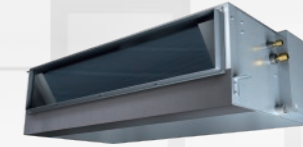
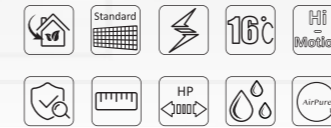

Model		AVD-07	AVD-09	AVD-12	AVD-15	AVD-19	AVD-22	AVD-24	AVD-27	AVD-30	AVD-38	AVD-48	AVD-54	AVD-76	AVD-96		
		HCFC	HCFC	HCFC	HCFC	HCFC	HCFC	HCFC	HCFC	HCFC	HCFC	HCFC	HCFC	UX6SEH*1	UX6SFL*1		
Power Supply		AC 1φ, 220V-240V/50Hz												AC 3φ, 380-415V/50Hz			
Capacity	Cooling	kW	2.2	2.8	3.6	4.5	5.6	6.3	7.1	8.0	9.0	11.2	14.0	16.0	22.4	28.0	
		Btu/h	7,500	9,600	12,300	15,400	19,100	21,600	24,200	27,400	30,800	38,000	48,000	54,500	76,500	95,600	
Capacity	Heating	kW	2.5	3.2	4.0	5.0	6.3	6.5	7.3	8.7	9.3	11.6	14.5	16.5	25.0	31.5	
		Btu/h	8,500	10,900	13,700	17,100	21,600	22,200	25,000	29,600	31,800	39,500	49,500	56,500	85,300	107,500	
Power Input	Cooling	W	60	60	110	110	90	160	160	240	240	240	290	360	950	1120	
	Heating	W	60	60	110	110	90	160	160	240	240	240	290	360	950	1120	
Sound Pressure		dB(A)	27/23/21	27/23/21	34/30/25	34/30/25	32/30/26	35/28/24	35/28/24	38/33/30	38/33/30	38/33/30	41/38/33	44/39/33	50	52	
Airflow Rate		L/s	150/117/100		200/167/142		250/217/167		317/233/167		467/400/325		592/483/400		650/517/400	967	1200
External Static Pressure		Pa	30	30	30	30	30	30	30	60	60	60	60	60	100	100	
Piping	Connection Type	-	Flare-nut Connection(With Flare Nuts)										Brazing				
	Liquid	mm	φ 6.35	φ 6.35	φ 6.35	φ 6.35	φ 6.35	φ 9.53	φ 9.53	φ 9.53	φ 9.53	φ 9.53	φ 9.53	φ 9.53	φ 9.53	φ 9.53	
		in.	1/4	1/4	1/4	1/4	1/4	3/8	3/8	3/8	3/8	3/8	3/8	3/8	3/8	3/8	
	Gas	mm	φ 12.7	φ 12.7	φ 12.7	φ 12.7	φ 15.88	φ 15.88	φ 15.88	φ 15.88	φ 15.88	φ 15.88	φ 15.88	φ 19.05	φ 19.05	φ 22.2	
in.		1/2	1/2	1/2	1/2	5/8	5/8	5/8	5/8	5/8	5/8	5/8	3/4	3/4	7/8		
Condensate Drain		mm	I.D.32														
Weight	Net Weight	kg	25	25	25	25	30	30	30	45	45	45	53	53	94	106	
	Gross Weight	kg	31	31	31	31	36	37	37	52	52	52	61	61	106	111	
Dimensions	External (H×W×D)	mm	270×(650+75)×720			270×(900+75)×720			300×(1100+75)×800			300×(1400+75)×800			470×1060×1120	470×1250×1120	
	Packaging (H×W×D)	mm	385×895×870			385×1140×870			415×1345×950			415×1640×950			546×1276×1345	546×1466×1345	

NOTES: 1.The nominal cooling capacity and heating capacity are based on the following conditions:
Cooling Operation Conditions
Indoor Air Inlet Temperature: 27°C DB(80°F DB), 19.0°C WB(66.2°F WB)
Outdoor Air Inlet Temperature: 35°C DB(95°F DB)
Piping Length: 7.5 Meters Piping Lift: 0 Meter
Heating Operation Conditions
Indoor Air Inlet Temperature: 20°C DB(68°F DB)
Outdoor Air Inlet Temperature: 7°C DB(45°F DB), 6°C WB(43°F WB)

2. The sound pressure level is based on the following conditions: 1.5m beneath the unit.
With discharge duct (2.0m) and return duct(1.0m)
The above data was measured in an anechoic chamber so that the reflected sound should be taken into consideration in the field.

3. When bottom air inlet is adopted, the sound pressure will increase according to factors such as installation mode and the room structure.
*1: AC 3φ, 380V/50Hz

Indoor Unit



Indoor Unit

1-WAY CASSETTE TYPE

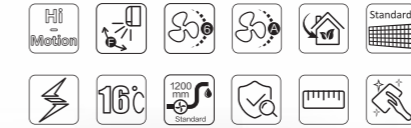

Convenient Installation

Customers can choose the installation method according to different situation. The concise fashion elements style is suitable for renewal projects and un-decorated shopping malls or classrooms.

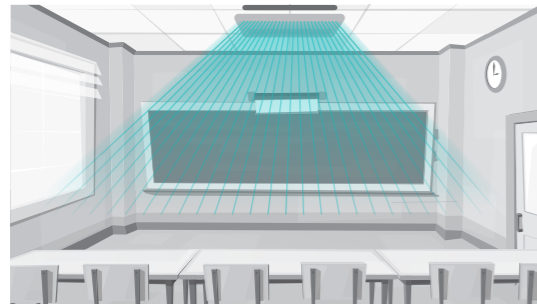

Wider 3D-Airflow Range

Broad air deflector design realizes broad air supply range. The wind direction can be adjusted according to the need thus it can make the customers feel more comfortable.

NOTE: This function can be achieved by the wired controller: HYXE-J01H, HYXE-VA01A, HYXM-VB01A, HYXE-VC01

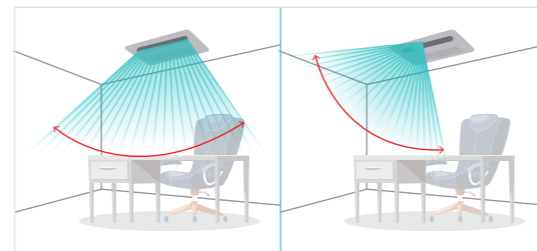

Efficiency DC Motor, Adjustable Air Speed

Adoption of the efficient DC motor and the optimized duct design assure the smooth air flow.

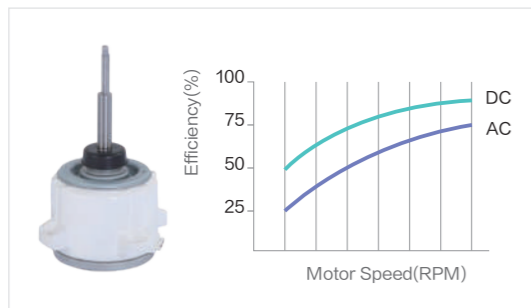

Standard Equipped Drain Pump

Standard equipped drain pump with the maximum drainage height up to 1200mm.

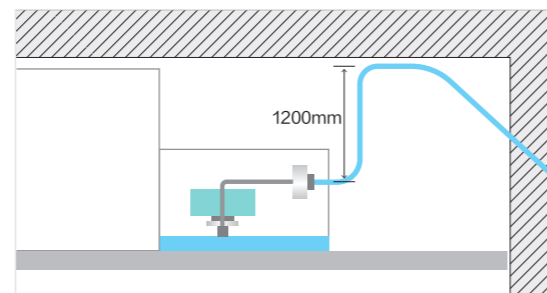

Model		AVY-07UXJSJA	AVY-09UXJSJA	AVY-12UXJSJA	AVY-14UXJSJA	AVY-18UXJSKA	AVY-24UXJSKA	
Power Supply		AC 1ϕ, 220-240V/50Hz/60Hz						
Capacity	Cooling	kW	2.2	2.8	3.6	4.0	5.6	7.1
		Btu/h	7,500	9,600	12,300	13,600	19,100	24,200
Power Input	Heating	kW	2.5	3.2	4.0	4.5	6.3	8.0
		Btu/h	8,500	10,900	13,600	15,400	21,500	27,300
Power Input	Cooling	W	14	14	24	34	34	74
	Heating	W	14	24	34	44	44	94
Sound Pressure	dB(A)	33/32/31/30/29/28	35/34/32/31/29/28	40/36/35/33/30/29	40/36/35/33/30/29	41/39/36/35/33/31	48/46/43/40/37/33	
Airflow Rate	L/s	103/98/93/85/80/77	110/103/93/85/80/77	138/122/113/103/93/85	138/122/113/103/93/85	202/165/147/137/130/110	260/210/187/165/140/118	
		Flare-nut Connection(With Flare Nuts)						
Piping	Connection Type	-						
	Liquid	mm	ϕ6.35	ϕ6.35	ϕ6.35	ϕ6.35	ϕ6.35	ϕ9.53
		in.	1/4	1/4	1/4	1/4	1/4	3/8
	Gas	mm	ϕ12.7	ϕ12.7	ϕ12.7	ϕ12.7	ϕ15.88	ϕ15.88
in.		1/2	1/2	1/2	1/2	5/8	5/8	
Condensate Drain	mm	I.D.32						
Weight	Net Weight	kg	19	19	20	20	24	24
	Gross Weight	kg	23	23	24	24	29	29
Dimensions	External (H×W×D)	mm	192×910×470				192×1180×470	
	Packaging (H×W×D)	mm	268×1136×574				268×1406×574	
		mm						
Panel	Model	-	HP-D-NA			HP-E-NA		
	Panel Colour	-	Neutral White					
	Body Dimensions (H×W×D)	mm	55×1100×550				55×1370×550	
	Packaging Dimensions (H×W×D)	mm	130×1160×610				130×1430×610	
	Net Weight	kg	5				6	
	Gross Weight	kg	8				10	

NOTES: 1. The nominal cooling capacity is based on the following conditions:
Indoor Air Inlet Temperature: 27°C DB (80°F DB), 19.0°C WB(66.2°F WB)
Outdoor Air Inlet Temperature: 35°C DB(95°F DB)
Piping Length: 7.5 Meters Piping Lift: 0 Meter

2. The sound pressure level is based on the following conditions:
1.0m beneath the unit, 1.0m from Discharge Grille. The above data was measured in an anechoic chamber so that the reflected sound should be taken into consideration in the field. When bottom air inlet is adopted, the sound pressure will increase according to factors such as installation mode and the room structure.

Indoor Unit

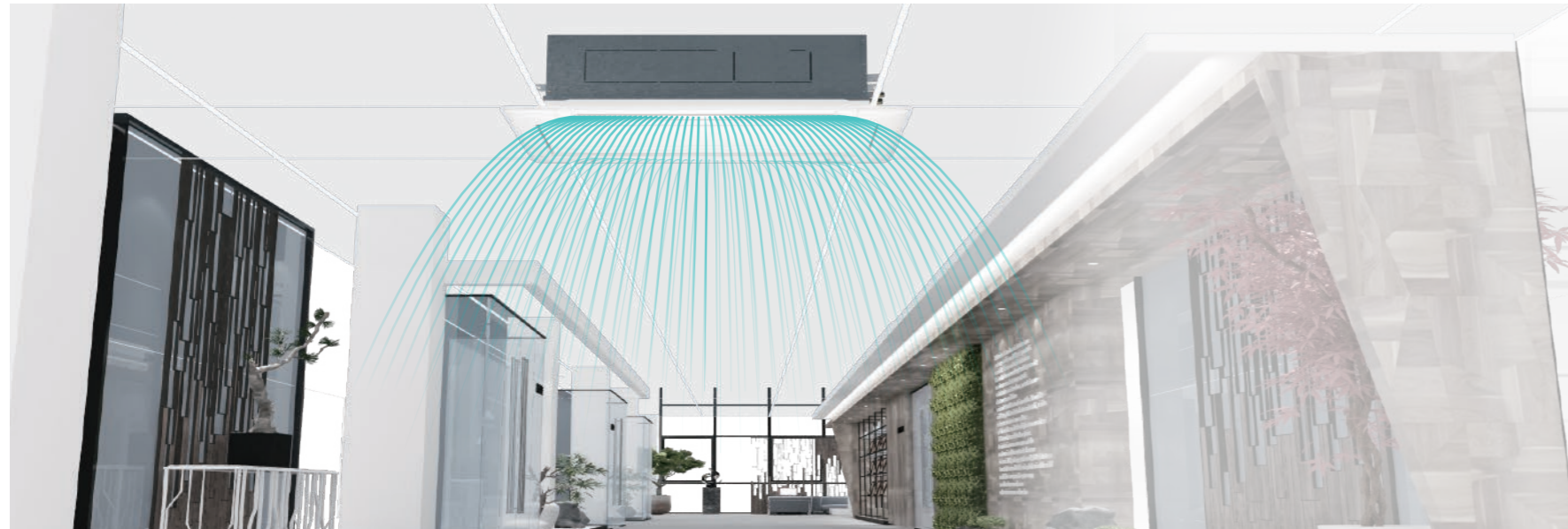

Indoor Unit

2-way Cassette Type



2-Way Individual Louver

The newly equipped individual louver setting function allows the angles of the 2 louvers to be adjusted individually.

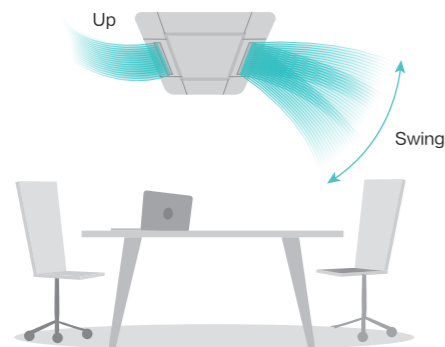

Space Saving

The slim structure of the cassette having height as low as 298mm can be installed in ceiling spaces with a minimum of 310mm. Narrow corridors or zoned spaces are best fitted with 2 way cassettes due to its compact design having 1.42m.

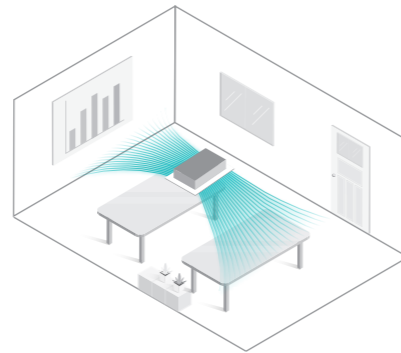

Efficiency DC Motor, Adjustable Air Speed

Adoption of the efficient DC motor and the optimized duct design assure the smooth air flow.

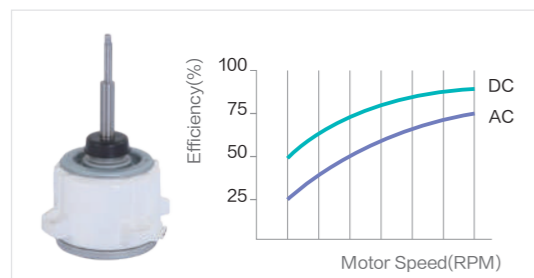

Standard Equipped Drain Pump

Standard equipped drain pump with the maximum drainage height up to 1200mm.

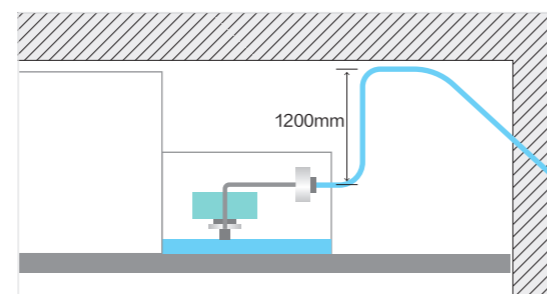

Model		AVL-07 UXJSGA	AVL-09 UXJSGA	AVL-12 UXJSGA	AVL-14 UXJSGA	AVL-18 UXJSGA	AVL-24 UXJSGA	AVL-27 UXJSGA	AVL-30 UXJSGA	AVL-38 UXJSHA	AVL-48 UXJSHA	AVL-54 UXJSHA		
Power Supply		AC 1φ, 220-240V/50Hz/60Hz												
Capacity	Cooling	kW	2.2	2.8	3.6	4.3	5.6	7.1	8.4	9.0	11.2	14.0	16.0	
		Btu/h	7,500	9,600	12,300	14,700	19,100	24,200	28,700	30,700	38,200	47,800	54,600	
Power Input	Heating	kW	2.8	3.3	4.0	4.9	6.5	8.0	9.0	10.0	13.0	16.0	18.0	
		Btu/h	9,600	11,300	13,600	16,700	22,200	27,300	30,700	34,100	44,400	54,600	61,400	
Power Input	Cooling	W	14	14	14	24	34	44	64	74	84	104	114	
	Heating	W	14	14	14	24	34	44	64	74	84	104	114	
Sound Pressure		dB(A)	32/30/	33/30/	34/31/	40/37/	42/39/	45/42/	47/44/	49/46/	46/44/	48/45/	49/46/	
			29/27	29/28	30/28	34/32	36/33	40/36	40/36	42/37	40/38	42/38	43/40	
Airflow Rate		L/s	167/142/	183/157/	200/175/	250/220/	283/248/	317/273/	350/307/	367/322/	500/440/	583/513/	617/542/	
			120/100	137/110	148/125	192/165	217/187	238/205	260/210	272/218	385/330	448/352	473/402	
Piping	Connection Type		Flare-nut Connection(With Flare Nuts)											
	Liquid	mm	φ6.35	φ6.35	φ6.35	φ6.35	φ6.35	φ9.53	φ9.53	φ9.53	φ9.53	φ9.53	φ9.53	
		in.	1/4	1/4	1/4	1/4	1/4	3/8	3/8	3/8	3/8	3/8	3/8	
	Gas	mm	φ12.7	φ12.7	φ12.7	φ12.7	φ15.88	φ15.88	φ15.88	φ15.88	φ15.88	φ15.88	φ15.88	
in.		1/2	1/2	1/2	1/2	5/8	5/8	5/8	5/8	5/8	5/8	5/8		
Condensate Drain		mm	I.D.32											
Weight	Net Weight	kg	22	22	22	24	24	24	24	24	39	39	39	
	Gross Weight	kg	28	28	28	30	30	30	30	30	47	47	47	
Dimensions	External (H×W×D)	mm	298×860×630						298×1420×630					
	Packaging (H×W×D)	mm	350×1070×710						350×1630×710					
Panel	Model	-	HP-C-NA						HP-F-NA					
	Panel Colour	-	Neutral White											
	Body Dimensions (H×W×D)	mm	30×1100×710						30×1660×710					
	Packaging Dimensions (H×W×D)	mm	160×1170×740						160×1710×740					
	Net Weight	kg	7.5						10.5					
	Gross Weight	kg	13.3						17.8					

NOTES: 1. The nominal cooling capacity is based on the following conditions:
Indoor Air Inlet Temperature: 27°C DB (80°F DB), 19.0°C WB(66.2°F WB)
Outdoor Air Inlet Temperature: 35°C DB(95°F DB)
Piping Length: 7.5 Meters Piping Lift: 0 Meter.

2. The sound pressure level is based on the following conditions: 1.5m beneath the unit.
The above data was measured in an anechoic chamber so that the reflected sound should be taken into consideration in the field.

Indoor Unit



Console Type



3D Air Supply/Return

Heating Mode
When the temperature of air return exceeds 20°C, the upper air deflector will close automatically. When the temperature of air return is below 18°C, the upper air deflector will open automatically.

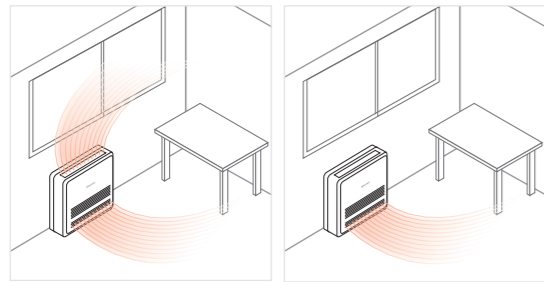

*Note: During heating mode, when the inlet air temperature of indoor unit is higher than 20°C, the upper air louver will automatically close, and when the inlet air temperature of indoor unit is lower than 18°C, the upper air louver will automatically open.

Cooling Mode
After running one hour in cooling mode, the air deflector below will close automatically.

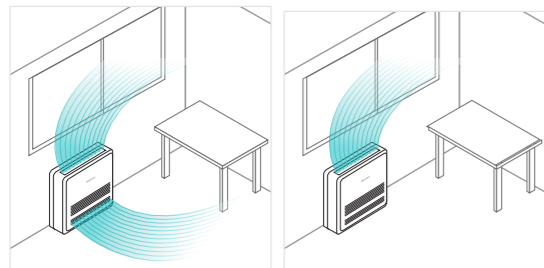

*Note: During cooling mode, the lower air louver will close automatically after the indoor unit operates in low fan speed mode for an hour. Otherwise it will keep open.

Stylish Aesthetics

With LED and temperature display, console unit is an upgraded stylish air-conditioning option to the customers. Be suitable for any residential or commercial applications needed a unit near the floor for effective heating during the winter and cooling during summer.



Connected with Hi-Motion(Optional)

The unit can be controlled automatically through the Hi-Motion (optional).

NOTE: This function can be achieved by the wired controller: HYXE-J01H, HYXM-VB01A

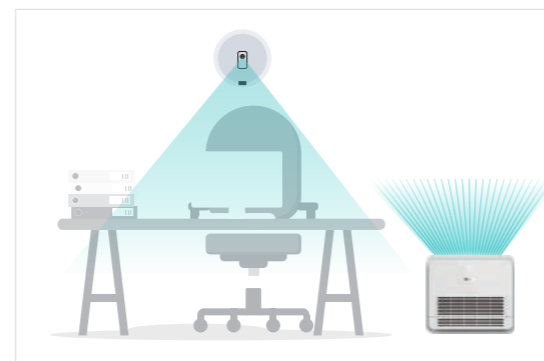

Indoor Unit

Model		AVK-05HJFCAA	AVK-07HJFCAA	AVK-09HJFCAA	AVK-12HJFCAA	AVK-15HJFCAA	AVK-17HJFCAA	
Power Supply		AC 1Φ, 220V~240V/50Hz/60Hz						
Capacity	Cooling	kW	1.5	2.2	2.8	3.6	4.5	5.0
		Btu/h	5,100	7,500	9,600	12,300	15,300	17,100
Capacity	Heating	kW	2.0	2.5	3.3	4.2	5.0	5.6
		Btu/h	6,800	8,500	11,200	14,300	17,000	19,100
Power Input	Cooling	W	10	11	12	14	18	23
	Heating	W	10	11	12	14	18	23
Sound Pressure	dB(A)	32/30/29/28/26/24	34/32/31/29/27/26	36/35/32/31/29/27	39/36/34/31/29/27	41/39/37/35/33/32	44/43/41/39/37/36	
Airflow Rate	L/s	100/95/88/	123/117/107/	133/123/117/	137/127/113/	150/142/130/	168/162/150/	
		85/78/75	100/93/88	107/100/93	103/95/88	120/110/107	142/132/122	
Panel Colour	-	Pure White						
Piping	Connection Type	Flare-nut Connection(With Flare Nuts)						
	Liquid	mm	Φ 6.35					
		in.	1/4					
	Gas	mm	Φ 12.7					
in.		1/2						
Condensate Drain	mm	O.D.18						
Weight	Net Weight	kg	16.1			17.4		
	Gross Weight	kg	21.1			22.4		
Dimensions	External (H×W×D)	mm	630×700×225					
	Packaging (H×W×D)	mm	725×790×315					

NOTES: 1.The nominal cooling capacity and heating capacity are based on following conditions:
Cooling Operation Conditions
Indoor Air Inlet Temperature: 27°CDB(80°F DB), 19.0°CWB(66.2°F WB)
Outdoor Air Inlet Temperature: 35°CDB(95°F DB)
Piping Length: 7.5 Meters Piping Lift: 0 Meter
Heating Operation Conditions
Indoor Air Inlet Temperature: 20°CDB(68°F DB)
Outdoor Air Inlet Temperature: 7°CDB(45°F DB), 6°CWB(43°F WB)

2.The sound pressure level is based on following conditions:
It is measured in anechoic room. Operation noise differs with operation and ambient conditions.
Location of Microphone:

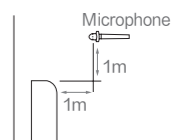



High-efficiency DC Fan Motor

The power consumption of the unit with DC fan motor can be reduced greatly in comparison to the old AC product. The minimum power consumption is only 20W, which is reduced by 60%. It can achieve low-cost operation.

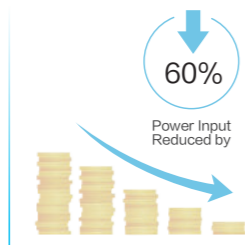

6 Fan Speed

6 indoor fan speeds are available to meet the needs of different indoor conditions.

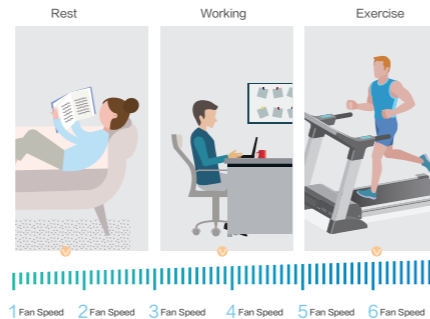

Optimal Noise Control

The low-noise DC fan motor and the enhanced vibration pad on the distribution pipe and EEV will ensure a quieter operation. Besides, with Hisense special smart noise reduction technology, the operation noise can also be decreased effectively. During the high airflow operation, maximum 5dB(A)* is decreased compare with the previous generation. What's more, sleep mode and quiet mode are also available for users to further enjoy a quiet environment.

Take AVS-12 as an example

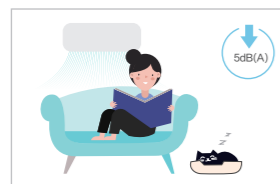

Self-cleaning Function

Featured with self-cleaning technology, the evaporator can be self-cleaned automatically just with the tap of a button in the controller, which is very convenient and saves the cost of manual cleaning, while ensuring a clean environment.

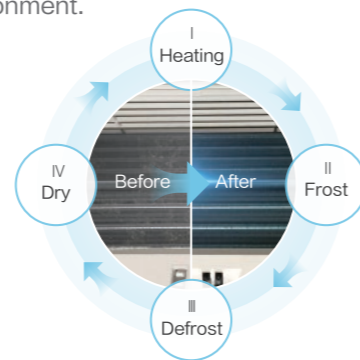

4 processes for deep cleaning

Model		AVS-05 HJFTDD	AVS-07 HJFTDD	AVS-09 HJFTDD	AVS-12 HJFTDD	AVS-15 HJFTDD	AVS-18 HJFTDD	AVS-24 HJFTDD	AVS-28 HJFTDD	
Power Supply		AC 1 ϕ , 220-240V/50Hz; AC 1 ϕ , 220V/60Hz								
Capacity	Cooling	kW	1.7	2.2	2.8	3.6	4.5	5.6	7.1	8.4
		Btu/h	5,800	7,500	9,600	12,300	15,400	19,100	24,200	28,700
	Heating	kW	2.0	2.5	3.3	4.0	5.0	6.3	8.0	8.4
		Btu/h	6,500	8,500	11,300	13,700	17,100	21,500	27,300	28,700
Power Input	Cooling	W	20	20	20	30	20	30	50	80
	Heating	W	20	20	20	30	30	30	70	80
Sound Pressure	dB(A)	33/32/32/ 30/30/28	36/35/33/ 32/30/28	36/35/33/ 32/30/28	38/35/33/ 32/30/28	38/37/36/ 32/31/29	40/38/36/ 35/33/31	45/42/41/ 38/35/31	50/48/45/ 41/36/33	
Airflow Rate	m ³ /h	520/500/490/ 450/430/420	590/550/520/ 490/450/420	590/550/520/ 490/450/420	620/550/520/ 490/450/420	690/660/620/ 540/520/480	970/900/850/ 800/730/690	1200/1080/1020/ 900/800/700	1400/1320/1200/ 1020/850/730	
Piping	Connection Type		Flare Nuts							
	Liquid	mm	ϕ 6.35	ϕ 6.35	ϕ 6.35	ϕ 6.35	ϕ 6.35	ϕ 9.53	ϕ 9.53	ϕ 9.53
		inch	1/4	1/4	1/4	1/4	1/4	3/8	3/8	3/8
	Gas	mm	ϕ 9.53	ϕ 9.53	ϕ 9.53	ϕ 9.53	ϕ 12.7	ϕ 15.88	ϕ 15.88	ϕ 15.88
inch		3/8	3/8	3/8	3/8	1/2	5/8	5/8	5/8	
Drain Pipe	mm	O.D.18								
Weight	Net Weight	kg	9	9	9	9	13	14.5	14.5	14.5
	Gross Weight	kg	12.5	12.5	12.5	12.5	17	19	19	19
Dimensions	External	Hmm	270				315		315	
		Wmm	845				960		1120	
		Dmm	203				230		230	
	Packaging	Hmm	375				430		430	
		Wmm	943				1058		1223	
		Dmm	310				328		328	

NOTES:

1. The rated capacity is based on the following conditions:
Cooling conditions: indoor air inlet temperature: 27°C DB, 19°C WB, outdoor air inlet temperature: 35°C DB, pipe length: 7.5m, pipe height difference: 0m
Heating conditions: indoor air inlet temperature: 20°C DB, outdoor air inlet temperature: 7°C DB, 6°C WB, pipe length: 7.5m, pipe height difference: 0m

2. The above noise values are measured in an anechoic chamber so that reflected sound should be taken into consideration during actual operation.
The above noise values are measured under the fan mode operation, and measured at a point 1m in front of the unit and 0.8m below the unit.

Indoor Unit



Indoor Unit

Ceiling & Floor Type



Sleek Smooth Design

Shiny white cover panel of the unit has an streamlined elegant aesthetic. The bolts and nuts used to secure the unit onto wall or ceiling are designed to be concealed in the unit for a sleek room interior look.

Flexible Installation

The unit can be installed to be standing on floors or hanging on ceilings. Whereby interior walls maximized to display items, can hang the unit on the ceiling.



Hanging on the wall Standing on the floor

Convenient Installation and Maintenance

Adjust the ceiling or wall mounting height by just opening the side panels without the need to access the internal parts. Service manholes are unnecessary due to the strategic repositioning of piping connections and electrical box behind the air return panel, service and clean the filter all in the same compartment.

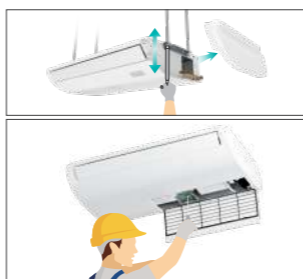

3D Air Supply

Louvers are consist of horizontal and vertical flaps to cover larger coverage area to the edges of any rooms. Wider opening angle from up to 120° for vertical louvers and up to 71° for horizontal louvers supply air further and lower down to floor needed during heating modes.

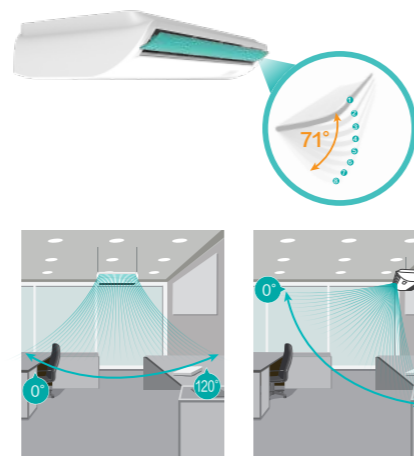

Model		AVV-17URSCA	AVV-18URSCA	AVV-22URSCA	AVV-24URSCA	AVV-27URSCB	AVV-30URSCB	AVV-38URSCB	AVV-48URSCC		
Power Supply		AC 1ϕ, 220V~240V/50Hz/60Hz									
Capacity	Cooling	kW	5.0	5.6	6.3	7.1	8.4	9.0	11.2	14.2	
		Btu/h	17,100	19,100	21,500	24,200	28,700	30,700	38,200	48,500	
Power Input	Heating	kW	5.6	6.5	7.5	8.5	9.6	10.0	13.0	16.3	
		Btu/h	19,100	22,200	25,600	29,000	32,800	34,100	44,400	55,600	
Sound Pressure	Cooling	W	40	40	70	70	70	80	130	160	
	Heating	W	40	40	70	70	70	80	130	160	
Sound Pressure	Ceiling	dB(A)	39/35/30	39/35/30	45/41/37	45/41/37	43/39/34	45/40/36	51/46/40	50/46/42	
	Floor	dB(A)	43/38/35	43/38/35	48/44/40	48/44/40	46/41/37	48/43/39	54/49/43	55/50/46	
Airflow Rate		L/s	217/183/150	217/183/150	268/233/188	268/233/188	303/253/203	323/272/222	413/342/272	550/467/383	
Speed-up Setting HH1		m³/min	14.2	14.2	17.8	17.8	19.8	21.2	27.0	36.0	
Speed-up Setting HH2		m³/min	16.0	16.0	20.0	20.0	22.3	23.5	29.2	37.4	
Panel Colour		-	-	-	-	-	-	-	-	-	
Piping	Connection Type	-	Flare-nut Connection(With Flare Nuts)								
	Liquid	mm	ϕ 6.35				ϕ 9.53				
		in.	1/4				3/8				
	Gas	mm	ϕ 15.88				ϕ 15.88				
in.		5/8				5/8					
Condensate Drain		mm	I.D.32								
Weight	Net Weight	kg	31	31	32	32	39	40	41	47	
	Gross Weight	kg	38	38	39	39	46	47	48	56	
Dimensions	External (H×W×D)	mm	230×990×680				230×1285×680			230×1580×680	
	Packaging (H×W×D)	mm	340×1110×830				340×1400×830			340×1690×830	

NOTES: 1.The nominal cooling capacity and heating capacity are based on the following conditions:
Cooling Operation Conditions
Indoor Air Inlet Temperature: 27°C DB(80°F DB), 19.0°C WB(66.2°F WB)
Outdoor Air Inlet Temperature: 35°C DB(95°F DB)
Piping Length: 7.5 Meters Piping Lift: 0 Meter

2. The sound pressure level is based on the following conditions:
1.0m beneath the unit, 1.0m from Discharge Grille.
The above data was measured in an anechoic chamber so that the reflected sound should be taken into consideration in the field. When bottom air inlet is adopted, sound pressure will increase according to factors such as installation mode and the room structure.

Heating Operation Conditions
Indoor Air Inlet Temperature: 20°C DB(68°F DB).
Outdoor Air Inlet Temperature: 7°C DB(45°F DB), 6°C WB(43°F WB)

Indoor Unit



Indoor Unit

Floor Concealed Type



Connectable Devices

Third party accessories like air return filters, fresh air introduction and humidity sensors are all connectable to the Floor Concealed Type.

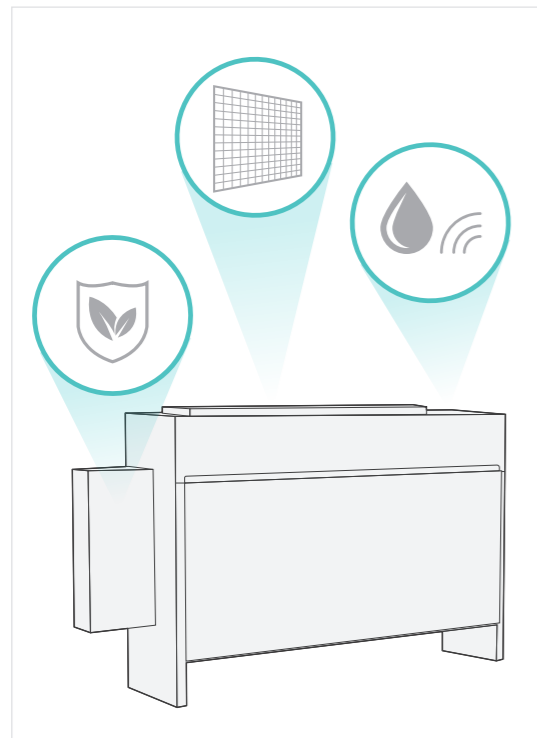

Space Saving

Floor Concealed Type is designed to be installed on floors completely concealed into the walls, which is slim and compact with only height of 620mm to be hidden under half-heighted windows.

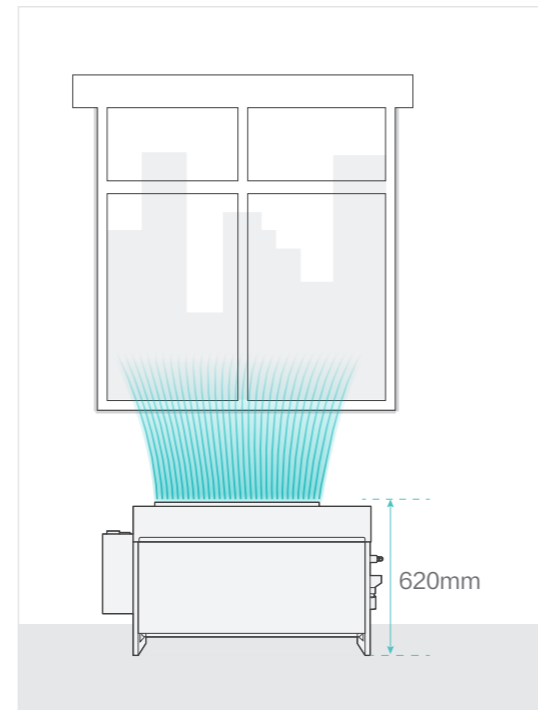

Model		AVH-09UXCSAA	AVH-14UXCSAA	AVH-18UXCSBA	AVH-24UXCSBA	
Power Supply		AC 1ϕ, 220~240V/50Hz				
Model		AVH-09UX2SAA	AVH-14UX2SAA	AVH-18UX2SBA	AVH-24UX2SBA	
Power Supply		AC 1ϕ, 220V/60Hz				
Capacity	Cooling	kW	2.8	4.3	5.6	7.1
		Btu/h	9,600	14,700	19,100	24,200
	Heating	kW	3.3	4.9	6.5	8.5
		Btu/h	11,300	16,700	22,200	29,000
Power Input	Cooling	W	50	80	90	120
	Heating	W	50	80	90	120
Sound Pressure		dB(A)	34/31/27	40/36/34	41/36/32	44/40/36
Airflow Rate		L/s	142/125/106	172/150/133	247/206/175	272/231/197
Piping	Connection Type		Flare-nut Connection(With Flare Nuts)			
	Liquid	mm	ϕ 6.35	ϕ 6.35	ϕ 6.35	ϕ 9.53
		in.	1/4	1/4	1/4	3/8
	Gas	mm	ϕ 12.7	ϕ 12.7	ϕ 15.88	ϕ 15.88
		in.	1/2	1/2	5/8	5/8
Condensate Drain		mm	I.D.32			
Weight	Net Weight	kg	18	22	26	27
	Gross Weight	kg	30	31	37	37
Dimensions	External (H×W×D)	mm	620 × (948+139) × 202		620 × (1218+139) × 202	
	Packaging (H×W×D)	mm	675 × 1160 × 240		675 × 1430 × 240	

NOTES: 1.The nominal cooling capacity and heating capacity are based on the following conditions:
Cooling Operation Conditions
Indoor Air Inlet Temperature: 27°C DB(80°F DB), 19.0°C WB(66.2°F WB)
Outdoor Air Inlet Temperature: 35°C DB(95°F DB)
Piping Length: 7.5 Meters Piping Lift: 0 Meter

2. The sound pressure level is based on the following conditions:
1.5m meters from the unit and 1.5m meters from floor level.
The above data was measured in an anechoic chamber so that reflected sound should be taken into consideration in the field.

Heating Operation Conditions
Indoor Air Inlet Temperature: 20°C DB(68°F DB).
Outdoor Air Inlet Temperature: 7°C DB(45°F DB), 6°C WB(43°F WB)

All Fresh Air Indoor Unit

Space Saving

Fresh air unit consisting of height of 370mm only requires small amount of ceiling space and fits into complicated kitchen ceilings with various exhaust duct connections.

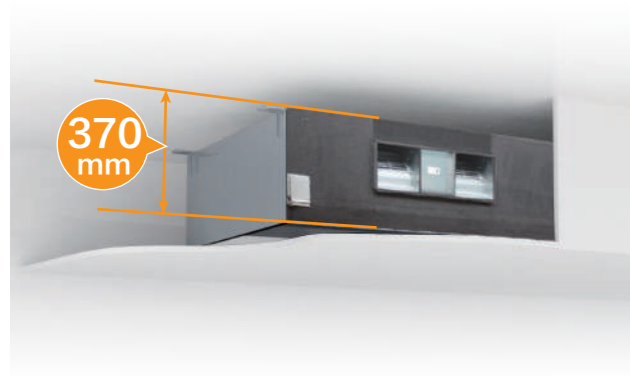

Larger Airflow Rate & Static Pressure Options

The total amount of fresh air units could be reduced with larger capacity, large airflow rate per unit. With the reduced amount of units, fresh air ducts often need to be supply to the furthest room. Hence achievable with high static pressures offered.

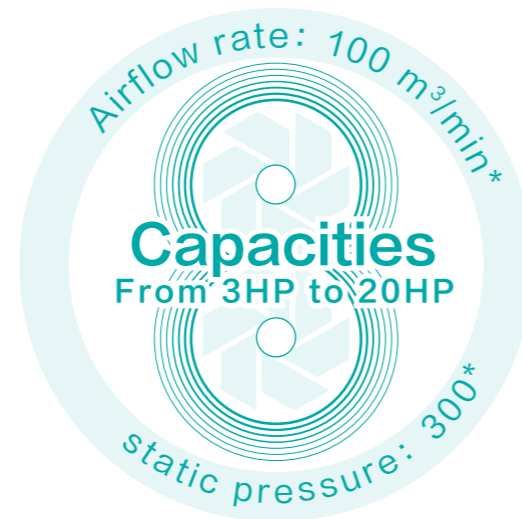

*Note: only specific model can reach this figure.

Simple & Flexible Piping System

Fresh air from the units could be pre-cooled connecting to the same refrigerant systems with other indoor units, introducing cooled or warm fresh air directly without overburdening other fan coil units.



All Fresh Air Indoor Unit

All Fresh Air Indoor Unit



Model		AVA-30UX CSCH-70	AVA-48UX CSQH-108	AVA-76UX CSRH-168	AVA-96UX CSRH-210	AVA-114UX 6SRH-300	AVA-154UX 6SSH-400	AVA-190UX 6STH-500	AVA-190UX 6STH-600		
Power Supply		AC 1 ϕ , 220V-240V/50Hz				AC 3 ϕ , 380V-415V/50Hz					
Model		AVA-30UX 2SCH-70	AVA-48UX 2SQH-108	AVA-76UX 2SRH-168	AVA-96UX 2SRH-210	-					
Power Supply		AC 1 ϕ , 220V/60Hz				-					
Capacity	Cooling	kW	9.0	14.0	22.4	28.0	33.5	45.0	56.0	56.0	
		Btu/h	30,700	47,800	76,500	95,600	114,300	153,600	191,100	191,100	
Power Input	Heating	kW	8.6	13.7	21.9	24.5	26.8	36.0	44.8	44.8	
		Btu/h	29,400	46,800	74,700	83,600	91,500	122,900	152,900	152,900	
Sound Pressure		dB(A)	32	43	45	46	56	61	64	66	
Airflow Rate		m ³ /min	11.0	18.0	28.0	35.0	50.0	66.7	83.3	100.0	
External Static Pressure		Pa	60(120)	200	220	220	220	300	320	300	
Piping	Liquid	mm	ϕ 9.53	ϕ 9.53	ϕ 9.53	ϕ 9.53	ϕ 12.70	ϕ 12.70	ϕ 15.88	ϕ 15.88	
		inch	3/8	3/8	3/8	3/8	1/2	1/2	5/8	5/8	
	Gas	mm	ϕ 15.88	ϕ 15.88	ϕ 19.05	ϕ 22.20	ϕ 25.40	ϕ 25.40	ϕ 28.60	ϕ 28.60	
		inch	5/8	5/8	3/4	7/8	1	1	1-1/8	1-1/8	
Condensate Drain		mm	I.D.32				RC1 (Internal Screw)				
Weight	Net Weight	kg	46	60	97	97	97	196	222	222	
	Gross Weight	kg	51	64	117	117	117	240	267	267	
Dimensions	External	H	mm	370	370	486	486	486	635	735	735
		W	mm	920	1320	1270	1270	1270	1950	1950	1950
		D	mm	800	800	1069	1069	1069	805	805	805
	Packaging	H	mm	390	390	1290	1290	1290	816	916	916
		W	mm	1112	1512	1466	1466	1466	2213	2213	2213
		D	mm	922	922	540	540	540	1006	1006	1006
Temperature Range of Fresh Air		-	Cooling: 20°C-43°C, Heating: -5°C-15°C								

Notes:

- The nominal cooling capacity and heating capacity are based on following conditions:
Cooling operation conditions: 33°C DB, 28°C WB, piping length: 7.5m, piping lift: 0m
Heating operation conditions: 0°C DB, -2.9°C WB, piping length: 7.5m, piping lift: 0m
(Heating capacity is tested when defrosting is not available)
- The sound pressure level is based on following conditions: 1.5m beneath the unit.
The above data was measured in an anechoic chamber so that reflected sound should be taken into consideration in the field.
- The unit shall be connected to the outdoor unit. In case of connecting the fresh air indoor unit with other types of indoor units in the same refrigerant system, please calculate the capacity of the unit as 46.1KBtu/h(30.7KBtu/h), 71.7KBtu/h(47.8KBtu/h), 143.3KBtu/h(95.6KBtu/h).
- When the outdoor unit is connected only with all fresh air indoor unit, the configuration rate is 100%.
- Under cooling mode, when outdoor temperature is lower than 20°C, the system will automatically shift to ventilation operation;
Under heating mode, when outdoor temperature is higher than 15°C the system will automatically shift to ventilation operation;
In case inlet temperature is below -5°C, all fresh air unit will stop.

Heat Recovery Ventilator

Hisense heat recovery ventilator adopts efficient convective transfer material to effectively recycle the heat losses due to ventilation, reduces the fresh air load, achieves the purpose of energy saving and lower running cost of air conditioning unit, fresh air is supplied to indoors continuously which can make your room more comfortable and healthy.

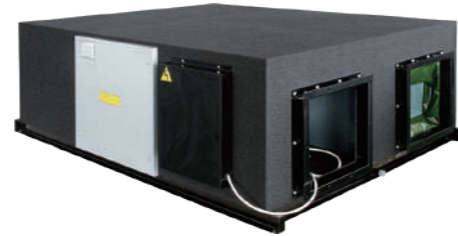

Basic Structure and Operation Principle

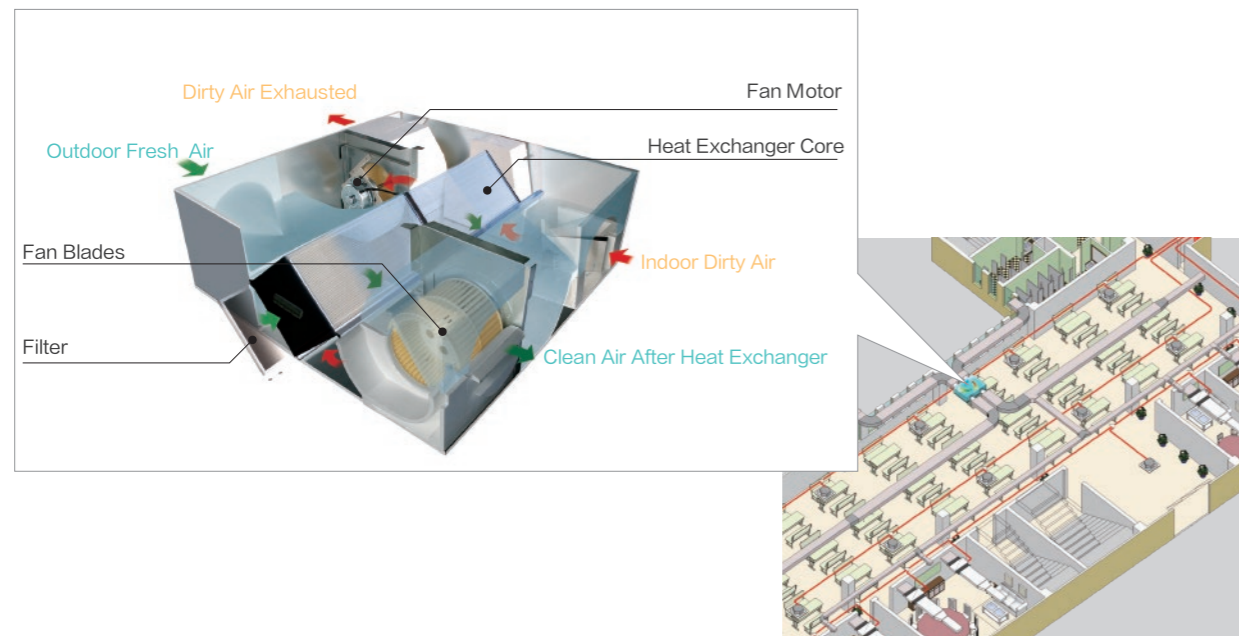

Airflow System



Heat Recovery Ventilator

Energy Saving Analysis

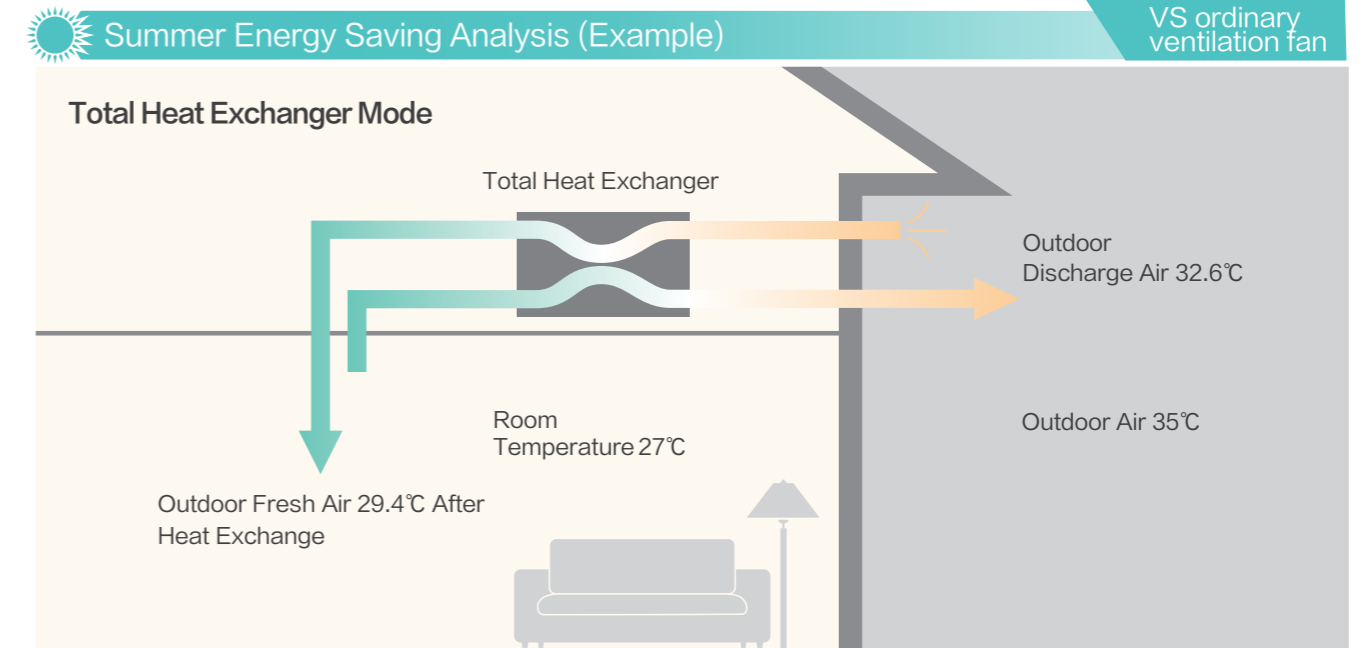

In summer, when the cold energy of 27°C air discharged from indoor pass through the heat exchanger, the 35°C outdoor hot air is pre-cooled to 29.4°C fresh air and supplied to indoors. As shown above, the air conditioner only needs to cool the air by 2.4°C to maintain a comfortable room temperature and fresh air. In this process, the discharge air pre-cools the fresh air by HRV, The temperature recovery efficiency in cooling is 70% max, and enthalpy exchange efficiency is 57% max.

	Total Heat Exchanger	Traditional Ventilation Fan
Dry Bulb Temperature/°C	29.4	35
Wet Bulb Temperature/°C	23.3	28
Moisture Content g/kg	15.7	21.1
Relative Humidity %	60.1	59.1
Enthalpy Value kJ/kg(DA)	69.8	89.4
Recycling Cold kW	1.57	0
Heat Load kW	2.8	2.8

Air inlet	Outdoor Air
Dry Bulb Temperature/°C	35
Wet Bulb Temperature/°C	28
Relative Humidity %	59.1
Enthalpy Value kJ/kg(DA)	89.4

Air inlet	Indoor Air	Discharge Air
Dry Bulb Temperature/°C	27	32.6
Wet Bulb Temperature/°C	19.5	28
Relative Humidity %	49.8	59.1
Enthalpy Value kJ/kg(DA)	55.5	89.4

Very Low Noise

Through a low-noise fan motor, advanced internal silence insulation device and optimization of air passage, the units have low noise. The minimum operating sound is only 28dB(A), which will not affect the users' sleep and rest at all.

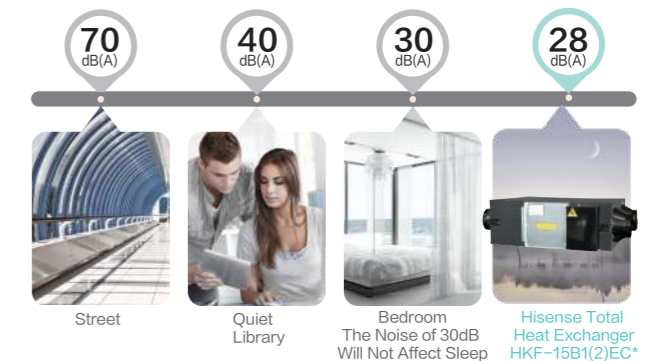

Heat Recovery Ventilator

With Flexible Control, It Has Access to Centralized Control of Hisense Air Conditioning System

HYXE-VC01

Features:

- Max. connectable indoor units: 6
- LCD display with back light
- Touch button
- Flat back-cover for easy mounting



Main Functions

- Cooling/Heating/Auto
- Dehumidification
- Fan speed
- Operation monitoring
- 24-hour timer
- Main-sub control
- Check function
- Air filter cleaning reminding
- Error code history display
- Auto test run
- Indoor/Outdoor PCB checking
- Self diagnostic function
- Back light
- Built-in temperature sensor
- Wireless control available
- Individual louver control
- Breeze mode
- Health(AirPure)
- ECO(energy saving)
- Quiet
- Sleep
- Window contact design
- 3D-Air flow
- Self-cleaning

Centralized Control System

Hisense centralized control type total heat exchanger products can be connected to the centralized control system of Hisense air conditioning* and achieve the linkage with air conditioning system and centralized control, so the operation is more convenient and more intelligent!

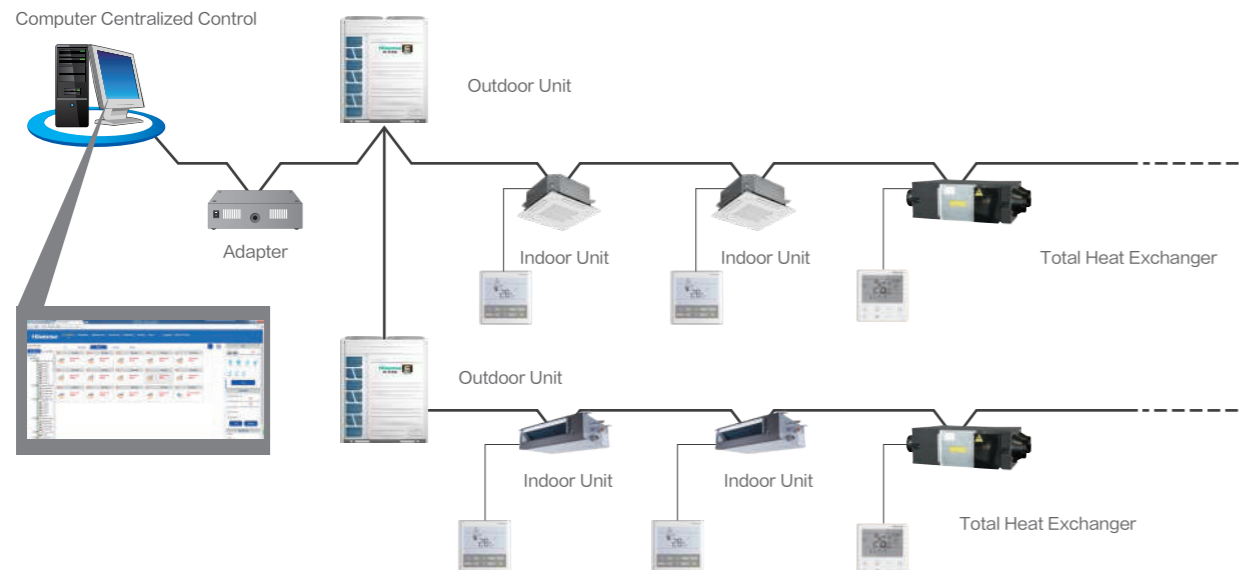

Heat Recovery Ventilator

HKF-15B2EC

Product Dimensions

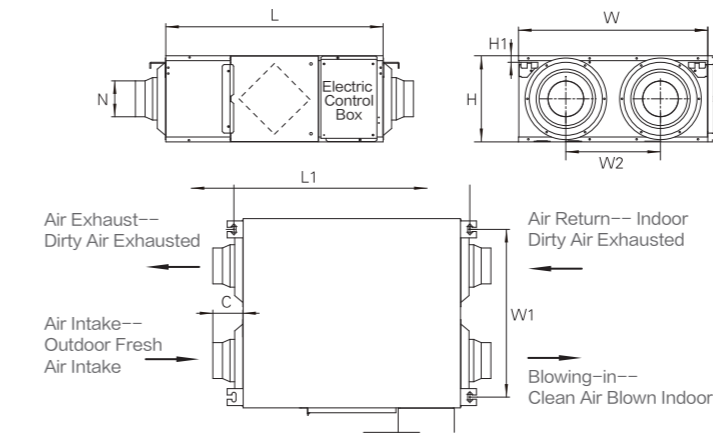

Model	L	L1	W	W1	W2	H	C	N	H1
HKF-15B2EC*	665	723	580	514	290	265	90	φ144	20

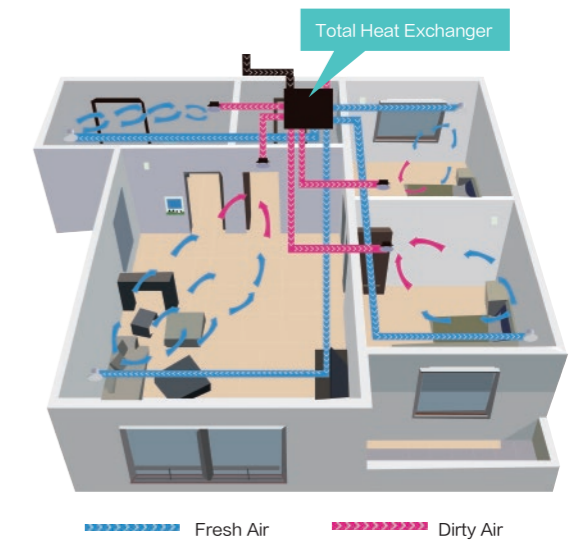

Technical Parameters

Model	Air Volume m ³ /h			Enthalpy Efficiency (Summer η ₁)			Enthalpy Efficiency (Winter η ₁)			External Static Pressure Pa			Power Supply	Input Current A			Input Power kW			Noise Level dB(A)			Weight kg
	High	Middle	Low	High	Middle	Low	High	Middle	Low	High	Middle	Low		High	Middle	Low	High	Middle	Low				
HKF-15B2EC*	150	150	110	58	58	60	65	65	69	85	70	65	220-240V/50HZ	0.38	0.36	0.31	2x0.041	2x0.038	2x0.029	30	29	28	25

* 220V/60Hz HKF-15B2E2

Product Feature

□ Compact Machine, Convenient Installation

The thickness of machine is not more than 270mm that can be easily installed in the narrow residential ceiling. The width of the machine whose volume is under 300 m³/h is less than 600mm, which is particularly suitable for very narrow spaces in the ceiling, and can save the space of installation and ceiling. It is more convenient for construction.

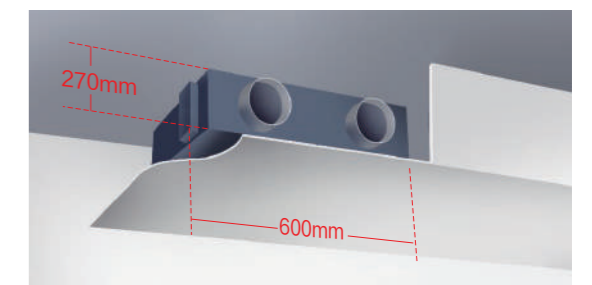

□ Adjustable Air Volume, Quiet Operation

The air volume can be adjusted at a range of high, medium, or low level, the lowest noise in low level is only 28 dB(A) (HKF-15B1(2)EC in low level), which reaches the lowest level in the industry.

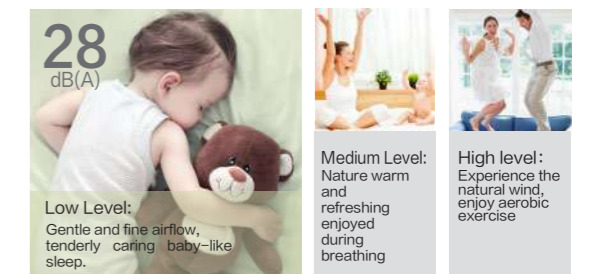

28 dB(A)

Low Level: Gentle and fine airflow, tenderly caring baby-like sleep.

Medium Level: Nature warm and refreshing enjoyed during breathing

High Level: Experience the natural wind, enjoy aerobic exercise

Heat Recovery Ventilator

HKF-25B2EC~HKF-100B2EC

Product Dimensions

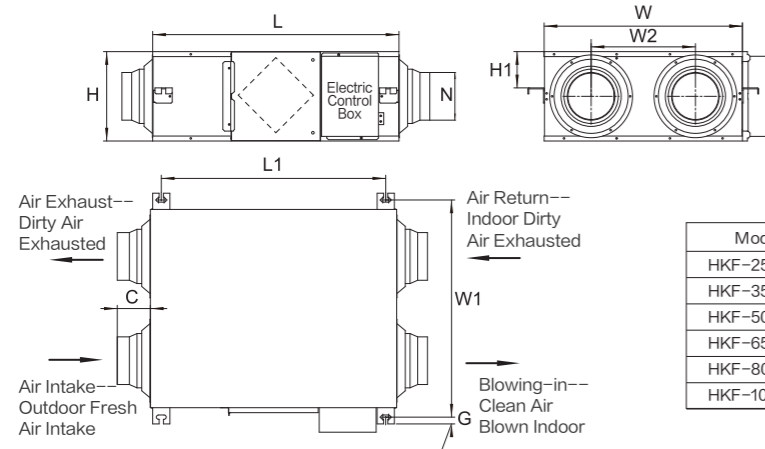

Model	L	L1	W	W1	W2	H	C	G	N	H1
HKF-25B2EC*	745	675	600	656	315	270	90	19	Φ144	110
HKF-35B2EC*	745	675	805	861	480	270	90	19	Φ144	110
HKF-50B2EC*	825	755	905	961	500	270	96	19	Φ194	110
HKF-65B2EC*	1115	1050	885	941	430	390	80	19	Φ242	175
HKF-80B2EC*	1115	1050	1135	1191	675	390	80	19	Φ242	175
HKF-100B2EC*	1115	1050	1135	1191	675	390	80	19	Φ242	175



Technical Parameters

Model	Air Volume m ³ /h			Enthalpy Efficiency (Summer) η ₁			Enthalpy Efficiency (Winter) η ₂			External Static Pressure Pa			Power Supply	Input Current A			Input Power kW			Noise Level dB(A)			Weight kg
	High	Middle	Low	High	Middle	Low	High	Middle	Low	High	Middle	Low		High	Middle	Low	High	Middle	Low	High	Middle	Low	
	HKF-25B2EC*	250	250	190	57	57	59	63	63	68	85	65		60	220-240V/50Hz	0.66	0.56	0.52	2×0.069	2×0.055	2×0.049	32	
HKF-35B2EC*	350	350	270	55	55	57	62	62	65	100	75	65		0.76	0.75	0.71	2×0.083	2×0.079	2×0.075	34	33	31	35
HKF-50B2EC*	500	500	400	56	56	58	63	63	65	130	110	100		1.82	1.71	1.52	2×0.189	2×0.157	2×0.124	39	38	36	40
HKF-65B2EC*	650	650	550	57	57	59	63	63	68	130	100	100		1.75	1.62	1.51	2×0.193	2×0.178	2×0.164	40	38	35	62
HKF-80B2EC*	800	800	650	58	58	59	66	66	68	130	100	90		1.98	1.88	1.75	2×0.211	2×0.196	2×0.18	42	40	37	72
HKF-100B2EC*	1000	1000	700	56	56	58	63	63	66	165	120	60		4.68	4.18	3.47	2×0.510	2×0.450	2×0.363	44	42	38	79

* 220V/60Hz HKF-25B2EC~HKF-100B2EC

HKF-150B2EE~HKF-200B2EE

Product Dimensions

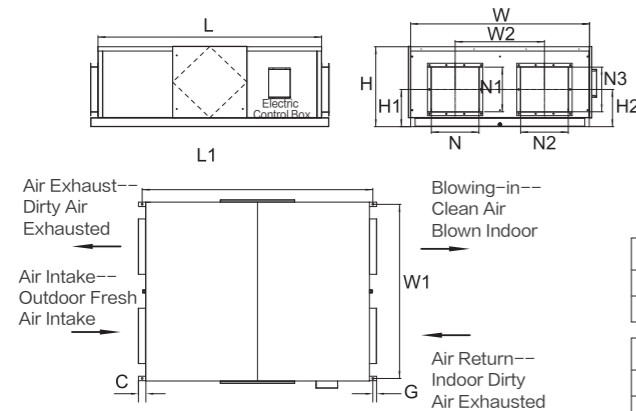

Model	L	L1	W	W1	W2	H	H1
HKF-150B2EE*	1500	1550	1200	1170	600	540	250
HKF-200B2EE*	1550	1600	1400	1370	700	540	250

Model	C	G	N	N1	N2	N3	H2
HKF-150B2EE*	50	25	320	300	320	300	250
HKF-200B2EE*	50	25	320	300	320	300	250

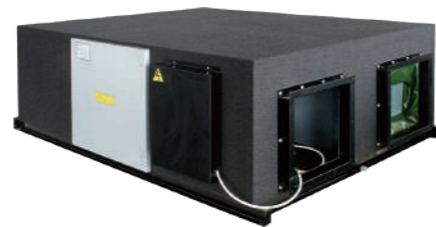

Technical Parameters

Model	Air Volume m ³ /h	Enthalpy Efficiency (Summer) η ₁	Enthalpy Efficiency (Winter) η ₂	External Static Pressure Pa	Power Supply	Input Current A	Input Power kW	Noise Level dB(A)	Weight kg
HKF-150B2EE*	1500	55	63	180	380-415V/50Hz	2.78	2×0.41	48	151
HKF-200B2EE*	2000	54	62	160		2.89	2×0.52	49	172

* AC3Φ220V/60Hz HKF-150B2EE HKF-200B2EE
AC3Φ380V/60Hz HKF-150B2EF HKF-200B2EF

Heat Recovery Ventilator

HKF-250B2EE~HKF-300B2EE

Product Dimensions

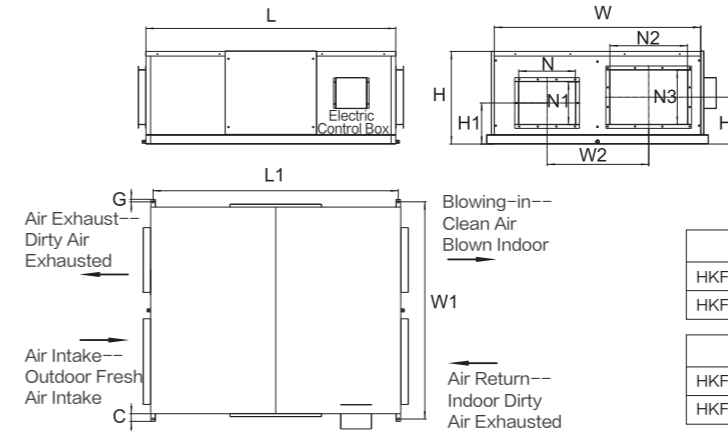

Model	L	L1	W	W1	W2	H	H1
HKF-250B2EE*	1610	1580	1330	1400	655	600	265
HKF-300B2EE*	1700	1670	1500	1570	750	640	272

Model	C	G	N	N1	N2	N3	H2
HKF-250B2EE*	50	15	365	275	500	350	300
HKF-300B2EE*	50	15	365	275	500	350	309



Technical Parameters

Model	Air Volume m ³ /h	Enthalpy Efficiency (Summer) η ₁	Enthalpy Efficiency (Winter) η ₂	External Static Pressure Pa	Power Supply	Input Current A	Input Power kW	Noise Level dB(A)	Weight kg
HKF-250B2EE*	2500	54	62	180	380-415V/50Hz	3.86	2×0.72	53	185
HKF-300B2EE*	3000	55	63	200		5.12	2×1.16	56	222

* AC3Φ220V/60Hz HKF-250B2EE HKF-300B2EE
AC3Φ380V/60Hz HKF-250B2EF HKF-300B2EF

HKL-400B2EE~HKL-500B2EE

Product Dimensions

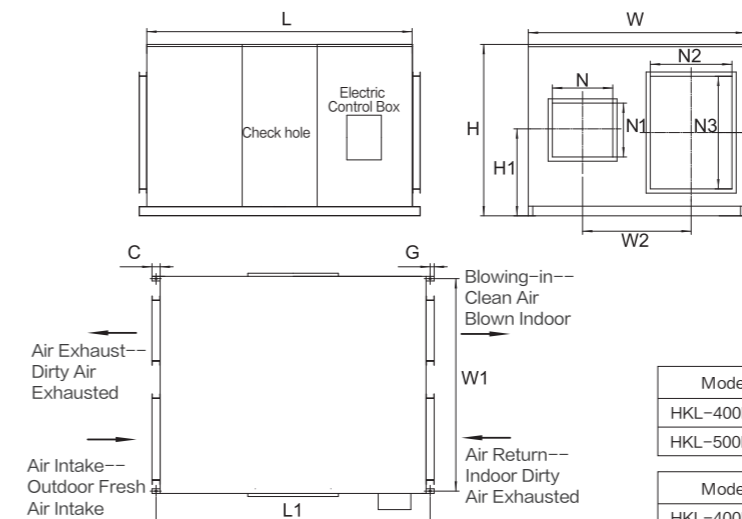

Model	L	L1	W	W1	W2	H	H1
HKL-400B2EE*	1625	1675	1330	1300	665	1050	490
HKL-500B2EE*	1625	1675	1330	1300	665	1050	490

Model	C	G	N	N1	N2	N3	H2
HKL-400B2EE*	50	25	370	330	500	690	475
HKL-500B2EE*	50	25	370	330	500	690	475

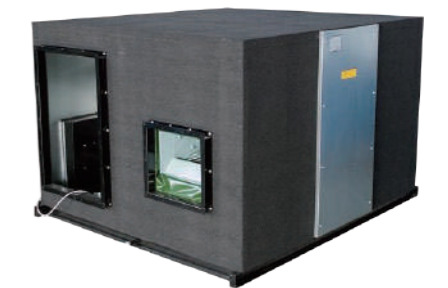

Technical Parameters

Model	Air Volume m ³ /h	Enthalpy Efficiency (Summer) η ₁	Enthalpy Efficiency (Winter) η ₂	External Static Pressure Pa	Power Supply	Input Current A	Input Power kW	Noise Level dB(A)	Weight kg
HKL-400B2EE*	4000	55	63	220	380-415V/50Hz	5.89	2×1.71	57	312
HKL-500B2EE*	5000	53	61	240		8.78	2×2.2	58	321

* AC3Φ220V/60Hz HKL-400B2EE HKL-500B2EE
AC3Φ380V/60Hz HKL-400B2EF HKL-500B2EF

AHU Connection Kit

AHU Connection Kit



The Hisense AHU-KIT can integrate external heat exchangers of Air-handling units (AHU) into a Hisense VRF system to be used for air conditioning, which can provide more flexible air conditioning solutions and save more cost in the building air conditioning renovation.

Main Functions

- ◆ ON/OFF Control
- ◆ Temperature Setting
- ◆ Capacity Demand
- ◆ Operation Mode

Selection and Limitation of Heat Exchanger of AHU

The Heat Exchanger of AHU(field-supplied)should be selected according to the following technical data and limitations. Lifetime of the outdoor unit, operation range or operation reliability may be influenced if these limitations are neglected.

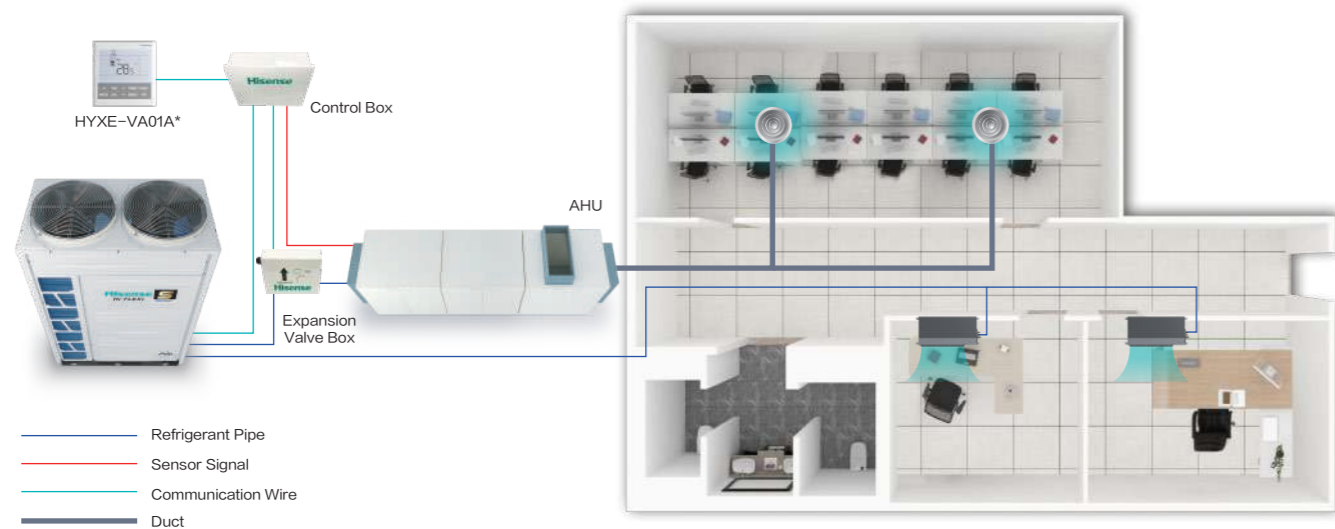

*The wired controller HYXE-VA01A is standard.

AHU Connection KIT		HZX-2.0 AEC	HZX-4.0 AEC	HZX-6.0 AEC	HZX-10.0AEC	HZX-20.0AEC						HZX-30.0AEC					
Model Power Supply		AC 1Φ,220-240V/50Hz/60Hz															
Nominal Capacity of AHU	HP	2	4	6	8	10	12	14	16	18	20	22	24	26	28	30	
Allowed Heat Exchanger Capacity (H/M/L)	Cooling	kW	4.0	7.1	11.2	16.0	20.0	28.0	33.5	40.0	45.0	50.0	56.0	61.5	69.0	73.0	80.0
		kW	5.0	9.0	14.0	20.0	25.0	30.0	35.0	43.0	48.0	52.0	58.0	65.0	71.0	76.0	82.0
		kW	5.6	11.2	16.0	22.4	28.0	33.5	40.0	45.0	50.0	56.0	61.5	69.0	73.0	80.0	85.0
	Heating	kW	4.5	8.0	12.5	17.9	22.4	31.5	37.5	45.0	50.0	56.0	63.0	69.0	77.5	82.5	90.0
		kW	5.6	10.0	16.0	22.4	28.0	33.5	40.0	47.5	53.0	60.0	66.0	75.0	79.0	86.0	92.0
		kW	7.1	12.5	18.0	25.0	31.5	37.5	45.0	50.0	56.0	63.0	69.0	77.5	82.5	90.0	95.0
Heat Exchanger Volume	Min	dm ³	0.57	1.03	1.92	2.92	3.89	4.76	5.85	6.79	7.57	8.47	9.04	9.50	10.39	11.39	12.36
	Max	dm ³	1.16	2.37	2.92	3.89	4.76	5.91	6.89	8	8.92	9.97	11.13	12.34	12.89	13.86	14.73
Equivalent Indoor Unit Capacity	HP	2	4	6	8	10	12	14	16	18	20	22	24	26	28	30	
Control Box Model		HZX-AEC/1															
Expansion Valve Box Model		HZX-2.0 AEC/2	HZX-4.0 AEC/2	HZX-6.0 AEC/2	HZX-10.0 AEC/2	HZX-20.0 AEC/2				HZX-20.0AEC/2 2set							

*Cooling and heating capacity data based on the following indoor and outdoor temperature conditions:

Operation Conditions		Cooling	Heating
Indoor Air Inlet Temperature	DB	27.0°C	20.0°C
	WB	19.0°C	-
Outdoor Air Inlet Temperature	DB	35.0°C	7.0°C
	WB	-	6.0°C

DB: Dry Bulb; WB: Wet Bulb; Pipe Length: 7.5m; Pipe Height: 0m

Controller

- HYXE-VA01A
- HYXE-J01H
- HYXM-VB01A
- HYXE-VC01
- HYXE-S01H
- HYE-VD01
- HYJM-S01H
- HYJ-J01H



Independent Controller

HYXE-VA01A 120mm × 120mm



Temperature Sensor

You can choose temperature sensor or default setting (always return air temperature) as standard to set temperature. The temperature sensor will be more precise to ensure customers' comfort.



Backlight

The backlight display, clearly visible during day and night.



Address Setting

Do not dial-up. You can set address to accurately find every IDUs.

- ◆ Adjust running light / keyclick
- ◆ Control air louvers independently
- ◆ 72-hour timer
- ◆ Multiple speed
- ◆ Max. 16 indoor units can be connected
- ◆ Self-cleaning

- ◆ Cooling/Heating/Dry/Fan/Auto
- ◆ Error code display
- ◆ Air filter cleaning reminding
- ◆ Built-in temperature sensor
- ◆ 0.5°C temperature setting
- ◆ Dehumidification

- ◆ Optional setting
- ◆ Check
- ◆ 3D-Airflow setting
- ◆ One touch test run
- ◆ Backlight control
- ◆ Swing louver

HYXE-J01H 120mm × 120mm

- ◆ Choose 10 different languages you love
- ◆ Adjust running light / keyclick
- ◆ Set humidity
- ◆ Control air louvers independently
- ◆ Dehumidification

- ◆ LED clear display
- ◆ Temperature sensor
- ◆ Connect with Hi-Motion
- ◆ Weekly timer/Holiday setting
- ◆ Address setting



Independent Controller

HYXM-VB01A 86mm × 90mm



Touchscreen

You interact with VB01 using your fingers to tap objects on the touchscreen instead of keyboard. 3.5 inches. It is convenient to operate with bigger screen showing.



Multilingual*

Note: there are two models.

12 different languages. Choose the language you love.



Auto-brightness

It can adjust the screen that is synchronous with running light for current light conditions. Dim the screen automatically to reduce light before you need to recharge air-conditioning.



Appearance

The appearance delivers the most accurate streamlined design in the industry. VB01 uses subtly hisense-designed materials that is precisely machined to create structural bands in the side. Aluminum alloy design adopts CNC technology to keep luster.



Intelligent

Match all kinds of hisense indoor units. If each air deflector can be controlled independently, the key will light. On the contrary, the key will dim and you can not tap.

- ◆ Check PCB fault by itself
- ◆ Modify the address of indoor units
- ◆ Restart after sudden power outage
- ◆ Control 6 indoor units
- ◆ Prevent children from touch by mistakes
- ◆ Set weekly timer
- ◆ Equip wireless receiver
- ◆ Dehumidification
- ◆ Room temperature display
- ◆ Self-cleaning

HYXE-VC01 86mm × 86mm

- ◆ Cooling/Heating/Auto
- ◆ Dehumidification
- ◆ Fan speed
- ◆ Operation monitoring
- ◆ 24-hour timer
- ◆ Main-sub control
- ◆ Check function
- ◆ Air filter cleaning reminding
- ◆ Error code history display
- ◆ Auto test run
- ◆ Indoor/Outdoor PCB checking
- ◆ Self diagnostic function
- ◆ Back light
- ◆ Built-in temperature sensor
- ◆ Wireless control available
- ◆ Individual louver control
- ◆ Breeze mode
- ◆ Health(AirPure)
- ◆ ECO(energy saving)
- ◆ Quiet
- ◆ Sleep
- ◆ Window contact design
- ◆ 3D-Air flow
- ◆ Self-cleaning



Independent Controller

HYXE-S01H 120mm×70mm



- ◆ Cooling/Heating/Dry/Fan/Auto
- ◆ 3 or 6 speed control
- ◆ Touch buttons
- ◆ Optional setting
- ◆ Quiet
- ◆ Check
- ◆ Test run
- ◆ Dehumidification
- ◆ Timer
- ◆ Air filter cleaning reminding
- ◆ Icon function display
- ◆ Fan speed/Swing louver

HYE-VD01 178.6mm×47.8mm



- ◆ Cooling/Heating/Auto
- ◆ Fan speed
- ◆ Operation monitoring
- ◆ 24-hour timer
- ◆ Auto test run
- ◆ Self diagnostic function
- ◆ Back light
- ◆ Built-in temperature sensor
- ◆ Individual louver control
- ◆ Breeze mode
- ◆ Health(AirPure)
- ◆ ECO(energy saving)
- ◆ Quiet
- ◆ Sleep
- ◆ 3D-Air flow
- ◆ Self-cleaning

Receiver Kit for Wireless Control (Optional)

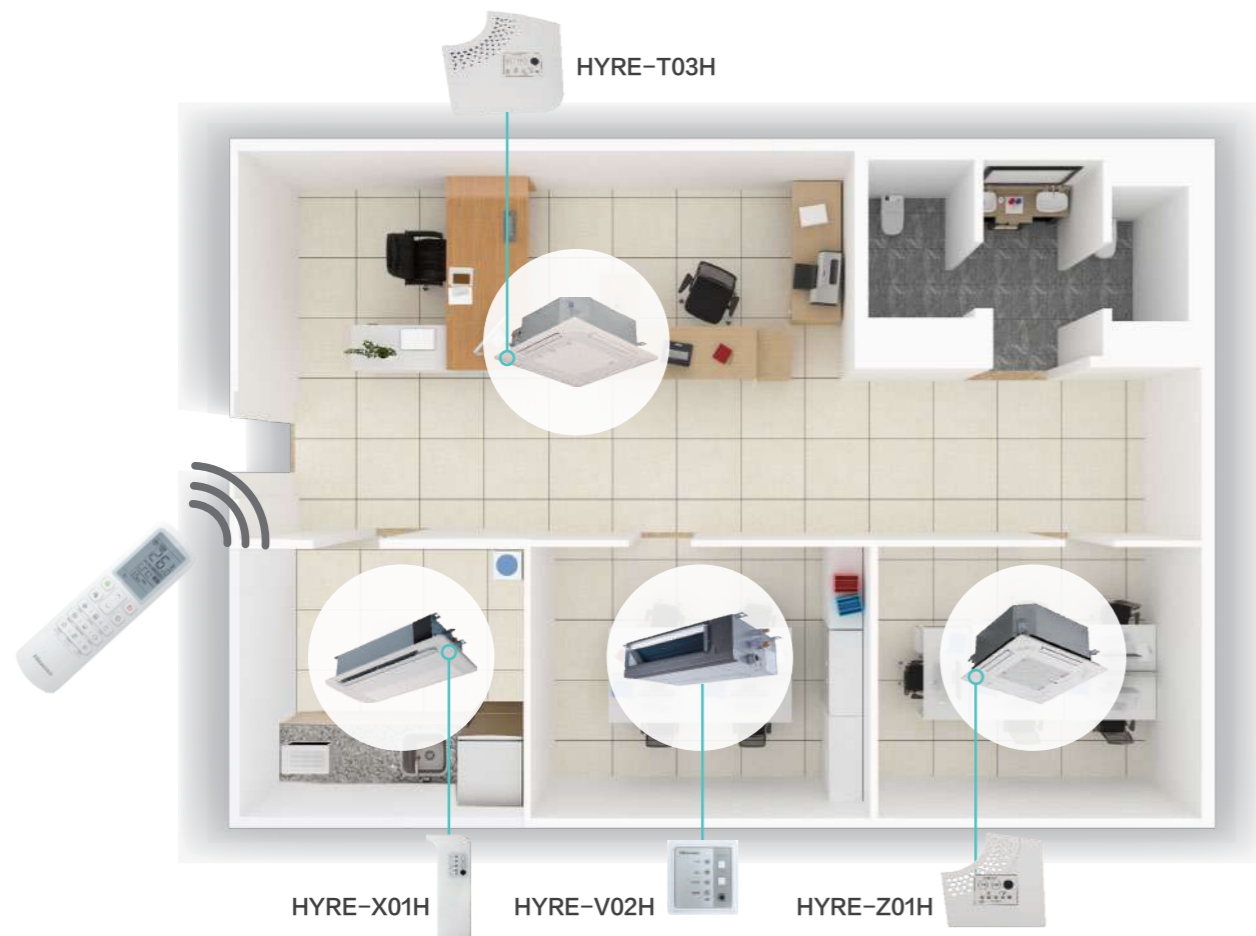

Centralized Controller

HYJM-S01H 148mm×220mm



Multilingual

8 different languages. Choose the language you love and click "OK".

中文	English	Русский	Español
Türkçe	Deutsch	Italiano	Nederlands

Group Centralized Control

Register the searched IDUs to the group of the central controller. Max.160 indoor units (64 groups) can be connected. HYJM-S01H can show all running of each group.

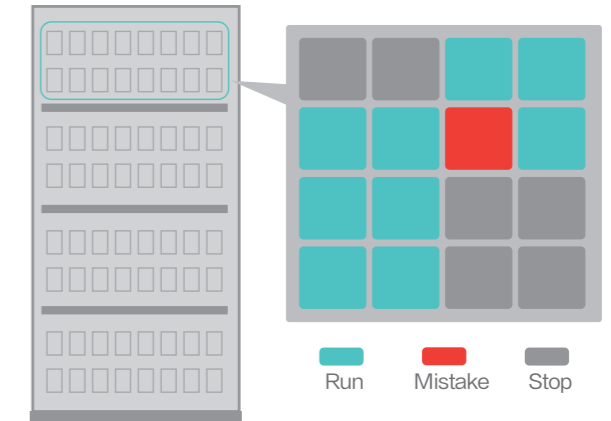

External Input/Output Setting

External Input Setting

When there is a fire, you can control all IDUs stopping with only one press in the emergency.



External Output Setting

When the system steps into the full load operation, external safety light will remind you.



Temperature Limitation

You can set higher limit of heating and lower limit of cooling to save energy.

Lock Wired Controller

Decide wired controller running mode and operation limitation.







Holiday Setting







Turn on or off the air-conditioning after presetting depend on your different demand. Light-touch key to choose holiday mode with only one press. You can choose to control all IDUs or only one.

HYJ-J01H 120mm×120mm

- ◆ Group control(ON/OFF)
- ◆ Indoor unit power OFF reminder
- ◆ External input setting
- ◆ Indoor units auto login in
- ◆ Error reminder
- ◆ Max. 128 indoor units (16 Group) can be connected



Type		Wired Controller					Wireless Controller
Model		HYXE-VA01A	HYXE-J01H	HYXM-VB01A	HYXE-VC01	HYXE-S01H	HYE-VD01
Picture							
Suit for Indoor Unit	4-Way Cassette	○	○	○	○	○	○
	Mini 4-Way Cassette	○	○	○	○	×	○
	AC/DC Low Height	○	○	○	○	○	○
	Ceiling Duct	○	○	○	○	○	○
	1-Way Cassette	○	○	○	○	×	○
	2-Way Cassette	○	○	○	○	×	○
	Console	○	○	○	○	○	✓
	Wall Mounted	○	○	○	○	○	✓
	Ceiling & Floor	○	○	○	○	○	✓
	Floor Concealed	○	○	○	○	×	○
	All Fresh Air Indoor Unit	○	○	○	○	○	○
	Heat Recovery Ventilation	○	○	○	✓	○	×
	3D-Airflow Panel	○	○	○	○	×	○
AHU KIT	✓	○	○	○	×	×	

Type		Receiver Kit				Centralized Controller	ON/OFF
Model		HYRE-V02H	HYRE-T03H	HYRE-Z01H	HYRE-X01H	HYJM-S01H	HYJ-J01H
Picture							
Suit for Indoor Unit	4-Way Cassette	×	○	×	×	○	○
	Mini 4-Way Cassette	×	×	○	×	○	○
	AC/DC Low Height	○	×	×	×	○	○
	Ceiling Duct	○	×	×	×	○	○
	1-Way Cassette	×	×	×	○	○	○
	2-Way Cassette	○	×	×	×	○	○
	Console	○	×	×	×	○	○
	Wall Mounted	○	×	×	×	○	○
	Ceiling & Floor	○	×	×	×	○	○
	Floor Concealed	○	×	×	×	○	○
	All Fresh Air Indoor Unit	○	×	×	×	○	○
	Heat Recovery Ventilation	×	×	×	×	○	○
	3D-Airflow Panel	○	×	×	×	○	○
AHU KIT	×	×	×	×	○	○	

Remarks: ✓ Standard ○ Optional × Incompatible

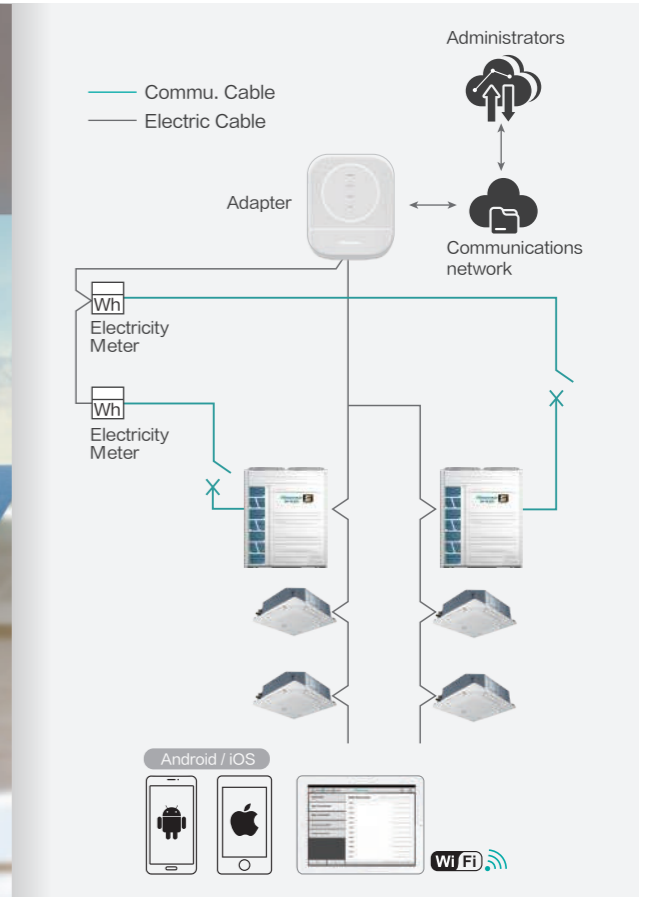
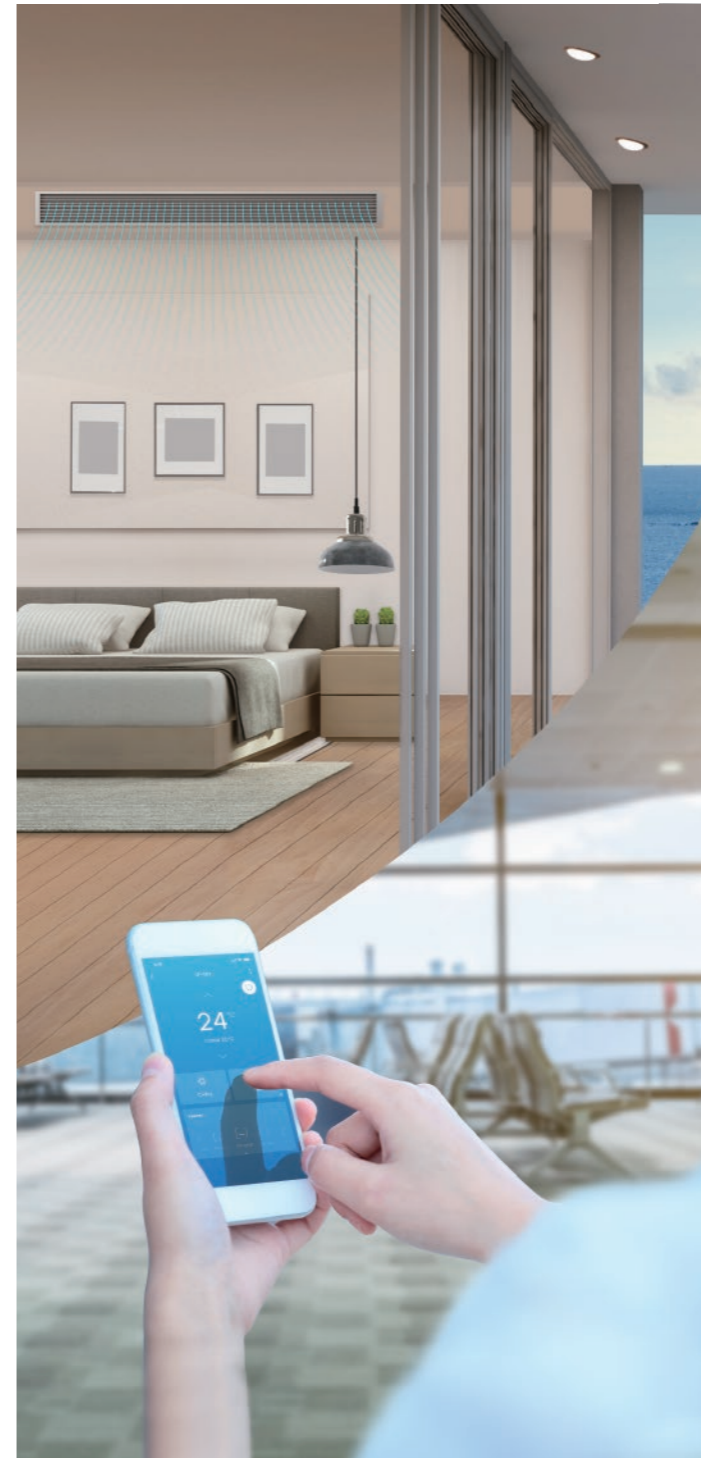

Features

- Remote control
- On/off, mode, temperature, fan speed, louver setting
- 7x24 Schedule setting
- Energy management
- Customized scenes setting
- 2 permission levels
- Supporting online repair report
- Up to 64 IDUs and 64 ODU can be connected to one Hi-Mit II adapter
- 3 Hi-Mit II adapters are available in one communication bus system
- One user account of APP can control 32 adapters, up to 2048 IDUs

Specifications

Model	Power Supply	Max. Current	Power Input	Dimension	Net Weight
HCCS-H64H2C1M	DC 12V	1A	2.4W	91x117x31mm	0.14kg

Hi-Dom III Air Conditioning Management System

Centralized Control

Hi-Dom III air conditioning management system adopts communication bus connection; Air conditioning indoor units are connected to the computer through network converter; The system is all controlled automatically by a computer with powerful functions and simple operation. One single computer control system can manage 5120 indoor units.

- ◆ Multilevel user management
- ◆ AC control(ON-OFF,Mode,Temp,Air Flow)
- ◆ AC locked control(running forbidden control, the max. and min. temp and cooling/heating locked.)
- ◆ Running according to timer
- ◆ Malfunction history check
- ◆ Supporting for external I/O
- ◆ Running record display
- ◆ One Hi-Dom III controls 160 indoor units
- ◆ Electricity consumption allocation
- ◆ 2D Navigation
- ◆ Supporting for external I/O
- ◆ Data synchronize
- ◆ Max.5120 indoor units can be controlled

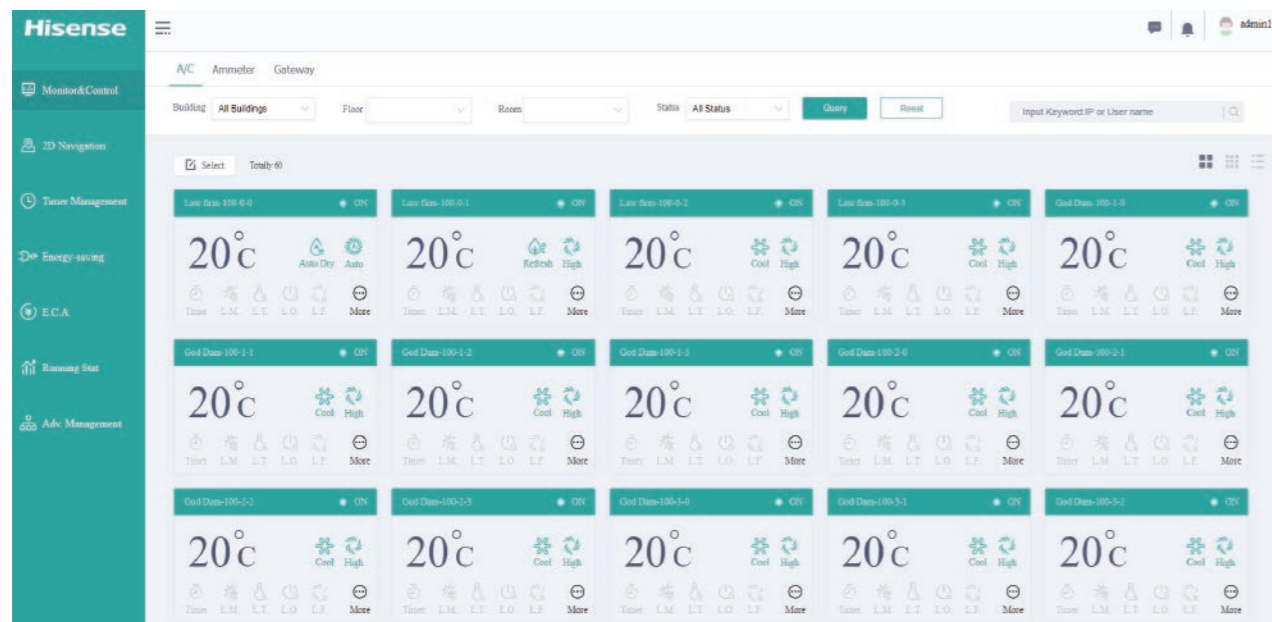

All the indoor units and outdoor units are connected with one adapter comprise one communication BUS system.
 Max. 160 indoor units can be connected to an adapter.
 Max. 32 adapters can be controlled by one computer.
 Max. 5120 indoor units are under control.

Electric Charge Allocation

In accordance with the operation time and capacity output of indoor and outdoor units, the electric charge allocation software allocates the total power consumption to each indoor unit.

Hi-Dom III Air Conditioning Management System

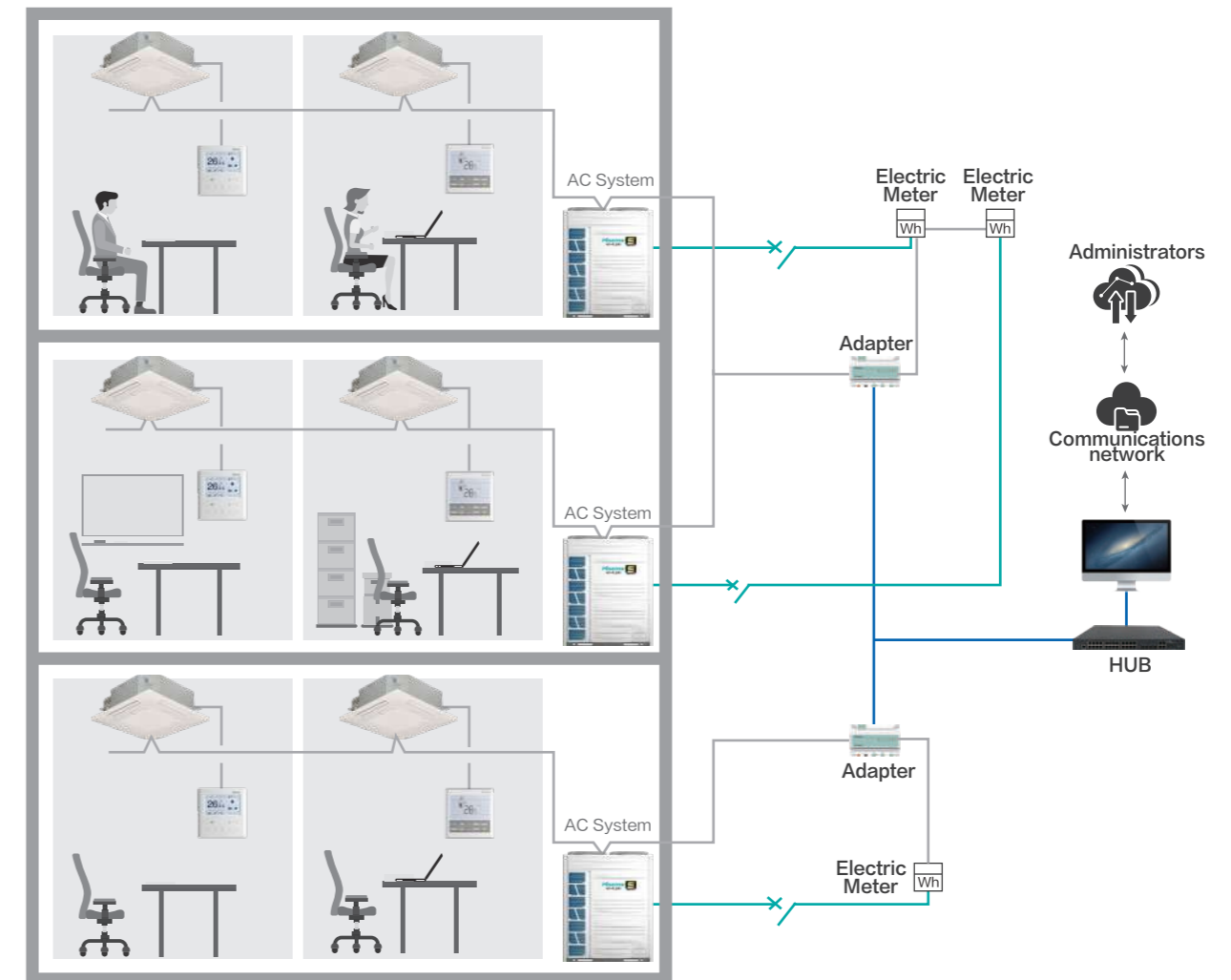

Note: Due to different laws and regulations in different regions, Hisense electrical charge calculation software need to customize processing in project according to the users' requirement.
 Only support electric meter—— iEM3150 or iEM3250, which is supplied by Schneider Electric.

Hi-Dom III System Specifications

	Model	Power Supply	Dimension(LxWxD)	Note
Adapter	HCCS-H160H2C1YM	12V	180x115.4x64.5mm	With electric charging function
	HCCS-H160H2C1NM	12V	180x115.4x64.5mm	Without electric charging function

INTELLIGENT SERVICE TOOL

IMPROVE YOUR SERVICE



Hi-Checker is a plug and play service tool, with which service engineers can access the system and monitor operation status or data, very convenient for system communication and maintenance. Besides, it features cloud-based management, easy to access operation status remotely.



Small and Portable Body



Remote Access



Black Box Function



Powerful Chats



OTC Update

EASY TO USE

- ◆ Compact size which allows high portability and space saving.
- ◆ Capable to slot in a 32G memory card for data collection and storage. Also the memory card and card reader are standard with Hi-Checker.
- ◆ Multiple choices of power supply types. It can be powered by the standard adapter (DC 5V), computer or power bank.
- ◆ Support OTA update, ensuring the software is always up to date.



EASY TO ACCESS

4 ways to access the operation data

- ◆ Conventional connection type. The simplest and reliable way by just connecting the Hi-Checker to your computer directly through USB.
- ◆ Internet connection type. Be connected to a stable Wi-Fi signal to achieve operation data and status monitoring anytime and anywhere.
- ◆ Hotspot connection type. Be connected to a temporary hotspot signal from the smartphone, allowing the Hi-Checker to remotely monitor the operation data when there is no stable Wi-Fi signal on site.
- ◆ SD card storage type. Hi-Checker equipped with SD card can be connected to the air conditioning system all the time, so that all the operation data can be stored in the card for later analysis.

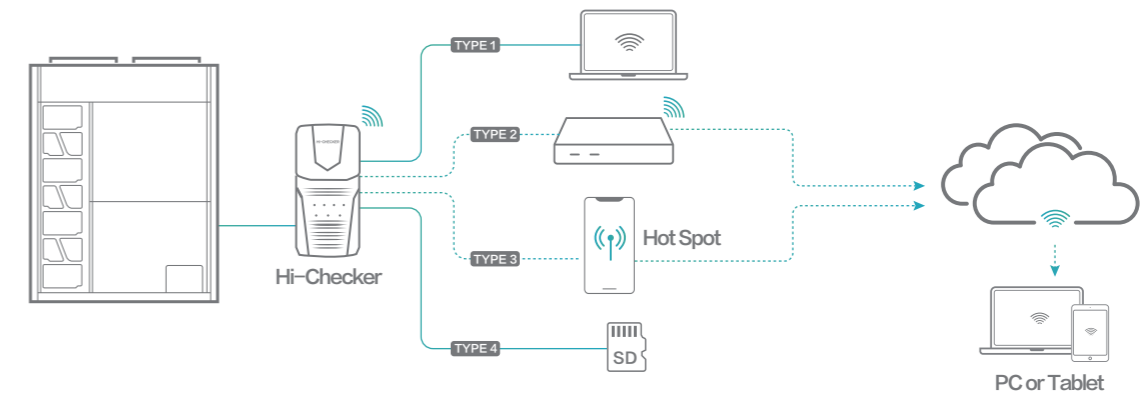

EASY TO UNDERSTAND

- ◆ Powerful and detailed chart analysis on the operation data, allowing users to determine the system condition easily. Together with the smart system diagram, it is interesting and easier for maintenance.
- ◆ User friendly. Users can export the professional report either in .csv or .pdf format.

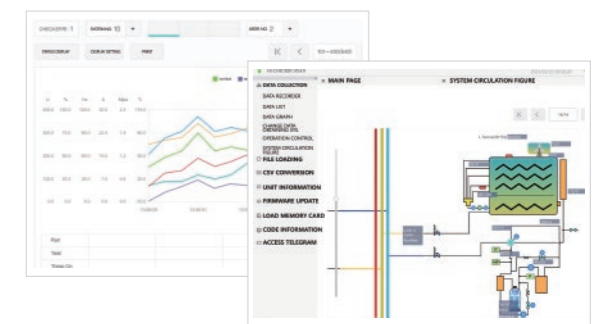

Specifications

Size(LxWxH)mm	Net Weight (g)	Power Supply	Connectable IDUs
138x68x28	130	5V ---500mA	160

Building Management System

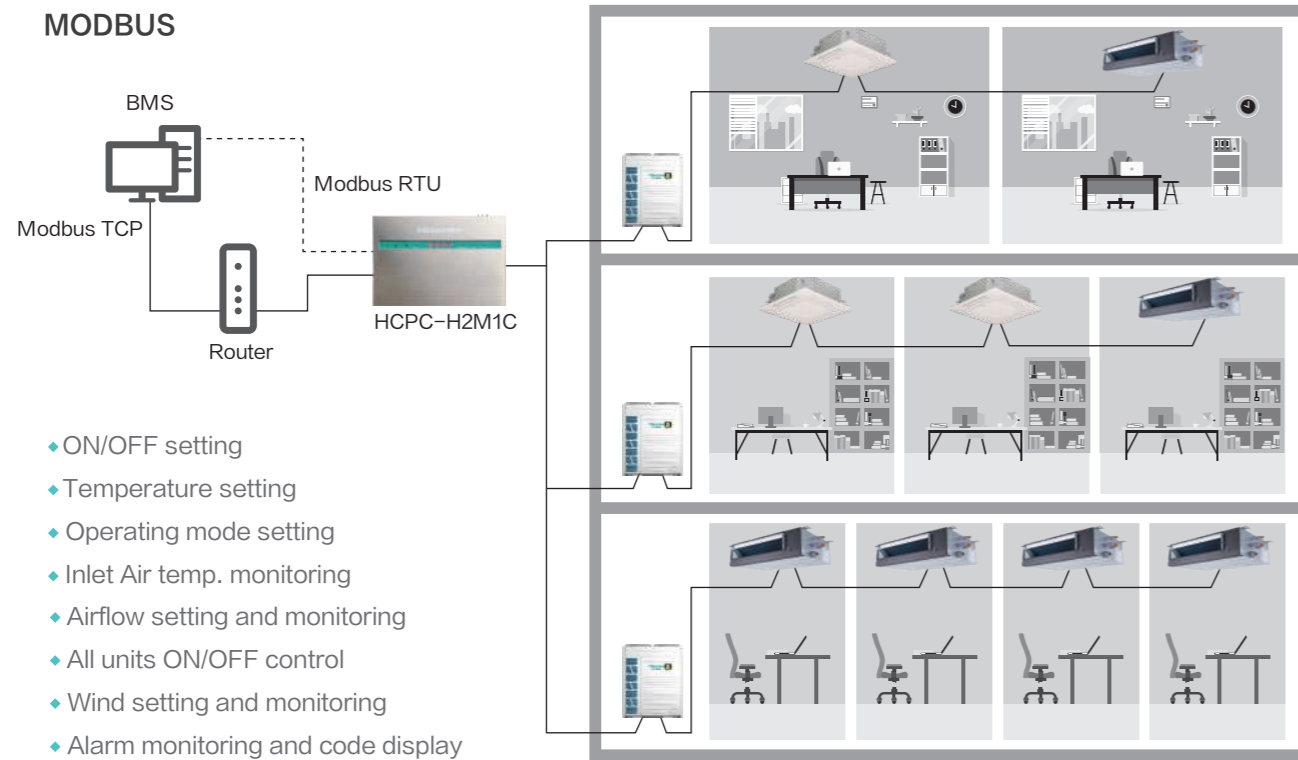

BACnet

Intesis Box BACnet server makes available the Hisense VRF system through independent BACnet objects. It can be applied to third party intelligent control system with BACnet/IP or BACnet MSTP protocol.

Main Functions

- ◆ Central Control of All Indoor Units
- ◆ Indoor Unit Data Monitoring
- ◆ Heat / Dry / Fan / Cool / Auto Mode Control
- ◆ Vane Position Swing Control
- ◆ Function Prohibition of Wired Controller

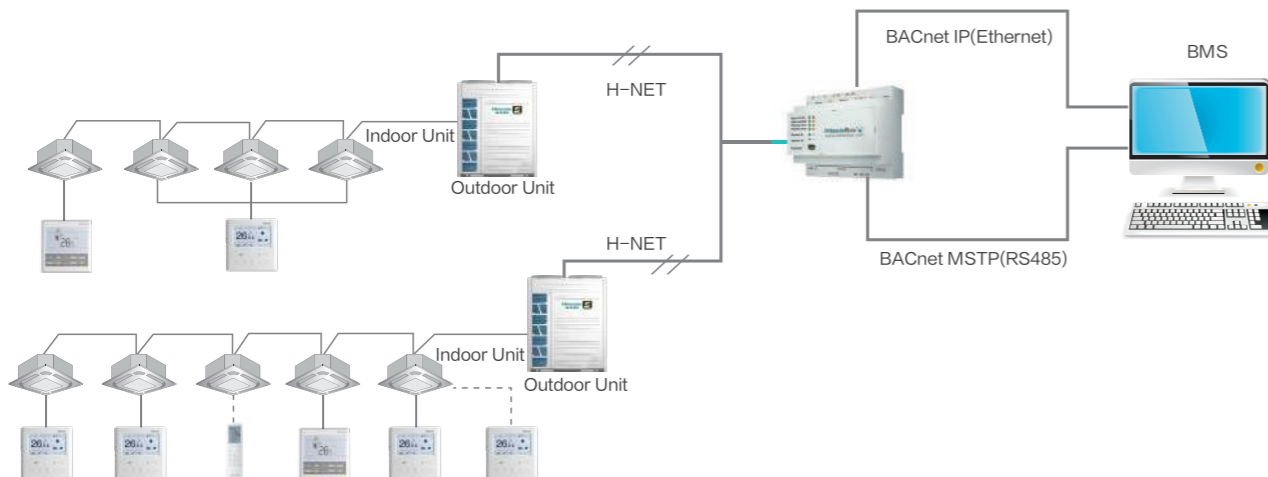

Building Management System

KNX

Intesis Box KNX gateways for air conditioners offers the largest range of gateways in the market for AC system integrations. These solutions offer a huge compatibility to all the KNX manufactures, and can be controlled by a simple KNX thermostat, advanced KNX touch panels or APPs.

Main Functions

- ◆ Function Prohibition of Controller
- ◆ Operation Control(ON/OFF, Temp. Setting, Mode Control etc.)
- ◆ Indoor Unit Data Monitoring
- ◆ Alarm Monitoring and Code Display
- ◆ Bidirectional Communication and Simultaneous Control from KNX and AC's Controller

One to One

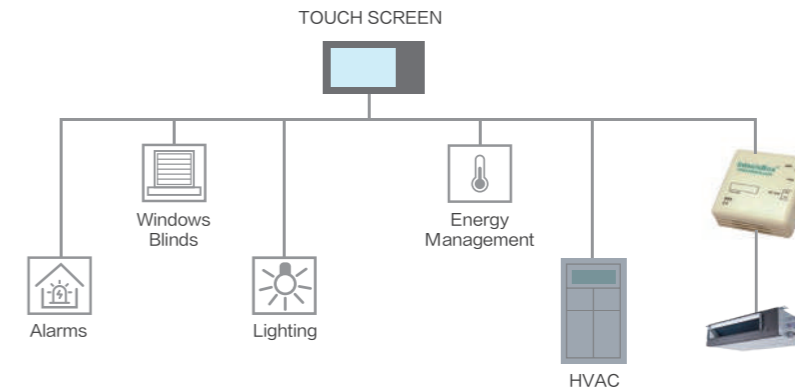

More to One

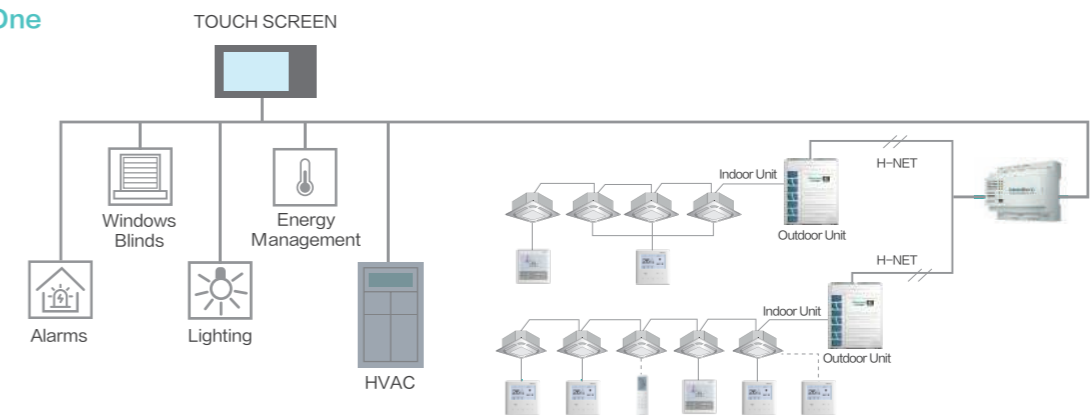

Protocol	Model	H(mm)	W(mm)	D(mm)	Max. Number of Connectable Indoors Units
KNX	HS-RC-KNX-1i	70	70	28	1
KNX	HS-AC-KNX-16	90	88	56	16
KNX	HS-AC-KNX-64	90	88	56	64
BACnet	HS-AC-BAC-16	90	88	56	16
BACnet	HS-AC-BAC-64	90	88	56	64
Modbus	HCPC-H2M1C	50	220	140	64

Accessory

Hi-Motion

Model	Applicable Models	Picture
HCM-S01E	All indoor unit except 4-way cassette type and mini 4-way cassette type	

Fresh Air Duct Adapter

Model	Applicable Models	Picture
HFL-56CSA	4-Way cassette type and mini 4-way cassette type	

Motion Sensor

Model	Applicable Models	Picture
HPS-MACN	Mini 4-way cassette type	
HCM-01E	4-Way cassette type	

Humidity Sensor

Model	Applicable Models	Picture
HCHR-S01E	4-Way cassette type, Console, Ceiling Ducted Type, Wall Mounted Type	

Filter

Filter model	Filter Dimension	Frame Dimension
HF-224L-FE	910 × 432.5mm	1055 × 463mm
HF-280L-FE	1100 × 432.5mm	1245 × 463mm

Note: For Low/High Ceiling Ducted Type AVD-76/96 only

Accessory

Drain Pump

Model	Applicable Models	Power Supply
HPS-F133E	AVD-07-24HCFCH	220-240V/50Hz
	AVD-07-24HCFCL	
HPS-F363E	AVD-27-54HCFCH	
	AVD-27-54HCFCL	
HPS-F134E	AVD-07-24H3FCH	208-230V/60Hz
HPS-F364E	AVD-27-54H3FCH	

Note: For Low/High Ceiling Ducted Type only.

Voltage Protector

Model	Power Supply	Dimension (H × W × D)	Picture
HOPT-EOUPA01	AC 3Φ, 380V~415V/50Hz	295 × 222 × 103mm	

3D Air-flow Panel

Panel Model	Applicable Models	Outer Dimensions (H × W × D)	Interface Dimension (H × W)
HP-CB-NA	For ceiling ducted type (DC/ AC low- height) 0.5-1.3HP	180 × 740 × 70mm	530 × 130mm
HP-DB-NA	For ceiling ducted type (DC/ AC low- height) 0.8-1.5HP	180 × 950 × 70mm	750 × 130mm
HP-EB-NA	For ceiling ducted type (DC/ AC low- height) 1.8-2.5HP	180 × 1220 × 70mm	1020 × 130mm

AirPure Kit

Model	Power Supply	Applicable Indoor Units	Picture
HJK-ELZA	AC 1Φ, 220V~240V 50/60Hz	4-Way Cassette Type, Mini 4-Way Cassette Type	
HJK-ELZB	AC 1Φ, 220V~240V 50/60Hz	Ceiling Ducted, Console	